

THE $RO(G)$ -GRADED SERRE SPECTRAL SEQUENCE

by

WILLIAM C. KRONHOLM

A DISSERTATION

Presented to the Department of Mathematics
and the Graduate School of the University of Oregon
in partial fulfillment of the requirements
for the degree of
Doctor of Philosophy

June 2008

“The $RO(G)$ -graded Serre Spectral Sequence” a dissertation prepared by William C. Kronholm in partial fulfillment of the requirements for the Doctor of Philosophy degree in the Department of Mathematics. This dissertation has been approved and accepted by:

Dr. Daniel Dugger, Chair of the Examining Committee

Date

Committee in charge: Dr. Daniel Dugger, Chair
 Dr. Alexander Kleshchev
 Dr. Hal Sadofsky
 Dr. Dev Sinha
 Dr. Mia Tuan

Accepted by:

Dean of the Graduate School

CURRICULUM VITAE

NAME OF AUTHOR: William C. Kronholm

PLACE OF BIRTH: Hartford, CT

DATE OF BIRTH: 06 December 1980

GRADUATE AND UNDERGRADUATE SCHOOLS ATTENDED:

University of Oregon, Eugene, OR
Rochester Institute of Technology, Rochester, NY

DEGREES AWARDED:

Doctor of Philosophy, University of Oregon, 2008
Master of Science, University of Oregon, 2008
Bachelor of Science, Rochester Institute of Technology, 2002

AREAS OF SPECIAL INTEREST:

Algebraic Topology, K-Theory, Equivariant Topology

PROFESSIONAL EXPERIENCE:

Graduate Teaching Fellow, University of Oregon, 2002-2008

GRANTS, AWARDS AND HONORS:

Distinguished Graduate Teaching Award, University of Oregon
Department of Mathematics, 2007

ACKNOWLEDGMENTS

I am grateful to Dan for his insight. His gift for making the wielding of the most abstract of notions seem like walking in the park is truly unique. Conversations with him have always been enlightening, and I hope to have many more as time goes on.

I am grateful to Chad for always being willing to have ideas bounced off of him.

I am grateful to Brandalee for keeping the ball rolling in the office.

I am grateful to all of my friends for their support.

I am grateful to my family for their love and patience these past six years while the width of the continent has separated us.

Most of all, I am grateful to Carly. This journey would not have been nearly as special without you.

To Carly, my love.

TABLE OF CONTENTS

Chapter	Page
I. INTRODUCTION	1
II. PRELIMINARIES	6
III. CONSTRUCTION OF THE SPECTRAL SEQUENCE	10
IV. HOMOTOPICAL CONSIDERATIONS	14
V. COHOMOLOGY OF PROJECTIVE BUNDLES	17
VI. $\text{REP}(G)$ -COMPLEXES	21
VII. COHOMOLOGY OF REAL PROJECTIVE SPACES	33
VIII. GRASSMANNIANS	42
IX. EQUIVARIANT ADAMS-HILTON CONSTRUCTION	55
X. EQUIVARIANT LERAY-HIRSCH THEOREM	63
XI. ON CHARACTERISTIC CLASSES	67

Chapter	Page
REFERENCES	71

LIST OF FIGURES

Figure	Page
I.1	The $r = 1$ spectral sequence for $id: X \rightarrow X$ 3
II.1	$H^{*,*}(pt; \mathbb{Z}/2)$ 9
VI.1	The E_1 page of the cellular spectral sequence attaching a single (p, q) -cell to B 23
VI.2	The nonzero portion of the same spectral sequence, after a change of basis. 24
VI.3	The $E_2 = E_\infty$ page of the above spectral sequence. 25
VI.4	An example where the nonzero differential hits the ‘tip’ of the bottom cone. 26
VI.5	The $E_2 = E_\infty$ page of the above spectral sequence. 27
VI.6	The E_1 page of the cellular spectral sequence with a single nonzero differential hitting the bottom cone of an attached (p, q) -cell. 29
VI.7	The $E_2 = E_\infty$ page of the cellular spectral sequence with a single nonzero differential hitting the bottom cone of an attached (p, q) -cell. 29
VI.8	The spectral sequence of a filtration for attaching a single (p, q) -cell to a space with free cohomology. 31
VI.9	The nonzero portion of the above spectral sequence, after a change of basis. 32
VII.1	The E_1 page of the cellular spectral sequence for $\mathbb{R}P_{tw}^n$ for n odd. 35
VII.2	The E_1 page of the cellular spectral sequence for $\mathbb{R}P_{tw}^n$ for n even. 36
VII.3	The E_1 page of the cellular spectral sequence for $\mathbb{R}P_{tw}^n$ for n even using flag symbol $(1, 2, \dots, a - 1, n + 1)$ 36
VIII.1	The E_1 term of the spectral sequence of the filtration of $G_2(\mathbb{R}^{4,1})$ with $\varphi_1 = (4)$ 45
VIII.2	The E_1 term of the spectral sequence of the filtration of $G_2(\mathbb{R}^{4,1})$ with $\varphi_2 = (3)$ 46
VIII.3	$H^{*,*}(G_2(\mathbb{R}^{5,1}))$ 47
VIII.4	The E_1 page of the cellular spectral sequence for $G_2(\mathbb{R}^{4,2})$ using $\varphi_1 = (2, 3)$ 48

Figure		Page
VIII.5	The E_1 page of the cellular spectral sequence for $G_2(\mathbb{R}^{4,2})$ using $\varphi_2 = (2, 4)$	49
VIII.6	The E_1 page of the cellular spectral sequence for $G_2(\mathbb{R}^{4,2})$ using $\varphi_3 = (3, 4)$	49
VIII.7	$H^{*,*}(G_2(\mathbb{R}^{4,2}))$	50
VIII.8	$H^{*,*}(G_2(\mathbb{R}^{4,2}))$ with free generators shown.	51
VIII.9	The cellular spectral sequence for $G_2(\mathbb{R}^{5,1})$ using $\varphi = 3$	53
VIII.10	$H^{*,*}(G_2(\mathbb{R}^{6,1}))$	54
IX.1	The E_1 page of the cellular spectral sequence for $\Omega S^{4,2}$	60
IX.2	The $r = 2$ spectral sequence for $\Omega S^{4,2} \rightarrow PS^{4,2} \rightarrow S^{4,2}$	61
IX.3	The $r = 4$ spectral sequence for $\Omega S^{4,2} \rightarrow PS^{4,2} \rightarrow S^{4,2}$	62

CHAPTER I

INTRODUCTION

In [2], Bredon created equivariant homology and cohomology theories of G -spaces, now called Bredon homology and Bredon cohomology, which yield the usual singular homology and cohomology theories when the group acting is taken to be the trivial group. In [11], a cohomology theory for G -spaces is constructed that is graded on $RO(G)$, the Grothendieck ring of virtual representation of G . This $RO(G)$ -graded theory extends Bredon cohomology in the sense that $H^{\underline{n}}(X) = H_{Br}^n(X)$ when \underline{n} is the trivial n -dimensional representation of G .

Many of the usual tools for computing cohomology have their counterparts in the $RO(G)$ -graded setting. These include Mayer-Vietoris sequences, Künneth theorem, suspension isomorphisms, etc. Missing from the $RO(G)$ computational tool box was an equivariant version of the Serre spectral sequence associated to a fibration $F \rightarrow E \rightarrow B$. Also, perhaps partially because of a lack of this spectral sequence, the theory of equivariant characteristic classes has not yet been developed.

The main result of this paper is to extend the spectral sequence of a G -fibration given in [15] from Bredon cohomology to the $RO(G)$ -graded theory with special attention to the case $G = \mathbb{Z}/2$. A p -dimensional real $\mathbb{Z}/2$ -representation V decomposes as $V = (\mathbb{R}^{1,0})^{p-q} \oplus (\mathbb{R}^{1,1})^q = \mathbb{R}^{p,q}$ where $\mathbb{R}^{1,0}$ is

the trivial representation and $\mathbb{R}^{1,1}$ is the nontrivial 1-dimensional representation. Thus the $RO(\mathbb{Z}/2)$ -graded theory is a bigraded theory, one grading measuring dimension and the other measuring the number of “twists”. In this case, we write $H^V(X; M) = H^{p,q}(X; M)$ for a Mackey functor M . Here is the spectral sequence:

Theorem. If $f: E \rightarrow X$ is a fibration of $\mathbb{Z}/2$ spaces, then for every $r \in \mathbb{Z}$ and every Mackey functor M there is a natural spectral sequence with

$$E_2^{p,q} = H^{p,0}(X; \mathcal{H}^{q,r}(f; M)) \Rightarrow H^{p+q,r}(E; M).$$

This is a spectral sequence that takes as inputs the Bredon cohomology of the base space with coefficients in the local coefficient system $\mathcal{H}^{q,r}(f; M)$ and converges to the $RO(\mathbb{Z}/2)$ -graded cohomology of the total space.

This is really a family of spectral sequences, one for each integer r . If the Mackey functor M is a ring Mackey functor, then this family of spectral sequences is equipped with a tri-graded multiplication. If $a \in H^{p,0}(X; \mathcal{H}^{q,r}(f; M))$ and $b \in H^{p',0}(X; \mathcal{H}^{q',r'}(f; M))$, then $a \cdot b \in H^{p+p',0}(X; \mathcal{H}^{q+q',r+r'}(f; M))$. There is also an action of $H^{*,*}(pt; M)$ so that if $\alpha \in H^{q',r'}(pt; M)$ and $a \in H^{p,0}(X; \mathcal{H}^{q,r}(f; M))$, then $\alpha \cdot a \in H^{p,0}(X; \mathcal{H}^{q+q',r+r'}(f; M))$.

Under certain connectivity assumptions on the base space, the local coefficients $\mathcal{H}^{q,r}(f; M)$ are constant, and the spectral sequence becomes the following. This result is restated and proved as Theorem III.1.

Theorem. If X is equivariantly 1-connected and $f: E \rightarrow X$ is a fibration of $\mathbb{Z}/2$ spaces with fiber F , then for every $r \in \mathbb{Z}$ and every Mackey functor M there is a spectral sequence with

$$E_2^{p,q} = H^{p,0}(X; \underline{H}^{q,r}(F; M)) \Rightarrow H^{p+q,r}(E; M).$$

The coefficient systems $\mathcal{H}^{q,r}(f; M)$ and $\underline{H}^{q,r}(F; M)$ that appear in the spectral sequence are explicitly defined in the next section. They are the equivariant versions of the usual local coefficient systems that arise in the Serre spectral sequence.

This spectral sequence is rich with information about the fibration involved, even in the case of the trivial fibration $id: X \rightarrow X$. In this case, the E_2 page takes the form $E_2^{p,q} = H^{p,0}(X; \underline{H}^{q,r}(pt; M)) \Rightarrow H^{p+q,r}(X; M)$. Set $M = \underline{\mathbb{Z}/2}$ and consider the case $r = 1$. Then $H^{p,0}(X; \underline{H}^{q,r}(pt; \underline{\mathbb{Z}/2})) = 0$ if $q \neq 0, 1$. The case $q = 0$ gives $H^{p,0}(X; \underline{H}^{0,1}(pt; M)) = H^{p,0}(X; \underline{\mathbb{Z}/2})$, and if $q = 1$, $H^{p,0}(X; \underline{H}^{1,1}(pt; \underline{\mathbb{Z}/2})) = H_{sing}^p(X^G; \underline{\mathbb{Z}/2})$. The spectral sequence then has just two non-zero rows as shown in Figure I.1 below.

$q \uparrow$	0	0	0	
	0	0	0	
	0	0	0	
	$H_{sing}^0(X^G)$	$H_{sing}^1(X^G)$	$H_{sing}^2(X^G)$	\dots
	$H^{0,0}(X)$	$H^{1,0}(X)$	$H^{2,0}(X)$	\dots
			$p \rightarrow$	

Fig. I.1: The $r = 1$ spectral sequence for $id: X \rightarrow X$.

As usual, the two row spectral sequence yields the following curious long exact sequence:

$$0 \rightarrow H^{0,0}(X; \underline{\mathbb{Z}/2}) \rightarrow H^{0,1}(X; \underline{\mathbb{Z}/2}) \rightarrow 0 \rightarrow H^{1,0}(X; \underline{\mathbb{Z}/2}) \rightarrow H^{1,1}(X; \underline{\mathbb{Z}/2}) \rightarrow H_{sing}^0(X^G; \underline{\mathbb{Z}/2}) \rightarrow H^{2,0}(X; \underline{\mathbb{Z}/2}) \rightarrow H^{2,1}(X; \underline{\mathbb{Z}/2}) \rightarrow H_{sing}^1(X^G; \underline{\mathbb{Z}/2}) \rightarrow \dots$$

Now, to any equivariant vector bundle $f: E \rightarrow X$, there is an associated

equivariant projective bundle $\mathbb{P}(f): \mathbb{P}(E) \rightarrow X$ whose fibers are lines in the fibers of the original bundle. Applying the above spectral sequence to this new bundle yields the following result, which appears later as Theorem III.6.

Theorem. If X is equivariantly 1-connected and $f: E \rightarrow X$ is a vector bundle with fiber $\mathbb{R}^{n,m}$ over the base point, then the spectral sequence of Theorem III.1 for the bundle $\mathbb{P}(f): \mathbb{P}(E) \rightarrow X$ with constant $M = \underline{\mathbb{Z}/2}$ coefficients “collapses”.

Here, when we say the spectral sequence collapses, we do not mean it collapses in the usual sense. Each fibration $f: E \rightarrow X$ maps to the trivial fibration $id: X \rightarrow X$ in an obvious way. Naturality then provides a map from the spectral sequence for $id: X \rightarrow X$ to the spectral sequence for $f: E \rightarrow X$. In the above theorem, the spectral sequence “collapses” in the sense that the only nonzero differentials are those arising from the trivial fibration $id: X \rightarrow X$. The projective spaces involved are defined in Chapter VII.

In non-equivariant topology, the Leray-Serre spectral sequence gives rise to a description of characteristic classes of vector bundles. Consider the universal bundle $E_n \rightarrow G_n$ over the Grassmannian of n -planes in \mathbb{R}^∞ . Forming the associated projective bundle $\mathbb{P}(E_n) \rightarrow G_n$ yields a fiber bundle with fiber $\mathbb{R}\mathbb{P}^\infty$. Applying the Leray-Serre spectral sequence to this projective bundle yields characteristic classes of E_n as the image of the cohomology classes $1, z, z^2, \dots \in H_{sing}^*(\mathbb{R}\mathbb{P}^\infty; \mathbb{Z}/2)$ under the transgressive differentials. Since this universal bundle classifies vector bundles, characteristic classes of arbitrary bundles can be defined as pullbacks of the characteristic classes, $c_i \in H^i(G_n; \mathbb{Z}/2)$, of the universal bundle. It would be nice to adapt this construction to the $\mathbb{Z}/2$ equivariant setting. However, the equivariant space $G_n((\mathbb{R}^{2,1})^\infty) = G_n(\mathcal{U}) = G_n$ is not 1-connected, and so the spectral sequence is not as easy to work with. It seems

that there is no way to avoid using local coefficient systems in this setting.

Another approach involves using the splitting principle. This yields a map $\mathbb{R}P^\infty \times \cdots \times \mathbb{R}P^\infty \rightarrow G_n(\mathcal{U})$, inducing a map $H^{*,*}(G_n(\mathcal{U})) \rightarrow (H^{*,*}(\mathbb{R}P^\infty) \otimes \cdots \otimes H^{*,*}(\mathbb{R}P^\infty))^{\Sigma_n}$. Here, the Mackey functor is $\underline{\mathbb{Z}/2}$. We then have the following conjecture.

Conjecture. The map

$H^{*,*}(G_n(\mathcal{U}); \underline{\mathbb{Z}/2}) \rightarrow (H^{*,*}(\mathbb{R}P^\infty; \underline{\mathbb{Z}/2}) \otimes \cdots \otimes H^{*,*}(\mathbb{R}P^\infty; \underline{\mathbb{Z}/2}))^{\Sigma_n}$ is an isomorphism.

Chapter II provides some of the definitions and basics that are needed for this paper. The main theorem is stated and proved in Chapter III, making use of some technical homotopical details that are provided in Chapter IV. In Chapter V, the spectral sequence is then applied to compute the cohomology of a projective bundle $\mathbb{P}(E)$ associated to a vector bundle $E \rightarrow X$.

The above conjecture motivates the study of the structure of the $RO(G)$ -graded cohomology of projective spaces in Chapter VII and Grassmann manifolds in Chapter VIII, preceded by a general discussion of $\text{Rep}(G)$ -complexes in Chapter VI.

Chapter IX provides an applications of the $RO(\mathbb{Z}/2)$ -graded Serre spectral sequence to certain loop space. The familiar Leray-Hirsch theorem is extended to the $RO(G)$ -graded setting in Chapter X and is used to compute the cohomology of flag manifolds.

The final chapter, Chapter XI, gives some directions towards a theory of $RO(G)$ -graded characteristic classes.

CHAPTER II

PRELIMINARIES

The section contains some of the basic machinery and notations that will be used throughout the paper. In this section, let G be any finite group.

A G -CW complex is a G -space X with a filtration $X^{(n)}$ where $X^{(0)}$ is a disjoint union of G -orbits and $X^{(n)}$ is obtained from $X^{(n-1)}$ by attaching cells of the form $G/H_\alpha \times \Delta^n$ along maps $f_\alpha: G/H_\alpha \times \partial\Delta^n \rightarrow X^{(n-1)}$. The space $X^{(n)}$ is referred to as the n -skeleton of X . Such a filtration on a space X is called a cell structure for X .

Given a G -representation V , let $D(V)$ and $S(V)$ denote the unit disk and unit sphere, respectively, in V with action induced by that on V . A $\text{Rep}(G)$ -complex is a G -space X with a filtration $X^{(n)}$ where $X^{(0)}$ is a disjoint union of G -orbits and $X^{(n)}$ is obtained from $X^{(n-1)}$ by attaching cells of the form $D(V_\alpha)$ along maps $f_\alpha: S(V_\alpha) \rightarrow X^{(n-1)}$ where V_α is an n -dimensional real representation of G . The space $X^{(n)}$ is again referred to as the n -skeleton of X , and the filtration is referred to as a cell structure.

Let $\Delta_G(X)$ be the category of equivariant simplices of the G -space X . Explicitly, the objects of $\Delta_G(X)$ are maps $\sigma: G/H \times \Delta^n \rightarrow X$. A morphism from σ to $\tau: G/K \times \Delta^m \rightarrow X$ is a pair (φ, α) where $\varphi: G/H \rightarrow G/K$ is a G -map and $\alpha: \Delta^n \rightarrow \Delta^m$ is a simplicial operator such that $\sigma = \tau \circ (\varphi \times \alpha)$.

Let $\Pi_G(X)$ be the fundamental groupoid of X . Explicitly, the objects of $\Pi_G(X)$ are maps $\sigma: G/H \rightarrow X$ and a morphism from σ to $\tau: G/K \rightarrow X$ is a pair (φ, α) where $\varphi: G/H \rightarrow G/K$ is a G -map and α is a G -homotopy class of paths from σ to $\tau \circ \varphi$.

There is a forgetful functor $\pi: \Delta_G(X) \rightarrow \Pi_G(X)$ that sends $\sigma: G/H \times \Delta^n \rightarrow X$ to $\sigma: G/H \rightarrow X$ by restricting to the last vertex e^n of Δ^n . A morphism (φ, α) in $\Delta_G(X)$ is restricted to (φ, α) in $\Pi_G(X)$ by restricting α to the linear path from $\alpha(e^n)$ to e^m in Δ^m . There is a further forgetful functor to the orbit category $\mathcal{O}(G)$, which will also be denoted by π , as shown below.

$$\Delta_G(X) \xrightarrow{\pi} \Pi_G(X) \xrightarrow{\pi} \mathcal{O}(G)$$

A coefficient system on X is a functor $M: \Delta_G(X)^{op} \rightarrow \underline{\text{Ab}}$. We say that the coefficient system M is a local coefficient system if it factors through the forgetful functor to $\Pi_G(X)^{op}$ (up to isomorphism). If M further factors through $\mathcal{O}(G)^{op}$, then we call M a constant coefficient system.

According to [12], each Mackey functor M uniquely determines an $RO(G)$ -graded cohomology theory characterized by

- $H^n(G/H; M) = \begin{cases} M(G/H) & \text{if } n = 0 \\ 0 & \text{otherwise} \end{cases}$
- The map $H^0(G/K; M) \rightarrow H^0(G/H; M)$ induced by $i: G/H \rightarrow G/K$ is the transfer map i^* in the Mackey functor.

Given a Mackey functor M , a G -representation V , and a G -space X , we can form a coefficient system $\underline{H}^V(X; M)$. This coefficient system is determined on objects by $\underline{H}^V(X; M)(G/H) = H^V(X \times G/H; M)$ with maps induced by those in $\mathcal{O}(G)$.

For the precise definition of a Mackey functor for $G = \mathbb{Z}/2$, the reader is referred to [6] or [12]. A summary of the important aspects of a Mackey functor is given here. The data of a Mackey functor are encoded in a diagram like the one below.

$$M(\mathbb{Z}/2) \begin{array}{c} \xrightarrow{\overline{(t^*)}} \\ \xrightarrow{i_*} \\ \xleftarrow{i^*} \end{array} M(e)$$

The maps must satisfy the following four conditions.

- $(t^*)^2 = id$
- $t^*i^* = i^*$
- $i_*(t^*)^{-1} = i_*$
- $i^*i_* = id + t^*$

In this paper, G will usually be $\mathbb{Z}/2$ and the Mackey functor will almost always be constant $M = \underline{\mathbb{Z}/2}$ which has the following diagram.

$$\mathbb{Z}/2 \begin{array}{c} \xrightarrow{\overline{id}} \\ \xrightarrow{0} \\ \xleftarrow{id} \end{array} \mathbb{Z}/2$$

With these constant coefficients, the $RO(\mathbb{Z}/2)$ -graded cohomology of a point is given by the picture in Figure II.1.

Every lattice point in the picture that is inside the indicated cones represents a copy of the group $\mathbb{Z}/2$. The top cone is a polynomial algebra on the

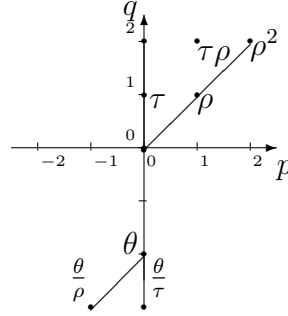
Fig. II.1: $H^{*,*}(pt; \mathbb{Z}/2)$

elements $\rho \in H^{1,1}(pt; \mathbb{Z}/2)$ and $\tau \in H^{0,1}(pt; \mathbb{Z}/2)$. The element θ in the bottom cone is infinitely divisible by both ρ and τ . Details can be found in [6] and [4]. The cohomology of $\mathbb{Z}/2$ is easier to describe: $H^{*,*}(\mathbb{Z}/2; \mathbb{Z}/2) = \mathbb{Z}/2[t, t^{-1}]$ where $t \in H^{0,1}(\mathbb{Z}/2; \mathbb{Z}/2)$.

Given a G -map $f: E \rightarrow X$ and a Mackey functor M , we can define a coefficient system $\mathcal{H}^{q,r}(-, M): \Delta_G(X)^{op} \rightarrow \mathcal{A}b$ by taking cohomology of pullbacks: $\mathcal{H}^{q,r}(f, M)(\sigma) = H^{q,r}(\sigma^*(E), M)$. In [15], it is shown that this is a local coefficient system when f is a G -fibration.

Given a G -fibration $f: E \rightarrow X$, we can define a functor $\Gamma_f: \Delta_G(X) \rightarrow \mathcal{T}op$. On objects, $\Gamma(\sigma) = \sigma^*(E)$. On morphisms, $\Gamma(\varphi, \alpha) = \overline{\varphi \times \alpha}$, where $\overline{\varphi \times \alpha}$ is the map of total spaces in the diagram

$$\begin{array}{ccc} \sigma^*(E) & \xrightarrow{\overline{\varphi \times \alpha}} & \tau^*(E) \\ \downarrow & & \downarrow \\ G/H \times \Delta^n & \xrightarrow{\varphi \times \alpha} & G/K \times \Delta^m. \end{array}$$

Let $f: E \rightarrow X$ be a G -fibration over an equivariantly 1-connected G -space X with base point $x \in X$ and let $F = f^{-1}(x)$. Define a constant coefficient system $\underline{H}^{q,r}(F; M)$ as follows: $\underline{H}^{q,r}(F; M)(G/H) = H^{q,r}((G/H) \times F; M)$ and if $\varphi: G/H \rightarrow G/K$ is a G -map, then $\underline{H}^{q,r}(F; M)(\varphi) = (\varphi \times id)^*$. It is this coefficient system that appears in the spectral sequence of Theorem III.6.

CHAPTER III

CONSTRUCTION OF THE SPECTRAL SEQUENCE

Unlike in ordinary topology, the equivariant Serre spectral sequence for a fibration $f: E \rightarrow X$ will not be deduced from lifting a cellular filtration of X to one on E . Instead, the spectral sequence is a special case of the one for a homotopy colimit. Recall (from [7] for example) that given a cohomology theory \mathcal{E}^* and a diagram of spaces $D: I \rightarrow \mathcal{T}op_G$, there is a natural spectral sequence as follows:

$$E_2^{p,q} = H^p(I^{op}; \mathcal{E}^q(D)) \implies \mathcal{E}^{p+q}(\text{hocolim } D). \quad (\text{III.1})$$

For the case $I = \Delta_G(X)$, we know from [15] that the cohomology of $\Delta_G(X)^{op}$ is the same as Bredon cohomology. For a G -fibration $f: E \rightarrow B$, we can consider the diagram $\Gamma_f: \Delta_G(X) \rightarrow \mathcal{T}op_G$ that sends $\sigma: G/H \times \Delta^n \rightarrow X$ to the pullback $\sigma^*(E)$. We then have the following technical lemma, whose proof is given in the next section where it appears as Lemma IV.4.

Lemma. The composite $\text{hocolim}_{\Delta_G(X)} \Gamma_f \rightarrow \text{colim}_{\Delta_G(X)} \Gamma_f \rightarrow E$ is a weak equivalence.

Here is the desired spectral sequence.

Theorem III.1. *If $f: E \rightarrow X$ is a fibration of G spaces, then for every $V \in RO(G)$ and every Mackey Functor M there is a natural spectral sequence with*

$$E_2^{p,q}(M, V) = H^{p,0}(X; \mathcal{H}^{V+q}(f; M)) \Rightarrow H^{V+p+q}(E; M).$$

Proof. The homotopy colimit spectral sequence of (III.1) associated to Γ_f and the cohomology theory $H^{V+*}(-; M)$ takes the form

$$E_2^{p,q}(M, V) = H^p(\Delta_G(X); \mathcal{H}^{V+q}(\Gamma_f; M)) \Rightarrow H^{V+p+q}(\text{hocolim}(\Gamma_f); M).$$

By [15, Theorem 3.2] and Lemma IV.4, this spectral sequence becomes

$$E_2^{p,q}(M, V) = H^{p,0}(X; \mathcal{H}^{V+q}(f; M)) \Rightarrow H^{V+p+q}(E; M).$$

Naturality of this spectral sequence follows from the naturality of the homotopy colimit spectral sequence. □

The standard multiplicative structure on the spectral sequence is given by the following theorem. Recall that the analogue of tensor product for Mackey functors is the box product, denoted by \square . See, for example, [9] for a full description of the box product.

Theorem III.2. *Given a G -fibration $f: E \rightarrow X$, Mackey functors M and M' and $V, V' \in RO(G)$, there is a natural pairing of the spectral sequences of III.1*

$$E_r^{p,q}(M, V) \otimes E_r^{p',q'}(M'; V') \rightarrow E_r^{p+p',q+q'}(M \square M'; V + V')$$

converging to the standard pairing

$$\cup: H^*(E; M) \otimes H^*(E; M') \rightarrow H^*(E; M \square M').$$

Furthermore, the pairing of E_2 terms agrees, up to a sign $(-1)^{p'q}$, with the standard pairing

$$\begin{array}{c} H^{p,0}(X; \mathcal{H}^{V+q}(f; M)) \otimes H^{p',0}(X; \mathcal{H}^{V'+q'}(f; M')) \\ \cup \downarrow \\ H^{p+p',0}(X; \mathcal{H}^{V+V'+p+p'+q+q'}(f; M \square M')) \end{array}$$

Proof. This is a straightforward application of [15, Theorem 4.1]. \square

Remark III.3. If M is a ring Mackey functor, then the product $M \square M \rightarrow M$ gives a pairing of spectral sequences

$$E_r^{p,q}(M, V) \otimes E_r^{p',q'}(M, V') \rightarrow E_r^{p+p',q+q'}(M, V + V').$$

Remark III.4. Since every G -fibration $f: E \rightarrow X$ maps to the G -fibration $id: X \rightarrow X$, every spectral sequence of Theorem III.1 admits a map from the spectral sequence for the identity of X .

Lemma III.5. *If $f: E \rightarrow X$ is a G -fibration over an equivariantly 1-connected based G -space X , then any local coefficient system \mathcal{A} on X is constant.*

Proof. Choose a base point $x \in X$. Then x can be considered as a map $x: G/G \rightarrow X$. Denote by x_H the point x thought of as a G/H point. That is $x_H = x \circ \pi$ where $\pi: G/H \rightarrow G/G$ is the projection. Notice that if $\varphi: G/H \rightarrow G/K$, then $x_K = x_H \circ \varphi$.

Define a constant coefficient system $\bar{\mathcal{A}}: \mathcal{O}(G) \rightarrow \mathcal{A}b$ by $\bar{\mathcal{A}}(G/H) = \mathcal{A}(x_H)$ and $\bar{\mathcal{A}}(\varphi: G/H \rightarrow G/K) = \mathcal{A}(\varphi, c_x)$, where c_x is the constant path from x_H to x_K . The claim is that \mathcal{A} factors through $\bar{\mathcal{A}}$ up to isomorphism.

For any object $\sigma: G/H \rightarrow X$, the connectivity assumptions ensure that there is one homotopy class of paths from σ to x_H . Let β_σ be a representative path.

For any morphism (φ, α) in $\Pi_G(X)$ from σ to τ , one then has the following commutative diagram:

$$\begin{array}{ccc} \mathcal{A}(\tau) & \xrightarrow{\mathcal{A}(\varphi, \alpha)} & \mathcal{A}(\sigma) \\ \mathcal{A}(id, \beta_\tau) \uparrow & & \uparrow \mathcal{A}(id, \beta_\sigma) \\ \mathcal{A}(x_K) & \xrightarrow{\mathcal{A}(\varphi, c_x)} & \mathcal{A}(x_H). \end{array}$$

Now, each of the vertical maps is an isomorphism since, for example, the path β_σ has the inverse path $\overline{\beta_\sigma}$ and each of the compositions $\beta_\sigma * \overline{\beta_\sigma}$ and $\overline{\beta_\sigma} * \beta_\sigma$ are homotopic to constant paths. The same is true for τ .

Moreover, $(\bar{\mathcal{A}} \circ \pi)(\sigma) = \bar{\mathcal{A}}(G/H) = \mathcal{A}(x_H)$, and $(\bar{\mathcal{A}} \circ \pi)(\varphi, \alpha) = \bar{\mathcal{A}}(\varphi) = \mathcal{A}(\varphi, c_x)$.

This means that the above diagram exhibits an isomorphism from $\bar{\mathcal{A}} \circ \pi \rightarrow \mathcal{A}$. □

Theorem III.6. *If X is equivariantly 1-connected and $f: E \rightarrow X$ is a fibration of G spaces with fiber F , then for every $V \in RO(G)$ and every Mackey Functor M there is a spectral sequence with $E_2^{p,q} = H^{p,0}(X; \underline{H}^{V+q}(F; M)) \Rightarrow H^{V+p+q}(E; M)$.*

Proof. By Theorem III.1 and the above Lemma III.5, it suffices to show that for the local coefficient system $\mathcal{A} = \mathcal{H}^{V+q}(f; M)$, the associated constant coefficient $\bar{\mathcal{A}}$ is $\underline{H}^{V+q}(F; M)$.

Notice that $x_H = x \circ \pi$ and so

$$x_H^* E = (x \circ \pi)^* E = \pi^* x^* E = \pi^* F = (G/H) \times F.$$

We then have

$$\bar{\mathcal{A}}(G/H) = \mathcal{A}(x_H) = H^{V+q}(x_H^* E) = H^{V+q}((G/H) \times F) = \underline{H}^{V+q}(F; M)(G/H). \quad \square$$

CHAPTER IV

HOMOTOPICAL CONSIDERATIONS

What follows is an equivariant version of some of the statements about homotopical decompositions in [7]. These are needed for the proof of Lemma IV.4, and may also be of independent interest. Because of the technical nature of this material, the uninterested reader may skip ahead to the next section.

Consider the category $G\text{-}sSet$ of equivariant simplicial sets. The objects are simplicial sets endowed with a G -action and all of the face and degeneracy maps respect the action. The morphisms are equivariant versions of the usual simplicial maps. An n -simplex of an equivariant simplicial set X is an element $\sigma \in X_n$. Alternatively, we can think of an equivariant n -simplex as an equivariant simplicial map $\sigma: G/H \times \Delta^n \rightarrow X$. Both points of view can be useful.

$G\text{-}sSets$ has a model category structure in which fibrations and weak equivalences are defined in terms of the fixed sets, that is f is a fibration if for all subgroups H the simplicial map f^H is a fibration, and similarly for weak equivalences. The cofibrations are then the maps with the appropriate lifting properties.

Let $D: I \rightarrow G\text{-}sSet$ be a diagram of equivariant simplicial sets. Suppose there is a map $\text{colim}_I D \rightarrow X$. For each simplex $\sigma \in X$ let $F(D)_\sigma$ denote the category whose objects are pairs $[i, \alpha \in (D_i)_n]$ such that the map $D_i \rightarrow X$ sends α

to σ . A map in $F(D)_\sigma$ from $[i, \alpha \in (D_i)_n]$ to $[j, \beta \in (D_j)_n]$ is a map $i \rightarrow j$ such that $D_i \rightarrow D_j$ sends α to β . Then $F(D)_\sigma$ is called the fiber category of D over σ .

Proposition IV.1. *Suppose that $D: I \rightarrow G\text{-sSet}$ and X are as above, and assume that for every $n \geq 0$ and every $\sigma \in X_n$ the fiber category $F(D)_\sigma$ is contractible.*

Then the map $\text{hocolim } D \rightarrow X$ is a weak equivalence of equivariant simplicial sets.

Proof. The proof is nearly identical to that of Proposition 16.9 in [7]. The key facts are that for a bisimplicial set B , the geometric realization satisfies

$|B|^H = |B^H|$ and that weak equivalences are determined by their fixed sets. \square

Now, suppose that $D: I \rightarrow \mathcal{J}op_G$ is a diagram of G -spaces. Suppose we have a map $p: \text{colim } D \rightarrow X$. Then for each $n \geq 0$, each subgroup $H \leq G$ and each $\sigma: G/H \times \Delta^n \rightarrow X$ define the fiber category $F(D)_\sigma$ of D over σ to be the category with objects pairs $[i, \alpha: G/H \times \Delta^n \rightarrow D_i]$ such that $p \circ \alpha = \sigma$. A map from $[i, \alpha: G/H \times \Delta^n \rightarrow D_i]$ to $[j, \beta: G/H \times \Delta^n \rightarrow D_j]$ is a map $i \rightarrow j$ making the obvious diagram commute.

Proposition IV.2. *In the above setting, suppose that for each $n \geq 0$, $H \leq G$, and $\sigma: G/H \times \Delta^n \rightarrow X$ the category $F(D)_\sigma$ is contractible. Then the composite $\text{hocolim } D \rightarrow \text{colim } D \rightarrow X$ is a weak equivalence.*

Proof. A map $\sigma: G/H \times \Delta^n \rightarrow X$ is equivalent to a map $\bar{\sigma}: \Delta^n \rightarrow X^H$. Thus we can reduce to looking at the fixed sets. But, this is exactly Theorem 16.2 in [7]. The condition that $F(D)_\sigma$ is contractible is equivalent to the condition that $F(D)_{\bar{\sigma}}$ is contractible. Thus the composite is a weak equivalence on fixed sets, and so is an equivariant weak equivalence. \square

There is a related simplicial version of the above theorem. Assume that in addition there is a diagram $\tilde{D}: I \rightarrow G\text{-sSet}$ and a natural isomorphism

$\phi_i: |\tilde{D}_i| \rightarrow D_i$. For each $\sigma: G/H \times \Delta^n \rightarrow X$ define the category $\tilde{F}(D)_\sigma$ to have objects pairs $[i, G/H \times \Delta_s^n \rightarrow \tilde{D}_i]$ such that the composite $|G/H \times \Delta_s^n| \rightarrow |\tilde{D}_i| \rightarrow D_i \rightarrow X$ is σ . The morphisms are as expected. Here, $\Delta_s^n \in sSet$ is the n -simplex. The following is a refinement of the previous theorem.

Proposition IV.3. *In the above setting, suppose that for each $n \geq 0$, $H \leq G$, and $\sigma: G/H \times \Delta^n \rightarrow X$ the category $\tilde{F}(D)_\sigma$ is contractible. Then the composite $\text{hocolim } D \rightarrow \text{colim } D \rightarrow X$ is a weak equivalence.*

Proof. Again, we can reduce to looking at fixed sets, this time invoking Proposition 16.3 in [7]. □

For a G -fibration $f: E \rightarrow X$, we can consider the diagram $\Gamma_f: \Delta_G(X) \rightarrow \mathcal{T}op$ that sends $\sigma: G/H \times \Delta^n \rightarrow X$ to the pullback $\sigma^*(E)$. We then have the following technical lemma used in the construction of the spectral sequence.

Lemma IV.4. *The map $\text{hocolim}_{\Delta_G(X)} \Gamma_f \rightarrow \text{colim}_{\Delta_G(X)} \Gamma_f \rightarrow E$ is a weak equivalence.*

Proof. Consider the diagram $D: \Delta_G(X) \rightarrow G\text{-}sSet$ sending $([k], \alpha: G/H \times \Delta^k)$ to the simplicial set obtained as the pull back $G/H \times \Delta_s^n \xrightarrow{\sim} S(G/H \times \Delta^n) \rightarrow S(X) \leftarrow S(E)$, where $S(-)$ is the singular functor.

There is a map of diagrams $|D| \rightarrow \Gamma_f$ which is an objectwise weak equivalence since f is a fibration. We are reduced to showing that $\text{hocolim } |D| \rightarrow \text{colim } |D| \rightarrow E$ is a weak equivalence.

For each $n \geq 0$, $H \leq G$, and $\sigma: G/H \times \Delta^n \rightarrow E$, the category $\tilde{F}(D)_\sigma$ is contractible. This is due to the presence of an initial object associated to the map $f \circ \sigma: G/H \times \Delta^n \rightarrow X$. By Proposition IV.3, we are done. □

CHAPTER V

COHOMOLOGY OF PROJECTIVE BUNDLES

In this chapter, we specialize exclusively to the case where $G = \mathbb{Z}/2$.

To any equivariant vector bundle $f: E \rightarrow X$, there is an associated equivariant projective bundle $\mathbb{P}(f): \mathbb{P}(E) \rightarrow X$ whose fibers are lines in the fibers of the original bundle. Applying the spectral sequence of Theorem III.6 to this new bundle yields the following result:

Theorem V.1. *If X is equivariantly 1-connected and $f: E \rightarrow X$ is a vector bundle with fiber $\mathbb{R}^{n,m}$ over the base point, then the spectral sequence of Theorem III.6 for the bundle $\mathbb{P}(f): \mathbb{P}(E) \rightarrow X$ with constant $M = \underline{\mathbb{Z}/2}$ coefficients “collapses”.*

Here, the spectral sequence “collapses” in the sense that the only nonzero differentials are those arising from the trivial fibration $id: X \rightarrow X$. The projective spaces involved here have actions on them induced by the action in the fibers. Briefly, we denote by $\mathbb{R}\mathbb{P}_{tw}^n = \mathbb{P}(\mathbb{R}^{n+1, \lfloor \frac{n+1}{2} \rfloor})$, the equivariant space of lines in $\mathbb{R}^{n+1, \lfloor \frac{n+1}{2} \rfloor}$. For the other projective spaces, we simply denote the space of lines in $\mathbb{R}^{n,m}$ by $\mathbb{P}(\mathbb{R}^{n,m})$. These projective spaces themselves are studied in more detail in Chapter VII.

Proof. By Lemma VII.6 we need only consider the case where $n \geq m/2$.

First, consider the case where the vector bundle has fiber $\mathbb{R}^{n, \lfloor \frac{n}{2} \rfloor}$ over the base point.

If n is odd, consider the vector bundle $E \oplus \mathbb{R}^{1,0} \rightarrow X$, and if n is even consider $E \oplus \mathbb{R}^{1,1} \rightarrow X$. In either case, denote this new bundle by $E \oplus L$. Taking the associated projective bundles gives a diagram

$$\begin{array}{ccccc}
 \mathbb{R}\mathbb{P}_{tw}^{n-1} & \longrightarrow & \mathbb{R}\mathbb{P}_{tw}^n & \longrightarrow & pt \\
 \downarrow & & \downarrow & \swarrow s & \downarrow \\
 \mathbb{P}(E) & \longrightarrow & \mathbb{P}(E \oplus L) & \xrightarrow{\mathbb{P}(f)} & X \\
 \downarrow & & \downarrow \mathbb{P}(f) & \nearrow s & \downarrow id \\
 X & \xrightarrow{id} & X & \xrightarrow{id} & X
 \end{array}$$

Here and below pt is the one point set with trivial $\mathbb{Z}/2$ action. The map s above is the canonical splitting that assigns to each point x in X the line given by the trivial factor in $E \oplus L$. It is important to note that this is indeed an equivariant splitting in both the case of $\mathbb{R}^{1,0}$ and $\mathbb{R}^{1,1}$. This diagram yields maps between the spectral sequences associated to these three bundles over X . Let us consider the $r = 1$ spectral sequence for $\mathbb{P}(E \oplus L)$. This is the sequence with E_2 -page given by

$$E_2^{p,q} = H^{p,0}(X; \underline{H}^{q,1}(\mathbb{R}\mathbb{P}_{tw}^n)) \Rightarrow H^{p+q,1}(\mathbb{P}(E \oplus L)).$$

This spectral sequence is generated as an algebra over $H^{*,*}(pt)$ by the classes $a \in H^{0,0}(X; H^{1,1}(\mathbb{R}\mathbb{P}_{tw}^n))$ and $b \in H^{0,0}(X; H^{2,1}(\mathbb{R}\mathbb{P}_{tw}^n))$. To see that the spectral sequence collapses, we need only see that these classes a and b have trivial differentials.

The splitting s induces a map s^* from the $r = 1$ spectral sequences associated to the bundle $f : \mathbb{P}(E) \rightarrow X$ to the one for the trivial bundle $id : X \rightarrow X$. This map sends the class $a \in H^{0,0}(X; H^{1,1}(\mathbb{R}\mathbb{P}_{tw}^n))$ to $0 \in H^{0,0}(X; H^{1,1}(pt))$ since $s^* : H^{*,*}(\mathbb{R}\mathbb{P}_{tw}^n) \rightarrow H^{*,*}(pt)$ is the projection. Thus

$s^*da = d(s^*a) = 0$. However, s^* gives an isomorphism between coefficient systems

$\underline{H}^{0,1}(\mathbb{RP}_{tw}^n) \cong_{s^*} \underline{H}^{0,1}(pt)$. Observe:

$$\begin{aligned}
(\underline{H}^{0,1}(\mathbb{RP}_{tw}^n))(\mathbb{Z}/2) &= H^{0,1}(\mathbb{Z}/2 \times \mathbb{RP}_{tw}^n) \\
&= [\mathbb{Z}/2 \times \mathbb{RP}_{tw}^n, K(\mathbb{Z}/2(1), 0)]_{\mathbb{Z}/2} \\
&= [\mathbb{RP}_{tw}^n, K(\mathbb{Z}/2, 0)]_e \\
&= H_{sing}^0(\mathbb{RP}^n; \mathbb{Z}/2) \\
&\cong_{s^*} H_{sing}^0(pt; \mathbb{Z}/2) \\
&= H^{0,1}(pt) \\
&= (\underline{H}^{0,1}(pt))(\mathbb{Z}/2).
\end{aligned}$$

Here, $K(A(q), p)$ is the representing space for $H^{p,q}(-; \underline{A})$.

Also, $\underline{H}^{0,1}(\mathbb{RP}_{tw}^n)(G/G) = H^{0,1}(\mathbb{RP}_{tw}^n) \cong_{s^*} H^{0,1}(pt)$. It now follows that

since $s^*da = 0$, it must be that $da = 0$.

Now, from the relation $a^2 = \rho a + \tau b$ we get that $0 = d(a^2) = \rho da + \tau db$.

Hence $\tau db = 0$. But, $\tau: \underline{H}^{1,1}(\mathbb{RP}_{tw}^n) \rightarrow \underline{H}^{1,2}(\mathbb{RP}_{tw}^n)$ is an isomorphism. Thus $db = 0$.

Now, $\mathbb{P}(i)^*(a) = a$ and $\mathbb{P}(i)^*(b) = b$, where $\mathbb{P}(i)^*: \mathbb{P}(E \oplus L) \rightarrow \mathbb{P}(E)$. Thus $d(a) = 0$ and $d(b) = 0$ in the spectral sequence for $\mathbb{P}(E)$ as well. Therefore the spectral sequence ‘‘collapses,’’ in the sense that all differentials are zero, except for the part of the spectral sequence corresponding to the trivial fibration $id: X \rightarrow X$.

For the other projective spaces, we can proceed inductively. Fix m and induct on $n \geq m/2$. The base case is exactly the argument above. For the inductive step, in going from $\mathbb{P}(\mathbb{R}^{n,m})$ to $\mathbb{P}(\mathbb{R}^{n+1,m})$, a single new cohomology generator $c_{n,m}$ appears in degree (n, m) , according to Lemma VII.8. Also, by Proposition VII.10, we have $ac_{n-1,m} = \tau c_{n,m}$, where $c_{n-1,m}$ is the highest dimensional cohomology generator in $H^{*,*}(\mathbb{P}(\mathbb{R}^{n,m}))$. Then in the spectral sequence we have $d(ac_{n-1,m}) = \tau d(c_{n,m})$. But, by induction, $d(ac_{n-1,m}) = 0$. Since $\cdot\tau$ is still an injection in the range we are working in, it must be that $d(c_{n,m}) = 0$.

This gives the desired collapsing of the spectral sequence. \square

In fact, we can deduce even more about such a projective bundle.

Corollary V.2. *If $f: E \rightarrow X$ is a vector bundle with X equivariantly 1-connected with fiber $\mathbb{R}^{n,m}$ over the base point, then $\mathbb{P}(F)^*: H^{*,*}(X) \rightarrow H^{*,*}(\mathbb{P}(E))$ is an injection.*

Proof. By the preceding theorem, there is a natural injection of the spectral sequence for id_X into the one for $\mathbb{P}(f)$, thus an injection on the filtrations. We get an injection on the E_∞ terms, and thus, by the following lemma, an injection $H^{*,*}(X) \rightarrow H^{*,*}(\mathbb{P}(E))$. \square

Lemma V.3. *Let $f: E_r^{p,q} \rightarrow F_r^{p,q}$ be a map of first quadrant spectral sequences, converging to A_{p+q} and B_{p+q} respectively, which is an injection for every p, q , and r . Then f induces an injection $\tilde{f}: A_{p+q} \rightarrow B_{p+q}$.*

Proof. Fix n . Then there is a filtration $0 \subseteq A_0 \subseteq \cdots \subseteq A_n$ with $A_i/A_{i-1} \cong E_\infty^{n-i,i}$. Similarly, there is a filtration $0 \subseteq B_0 \subseteq \cdots \subseteq B_n$ with $B_i/B_{i-1} \cong F_\infty^{n-i,i}$. Notice that $A_0 = E_\infty^{n,0}$ and $B_0 = F_\infty^{n,0}$. Thus $\tilde{f}_0: A_0 \rightarrow B_0$ is injective. Induction starts.

Suppose that $\tilde{f}_i: A_i \rightarrow B_i$ is injective. We also know that $f_{i+1}: A_{i+1}/A_i \rightarrow B_{i+1}/B_i$ is injective. We have a map $\tilde{f}_{i+1}: A_{i+1} \rightarrow B_{i+1}$ that restricts to \tilde{f}_i and we want to see that \tilde{f}_{i+1} is injective. Suppose $\tilde{f}_{i+1}(a) = 0$. Then $f_{i+1}([a]) = 0$. But this map is injective, so $a \in A_i$. Since \tilde{f}_{i+1} restricts to \tilde{f}_i on A_i , we have that $\tilde{f}_{i+1}(a) = \tilde{f}_i(a) = 0$. As \tilde{f}_i is injective, $a = 0$. By induction, $\tilde{f}_n = \tilde{f}$ is injective. \square

CHAPTER VI

REP(G)-COMPLEXES

Computing the $RO(G)$ -graded cohomology of a G -space X is typically quite a difficult task. However, if X has a filtration $X^{(0)} \subseteq X^{(1)} \subseteq \dots$, then we can take advantage of the long exact sequences arising from the cofiber sequences $X^{(n)} \subseteq X^{(n+1)} \rightarrow X^{(n+1)}/X^{(n)}$. These sequences paste together as an exact couple in the usual way, giving rise to a spectral sequence associated to the filtration. We will only be interested in the case $G = \mathbb{Z}/2$. In this case, for each fixed q there is a long exact sequence

$$\dots H^{*,q}(X^{(n+1)}/X^{(n)}) \rightarrow H^{*,q}(X^{(n+1)}) \rightarrow H^{*,q}(X^{(n)}) \rightarrow H^{*+1,q}(X^{(n+1)}/X^{(n)}) \dots$$

and so there is one spectral sequence for each q . The specifics are given in the following proposition.

Proposition VI.1. *Let X be a filtered $\mathbb{Z}/2$ -space. Then for each q there is a spectral sequence with*

$$E_1^{p,n} = H^{p,q}(X^{(n+1)}, X^{(n)}; M)$$

converging to $H^{p,q}(X; M)$.

For a proof, see, for example, Proposition 5.3 of [13]. The result above is

dual to the homological result, and is, of course, for a cohomology theory other than singular cohomology, but the construction is exactly the same.

For $\mathbb{Z}/2$ -spaces, it is convenient to plot the cohomology in the plane with p along the horizontal axis and q along the vertical axis. This turns out to be a nice way to view the above spectral sequences as well. However, it is important to keep track of at what stage of the filtration each group arises. After doing so, the differential on each page of the spectral sequence has bidegree $(1, 0)$ in the plane, but reaches farther up the filtration on each page.

If X is a G -CW complex or a $\text{Rep}(G)$ -complex, then X has a natural filtration coming from the cell structure. In either case, if X is connected, the quotient spaces $X^{(n+1)}/X^{(n)}$ are wedges of $(n + 1)$ -spheres with action determined by the type of cells that were attached. Examples of this sort appear below and in the next few chapters.

Another useful tool for computing is the following exact sequence of [1].

Lemma VI.2 (Forgetful Long Exact Sequence). *Let X be a based $\mathbb{Z}/2$ -space. Then for every q there is a long exact sequence*

$$\dots \longrightarrow H^{p,q}(X) \xrightarrow{\cdot\rho} H^{p+1,q+1}(X) \xrightarrow{\psi} H_{sing}^{p+1}(X) \xrightarrow{\delta} H^{p+1,q}(X) \longrightarrow \dots$$

The map $\cdot\rho$ is multiplication by $\rho \in H^{1,1}(pt; \underline{\mathbb{Z}/2})$ and ψ is the forgetful map to singular cohomology with $\mathbb{Z}/2$ coefficients.

Here, only the generator associated to the (p, q) -cell and the generators with nonzero differentials are shown. There could, of course, be more than are shown, and in different dimensions. This picture is only to facilitate the conversation. Each of the ω_i satisfies $d(\omega_i) = \tau^{n_i}\nu$ for integers n_i . Relabeling if necessary, we can arrange so that the ω_i satisfy $n_1 \leq n_2 \leq \dots$. Then, after a change of basis, we can assume that $d(\omega_1) = \tau^{n_1}\nu$ and $d(\omega_i) = 0$ for $i > 1$. In effect, the attaching map can slide off of all the ω_i except for one for which q_i is minimal. If ω_1 happens to be in dimension $(p-1, q)$, then the newly attached cell ‘kills’ ω_1 and ν . (This happens, for example, in certain $\text{Rep}(\mathbb{Z}/2)$ -cell structures for $D(\mathbb{R}^{p,q})$.) Otherwise, after the above adjustment, the nonzero portions of the spectral sequence are given in Figure VI.2.

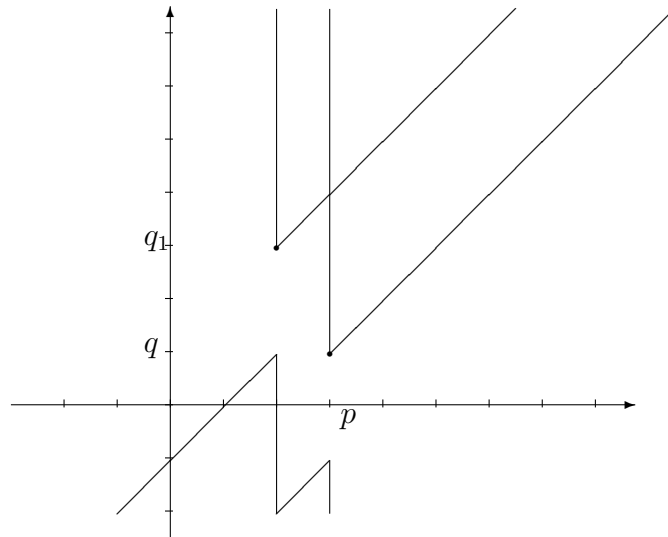

Fig. VI.2: The nonzero portion of the same spectral sequence, after a change of basis.

After taking cohomology, the spectral sequence collapses, and we have Figure VI.3.

As we will see with the Grassmannians, nonzero differentials can shift

a single (p, q) -cell ν , then after an appropriate change of basis either all attaching maps to the top cone of ν are zero (that is, $d(a) = 0$ for all a with $a \in H^{*,q_a}(B)$ with $q_a \geq q - 1$), the cell attaching ‘kills’ ν and a free generator in dimension $(p - 1, q)$, or all nonzero differentials hit the bottom cone of ν .

The behavior on the bottom cone is more interesting and, according to the previous lemma, this is in fact where all of the nonzero differentials must occur. For the attaching maps in the bottom cone, we can, again, slide the map off of some of the generators in certain relative positions. Before going into the general details, let’s consider an example first. Consider the space X formed by attaching a single (p, q) -cell to a space B where $\tilde{H}^{*,*}(B) = \tilde{H}^{*,*}(S^{p-1, q-2})$ generated by ω . There is a cofiber sequence $B \xrightarrow{i} X \xrightarrow{j} S^{p, q}$. Denote by ν the generator of $H^{*,*}(S^{p, q})$. The E_1 page of the cellular spectral sequence is in Figure VI.4.

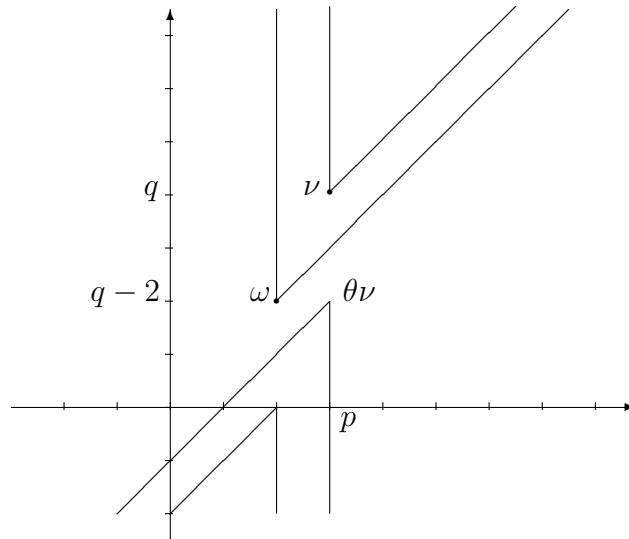

Fig. VI.4: An example where the nonzero differential hits the ‘tip’ of the bottom cone.

There is a single nonzero differential $d(\omega) = \theta\nu$. After taking cohomology,

the spectral sequence collapses and we have Figure VI.5.

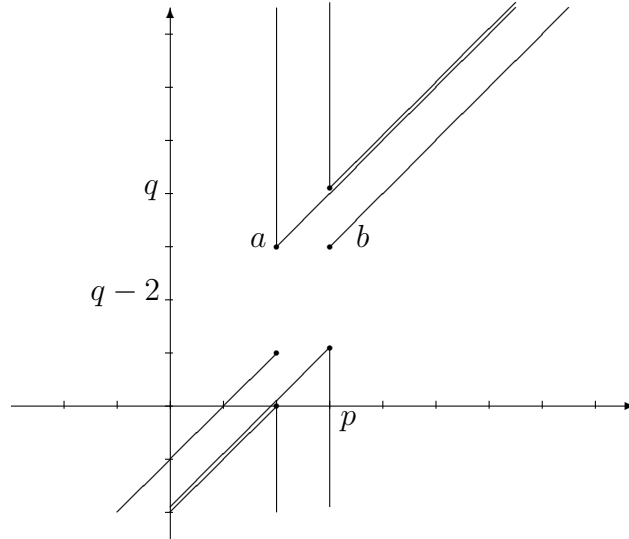

Fig. VI.5: The $E_2 = E_\infty$ page of the above spectral sequence.

Denote by a the generator in degree $(p-1, q-1)$ and by b the one in degree $(p, q-1)$. Notice that b is not in the image of $\cdot\rho$. By the forgetful long exact sequence, b determines a nonzero class in singular cohomology, and so $\tau^n b$ is nonzero for all n . In particular, ρa and τb generate $H^{p,q}(X)$. Consider the portion of the long exact sequence associated to the cofiber sequence $B \xrightarrow{i} X \xrightarrow{j} S^{p,q}$ given below:

$$\dots \longrightarrow H^{p,q}(S^{p,q}) \xrightarrow{j^*} H^{p,q}(X) \xrightarrow{i^*} H^{p,q}(B) \longrightarrow 0$$

Since $i^*(\rho a) = i^*(\tau b) = \rho\tau\omega$, exactness implies that $j^*(\nu) = \rho a + \tau b$. Also j^* is an $H^{*,*}(pt)$ -module homomorphism, and so $j^*(\frac{\theta}{\rho}\nu) = \theta a$ and $j^*(\frac{\theta}{\tau}\nu) = \theta b$. In particular, we can create a map f from a free module with generators α and β in dimensions $(p-1, q-1)$ and $(p, q-1)$ respectively to $\tilde{H}^{p,q}(X)$ with $f(\alpha) = a$ and $f(\beta) = b$. The previous calculation implies that f is in fact an isomorphism. This

is a special case of the following proposition.

Proposition VI.4. *Suppose X is a $\text{Rep}(\mathbb{Z}/2)$ -complex formed by attaching a single (p, q) -cell to a space B . Suppose also that $\tilde{H}^{*,*}(B)$ is a free $H^{*,*}(pt)$ -module with a single generator ω of dimension smaller than p . Then $H^{*,*}(X)$ is a free $H^{*,*}(pt)$ -module. In particular, one of the following must hold:*

1. $H^{*,*}(X) \cong H^{*,*}(pt)$.
2. $H^{*,*}(X) \cong H^{*,*}(B) \oplus \Sigma^\nu H^{*,*}(pt)$, where the degree of ν is (p, q) .
3. $H^{*,*}(X)$ is free with two generators a and b .

In (3) above, the dimensions of the generators a and b are $(p - n - 1, q - n - 1)$ and $(p, q - m - 1)$ where $d(\omega) = \frac{\theta}{\rho^n \tau^m} \nu$.

Proof. Under these hypotheses, there is a cofiber sequence of the form $B \xrightarrow{i} X \xrightarrow{j} S^{p,q}$. Denote by ν the generator of $H^{*,*}(S^{p,q})$.

If $d(\omega) = \nu$ then (1) holds and $H^{*,*}(X)$ is free. If $d(\omega) = 0$, then (2) holds and again $H^{*,*}(X)$ is free. The remaining case is $d(\omega) \neq 0$. By the above discussion, this must mean that the nonzero differentials must be in the bottom cone and so $d(\omega) = \frac{\theta}{\rho^n \tau^m} \nu$ for some n and m . Recall that ν has dimension (p, q) and so ω has dimension $(p - n - 1, q - n - m - 2)$. The E_1 page of the cellular spectral sequence is given in Figure VI.6.

After taking cohomology, the spectral sequence collapses, and what remains is pictured in Figure VI.7.

Here, a has dimension $(p - n - 1, q - n - 1)$ and b has dimension $(p, q - m - 1)$. For purely dimensional reasons, b is not in the image of $\cdot \rho$ and so determines a nonzero class in singular cohomology. Thus, $\tau^i b$ is nonzero for all i , and so we have that $b_i = \tau^i b$. In particular, $\rho^{n+1} a$ and $\tau^m b$ generate $H^{p,q}(X)$.

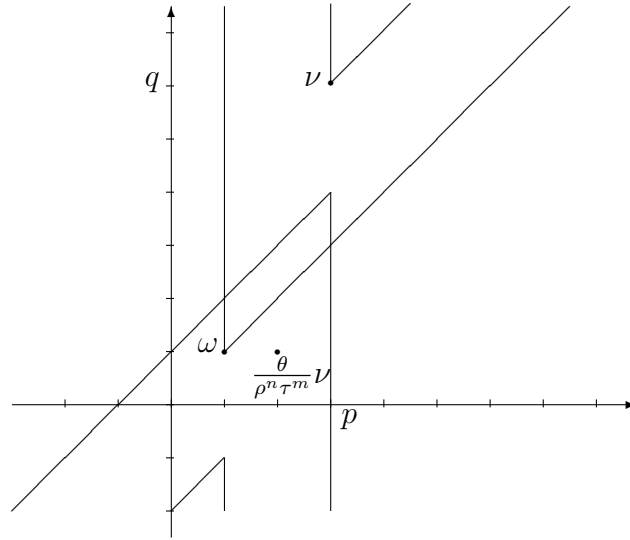

Fig. VI.6: The E_1 page of the cellular spectral sequence with a single nonzero differential hitting the bottom cone of an attached (p, q) -cell.

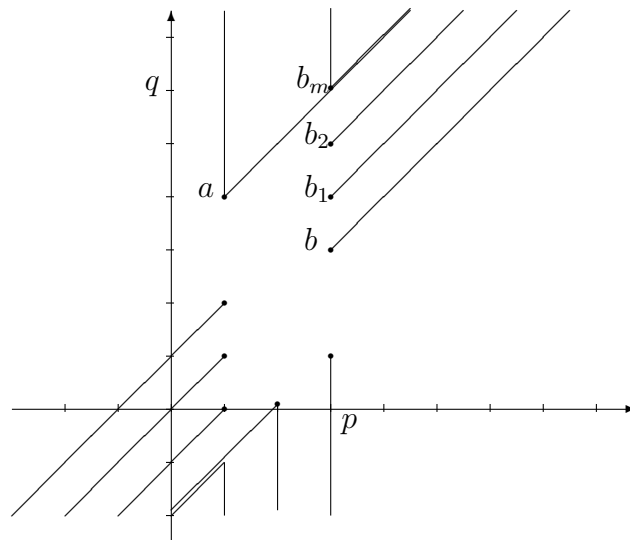

Fig. VI.7: The $E_2 = E_\infty$ page of the cellular spectral sequence with a single nonzero differential hitting the bottom cone of an attached (p, q) -cell.

Consider the portion of the long exact sequence associated to the cofiber sequence

$B \xrightarrow{i} X \xrightarrow{j} S^{p,q}$ given below:

$$\cdots \longrightarrow H^{p,q}(S^{p,q}) \xrightarrow{j^*} H^{p,q}(X) \xrightarrow{i^*} H^{p,q}(B) \longrightarrow 0$$

Since $i^*(\rho^{n+1}a) = i^*(\tau^m b) = \rho^{n+1}\tau^m\omega$, exactness implies that

$j^*(\nu) = \rho^{n+1}a + \tau^m b$. Also j^* is an $H^{*,*}(pt)$ -module homomorphism, and so $j^*(\frac{\theta}{\rho^{n+1}}\nu) = \theta a$ and $j^*(\frac{\theta}{\tau^m}\nu) = \theta b$. In particular, we can create a map f from a free module with generators α and β in dimensions $(p - n - 1, q - n - 1)$ and $(p, q - m - 1)$ respectively to $\tilde{H}^{p,q}(X)$ with $f(\alpha) = a$ and $f(\beta) = b$. This f is an isomorphism.

□

Theorem VI.5 (Freeness Theorem). *If X is a connected, locally finite, finite dimensional $\text{Rep}(\mathbb{Z}/2)$ -complex, then $H^{*,*}(X; \underline{\mathbb{Z}/2})$ is free as a $H^{*,*}(pt; \underline{\mathbb{Z}/2})$ -module.*

Proof. The Mackey functor $\underline{\mathbb{Z}/2}$ will be assumed throughout and so will be dropped from the notation.

Since X is locally finite, the cells can be attached one at a time. Order the cells $\alpha_1, \alpha_2, \dots$ so that their dimensions satisfy $p_i \leq p_j$ if $i \leq j$ and $q_i \leq q_j$ if $p_i = p_j$ and $i \leq j$. We can proceed by induction over the spaces in the filtration $X^{(0)} \subseteq \cdots \subseteq X^{(n)} \subseteq \cdots \subseteq X$, with the base case obvious since X is connected.

First, suppose that $H^{*,*}(X^{(n)})$ is a free $H^{*,*}(pt)$ -module and that $X^{(n+1)}$ is obtained by attaching a single (p, q) -cell and that $X^{(n)}$ has no p -cells. Denote by ν the free generator of $H^{*,*}(X^{(n+1)}/X^{(n)}) \cong H^{*,*}(S^{p,q})$. Consider the spectral sequence of the filtration $X^{(n)} \subseteq X^{(n+1)}$. This is pictured below in Figure VI.8

A change of basis allows us to choose a subset $\omega_1, \dots, \omega_n$ of the free

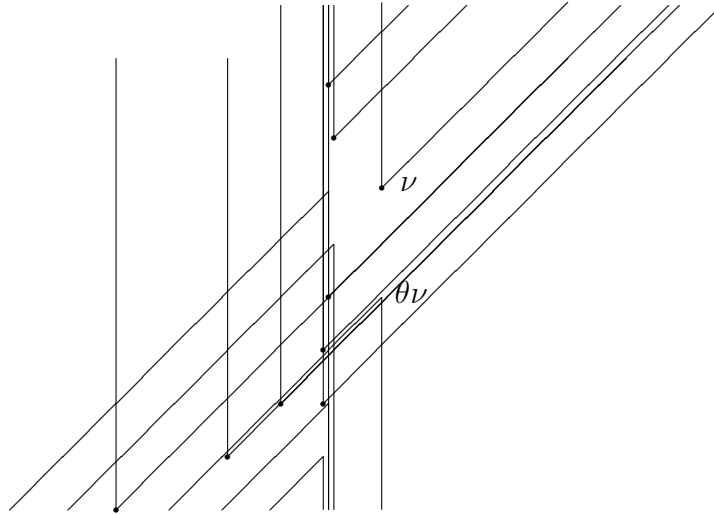

Fig. VI.8: The spectral sequence of a filtration for attaching a single (p, q) -cell to a space with free cohomology.

generators of $H^{*,*}(X^{(n)})$ whose differentials hit the bottom cone of ν and that satisfy

- $d(\omega_i) \neq 0$ for all i ,
- $|\omega_i| > |\omega_j|$ when $i > j$,
- $|\omega_i^G| > |\omega_j^G|$ when $i > j$,

and all other basis elements have zero differentials to the bottom cone of ν . This is similar to what is referred to in [9] as a ramp of length n . Also, we can change the basis again so that there is only one free generator, α , of $H^{*,*}(X^{(n)})$ with a nonzero differential to the top cone of ν . Then, after this change of basis, the nonzero portion of the spectral sequence of the filtration looks like the one in Figure VI.9

Using an argument very similar to the one above, α cannot support a nonzero differential, and we can see that each of the ω_i 's will shift up in degree and

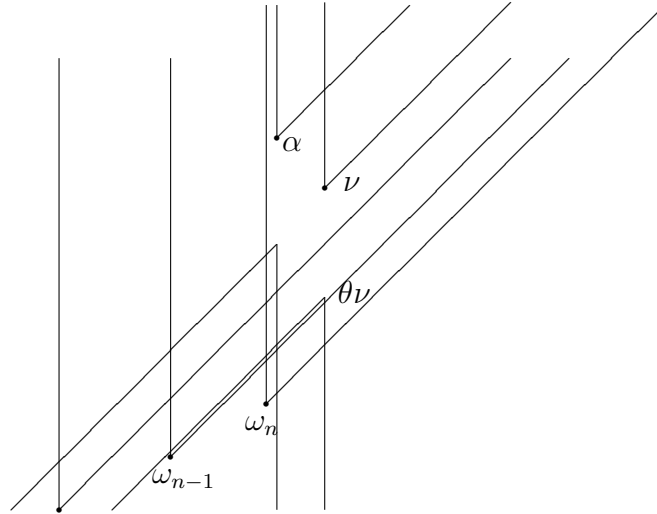

Fig. VI.9: The nonzero portion of the above spectral sequence, after a change of basis.

ν will shift down. Thus, $H^{*,*}(X^{(n+1)})$ is again free.

Now suppose that $X^{(n+1)}$ is obtained by attaching a (p, q) -cell ν' and that $X^{(n)}$ has a single p -cell ν already. Then by the previous case, the generator for ν was either shifted down, killed off, or was left alone at the previous stage. In any case, because of our choice of ordering of the cells, the generator for ν cannot support a differential to the generator for ν' . Thus, the only nonzero differentials to ν' are from strictly lower dimensional cells. Thus, we are reduced again to the previous case and $H^{*,*}(X^{(n+1)})$ is free. By induction, $H^{*,*}(X)$ is free. \square

Corollary VI.6. *Real and complex projective spaces and Grassmann manifolds have free cohomology with $\underline{\mathbb{Z}/2}$ coefficients.*

CHAPTER VII

COHOMOLOGY OF REAL PROJECTIVE SPACES

In this section, $G = \mathbb{Z}/2$ exclusively.

Recall that $\mathbb{R}P_{tw}^\infty = G_1(\mathcal{U})$, the space of lines in the complete universe \mathcal{U} . In this section we compute the cohomology of real projective spaces, in particular we compute $H^{*,*}(\mathbb{R}P_{tw}^\infty; \underline{\mathbb{Z}/2})$. The Mackey functor in this section will always be $M = \underline{\mathbb{Z}/2}$ and will be suppressed from the notation.

Theorem VII.1. $H^{*,*}(\mathbb{R}P_{tw}^\infty) = H^{*,*}(pt)[a, b]/(a^2 = \rho a + \tau b)$, where $\deg(a) = (1, 1)$ and $\deg(b) = (2, 1)$.

First, a $\mathbb{Z}/2$ -representation space structure for $\mathbb{R}P_{tw}^\infty$ is obtained by considering $\mathbb{R}P_{tw}^\infty$ as a limit of certain other projective spaces. Denote by $\mathbb{R}P_{tw}^n = \mathbb{P}(\mathbb{R}^{n+1}, \lfloor \frac{n+1}{2} \rfloor)$, the equivariant space of lines in $\mathbb{R}^{n+1}, \lfloor \frac{n+1}{2} \rfloor$. For example, $\mathbb{R}P_{tw}^3 = \mathbb{P}(\mathbb{R}^{4,2})$, $\mathbb{R}P_{tw}^4 = \mathbb{P}(\mathbb{R}^{5,2})$, and $\mathbb{R}P_{tw}^1 = S^{1,1}$. There are natural inclusions $\mathbb{R}P_{tw}^n \rightarrow \mathbb{R}P_{tw}^{n+1}$ which, by the following lemma, are cellular.

Lemma VII.2. $\mathbb{R}P_{tw}^n$ has a $\mathbb{Z}/2$ -representation space structure with cells in dimension $(0, 0)$, $(1, 1)$, $(2, 1)$, $(3, 2)$, $(4, 2)$, \dots , $(n, \lfloor \frac{n}{2} \rfloor)$.

Proof. Consider a Schubert cell decomposition using the filtration

$\mathbb{R}^n, \lfloor \frac{n}{2} \rfloor = \mathbb{R}^{1,0} \oplus \mathbb{R}^{1,1} \oplus \mathbb{R}^{1,0} \oplus \mathbb{R}^{1,1} \oplus \dots$. This decomposition ends in either $\mathbb{R}^{1,0}$ or $\mathbb{R}^{1,1}$ according to the parity of n .

Proceed by induction. For the case $n = 1$, a line in $\mathbb{R}^{1,0} \oplus \mathbb{R}^{1,1}$ is either the span of $(1, 0)$, giving the $(0,0)$ -cell, or the span $\langle(a, 1)\rangle$ of a vector $(a, 1)$. The action of $\mathbb{Z}/2$ sends $\langle(a, 1)\rangle \mapsto \langle(a, -1)\rangle = \langle(-a, 1)\rangle$. Thus we have a $(1,1)$ -cell. Induction starts.

Inductive step: $\mathbb{R}\mathbb{P}_{tw}^n$ is obtained from $\mathbb{R}\mathbb{P}_{tw}^{n-1}$ by attaching a single $(n, ?)$ -cell. It remains to determine the number of twistings.

Suppose n is even. Then the points in the attached cell are of the form $(x_1, x_2, \dots, x_n, 1)$. The $\mathbb{Z}/2$ action sends $(x_1, x_2, \dots, x_n, 1) \mapsto (x_1, -x_2, \dots, -x_n, 1)$. Thus we have attached an $(n, \frac{n}{2})$ -cell.

Suppose n is odd. Then the points in the attached cell are of the form $(x_1, x_2, \dots, x_n, 1)$. The $\mathbb{Z}/2$ action sends $(x_1, x_2, \dots, x_n, 1) \mapsto (x_1, -x_2, \dots, x_n, -1) = (-x_1, x_2, \dots, -x_n, 1)$. Thus we have attached an $(n, \frac{n+1}{2})$ -cell. \square

This lemma can also be proven with the use of Proposition VIII.1.

The above lemma implies that $\mathbb{R}\mathbb{P}_{tw}^\infty$ has a cell structure with a single cell in dimension $(n, \lceil \frac{n}{2} \rceil)$, for all $n \in \mathbb{N}$. This is simply because of the inclusions $\mathbb{R}\mathbb{P}_{tw}^1 \hookrightarrow \mathbb{R}\mathbb{P}_{tw}^2 \hookrightarrow \dots$, the colimit of which is $\mathbb{R}\mathbb{P}_{tw}^\infty$.

To compute the cohomology from these cell structures, the spectral sequence associated to the cellular filtration will be of particular use. Recall that all differentials on all pages of this spectral sequence have degree $(1, 0)$.

Lemma VII.3. *As a $H^{*,*}(pt)$ -module, $H^{*,*}(\mathbb{R}\mathbb{P}_{tw}^n)$ is free with a single generator in dimension $(k, \lceil \frac{k}{2} \rceil)$ for $k = 0, 1, \dots, n$.*

Proof. It suffices to show that the free generators $a_{(k, \lceil \frac{k}{2} \rceil)}$ associated to the $(k, \lceil \frac{k}{2} \rceil)$ -cell map to zero in the spectral sequence associated to the cellular filtration $X^0 \subseteq X^1 \subseteq \dots \subseteq X^n = \mathbb{R}\mathbb{P}_{tw}^n$. It will then follow from the module

structure that $d(\lambda \cdot a_{(k, \lceil \frac{k}{2} \rceil)}) = 0$ for all $\lambda \in H^{*,*}(pt)$, and the result immediately follows.

We will proceed by induction on the dimension.

The base case $n = 1$ is immediate, since $d(a_{1,1}) \in H^{2,1}(X^2/X^1)$, But, $\mathbb{R}P_{tw}^1$ has no 2-cells, and so $d(a_{1,1}) = 0$. Induction starts.

Now, suppose $n > 1$. We divide into even and odd cases. If n is odd, then Figure VII.1 gives a picture of the E_1 page of the cellular spectral sequence for $\mathbb{R}P_{tw}^n$.

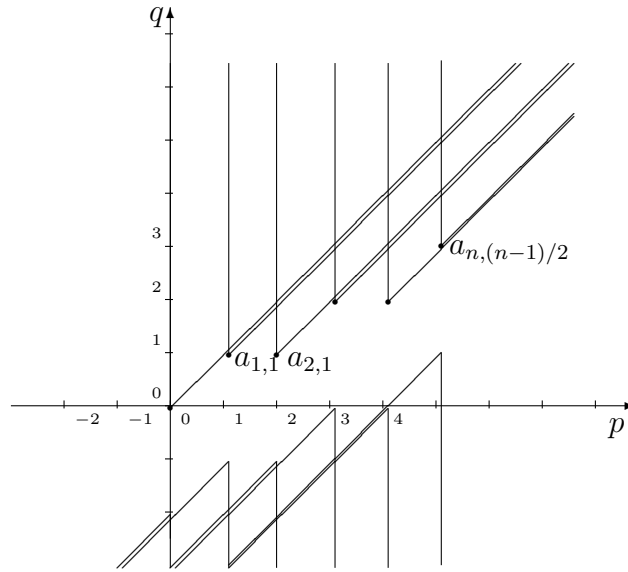

Fig. VII.1: The E_1 page of the cellular spectral sequence for $\mathbb{R}P_{tw}^n$ for n odd.

By induction, we know that each of the $d(a_{(k, \lceil \frac{k}{2} \rceil)}) = 0$ for $k < n$, since restriction to the smaller dimensional projective space sends $a_{(k, \lceil \frac{k}{2} \rceil)}$ to $a_{(k, \lceil \frac{k}{2} \rceil)}$. For purely dimensional reasons, we must have that $d(a_{(n, \lceil \frac{n}{2} \rceil)}) = 0$.

If n is even, the E_1 page of the cellular spectral sequence for $\mathbb{R}P_{tw}^n$ is pictured in Figure VII.2.

Again, by induction we know that each of the $d(a_{(k, \lceil \frac{k}{2} \rceil)}) = 0$ for $k < n - 1$.

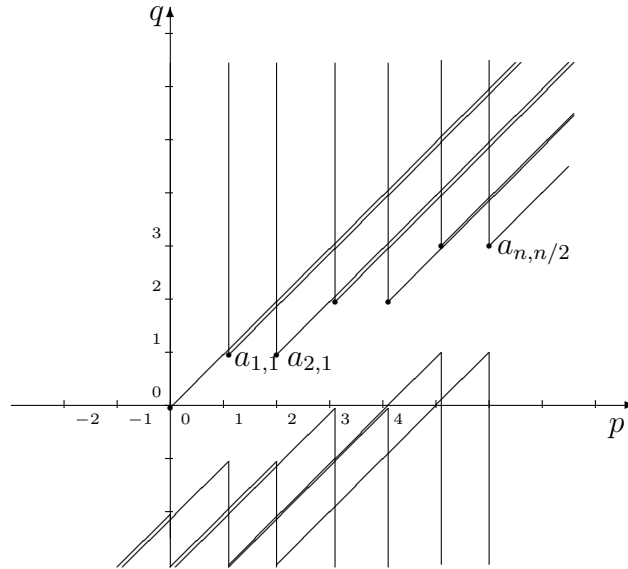

Fig. VII.2: The E_1 page of the cellular spectral sequence for $\mathbb{R}P^n$ for n even.

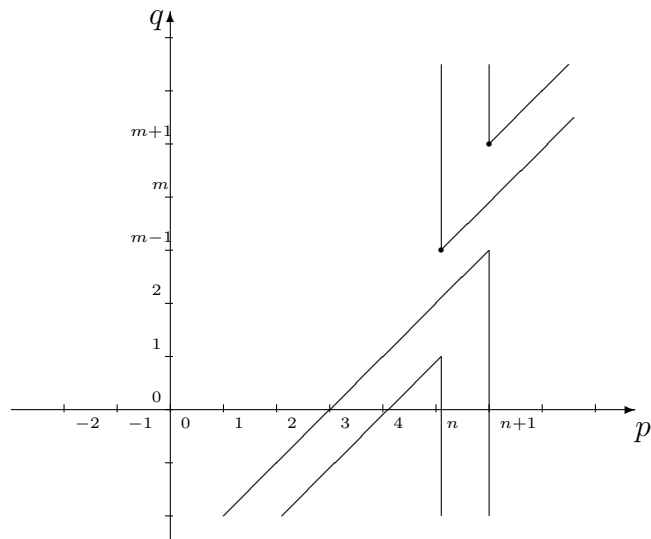

Fig. VII.3: The E_1 page of the cellular spectral sequence for $\mathbb{R}P^n$ for n even using flag symbol $(1, 2, \dots, a-1, n+1)$.

Also, for purely dimensional reasons, we must have that $d(a_{(n, \lceil \frac{n}{2} \rceil)}) = 0$. However, there is the potential for $d(a_{(n-1, \lceil \frac{n-1}{2} \rceil)})$ to be non zero.

Let $m = \lfloor \frac{n+1}{2} \rfloor$. Consider instead the flag symbol $(1, 2, \dots, m-1, n+1)$. With this flag symbol, the projective space has cells in dimensions $(n, m+1)$ and $(n-1, m-1)$. The picture of the E_1 term of this spectral sequence is in Figure VII.3. In this picture, only the contribution of the n and $n-1$ cells are depicted.

The differential leaving the $(n-1)$ -cell must be nonzero. This spectral sequence implies that the cohomology in degree $(n, n/2)$ must be nonzero. Thus the original spectral sequence has no nonzero differentials. \square

Lemma VII.4. *As a $H^{*,*}(pt)$ -module, $H^{*,*}(\mathbb{RP}_{tw}^\infty)$ is free with a single generator in dimension $(n, \lceil \frac{n}{2} \rceil)$, for all $n \in \mathbb{N}$.*

Proof. \mathbb{RP}_{tw}^∞ is the colimit of the above projective spaces. Thus, any non-zero differential for \mathbb{RP}_{tw}^∞ would induce a non-zero differential at some finite stage. This cannot be the case by the above argument. Hence, $H^{*,*}(\mathbb{RP}_{tw}^\infty)$ is a free $H^{*,*}(pt)$ -module with the specified generators. \square

Lemma VII.5. *As a $H^{*,*}(pt)$ -module, $H^{*,*}(S^{1,1})$ is free with a single generator in degree $(1, 1)$. As a ring, $H^{*,*}(S^{1,1}) \cong H^{*,*}(pt)[a]/(a^2 = \rho a)$.*

Proof. The statement about the module structure is immediate since $S^{1,1} \cong \mathbb{RP}_{tw}^1$.

Now, $S^{1,1}$ is a $K(\mathbb{Z}(1), 1)$, so we can consider $a \in [S^{1,1}, S^{1,1}]$ as the class of the identity and $\rho \in [pt, S^{1,1}]$ as the inclusion. Now a^2 is the composite

$$a^2: S^{1,1} \xrightarrow{\Delta} S^{1,1} \wedge S^{1,1} \xrightarrow{a \wedge a} S^{2,2} \longrightarrow K(\mathbb{Z}/2(2), 2).$$

Similarly, ρa is the composite

$$\rho a: S^{1,1} \longrightarrow S^{0,0} \wedge S^{1,1} \xrightarrow{\rho \wedge a} S^{2,2} \longrightarrow K(\mathbb{Z}/2(2), 2).$$

The claim is that these two maps are homotopic. Considering the spheres involved at one point compactifications of the corresponding representations, the map a^2 is

inclusion of $(\mathbb{R}^{1,1})^+$ as the diagonal in $(\mathbb{R}^{2,2})^+$ and ρa is inclusion of $(\mathbb{R}^{1,1})^+$ as the vertical axis. There is then an equivariant homotopy $H: (\mathbb{R}^{1,1})^+ \times I \rightarrow (\mathbb{R}^{2,2})^+$ between these two maps given by $H(x, t) = (tx, x)$. \square

With these lemmas, we are ready to compute $H^{*,*}(\mathbb{RP}_{tw}^\infty)$.

Proof of Theorem VII.1. By the above lemmas, it remains to compute the multiplicative structure of the cohomology ring. Let $R = H^{*,*}(\mathbb{RP}_{tw}^\infty)$. Denote by $a = a_{(1,1)}$, and $b = a_{(2,1)}$. Observing the forgetful long exact sequence, Lemma VI.2, we see that the forgetful map $\psi: R \rightarrow H_{sing}^*(\mathbb{RP}^\infty)$ maps $\psi(a) = z$ and $\psi(b) = z^2$ where $z \in H_{sing}^1(\mathbb{RP}^\infty)$ is the ring generator for singular cohomology. Since ψ is a homomorphism of rings, $\psi(ab) = z^3 \neq 0$, and so the product ab is nonzero in R . Observe that ρb is also in degree $(3, 2)$ in R , but $\psi(\rho b) = 0$ since $\psi(\rho) = 0$. Thus ab and ρb generate R in degree $(3, 2)$. Also, $\psi(b^2) = z^4$, and so b^2 is nonzero in R . This means that b^2 is the unique nonzero element of R in degree $(4, 2)$. Inductively, it can be shown that if n is even the unique nonzero element of R in degree $(n, \frac{n}{2})$ is $b^{n/2}$ and that if n is odd, then $ab^{(n-1)/2}$ is linearly independent from $\rho b^{(n-1)/2}$.

Now, $a^2 \in H^{2,2}(\mathbb{RP}_{tw}^\infty)$ and so is a linear combination of ρa and τb . Since $\psi(a^2) = z^2$, there must be a τb term in the expression for a^2 . Also, upon restriction to $\mathbb{RP}_{tw}^1 = S^{1,1}$, a^2 restricts to $a^2 = \rho a$. Thus, there must be a ρa term in the expression for a^2 . Thus, $a^2 = \rho a + \tau b \in R$.

This gives the multiplicative structure of R as described in the statement of the theorem. \square

We can also compute the cohomology of projective spaces associated to arbitrary representations. The following easy lemma will be useful. In particular, it allows us to only consider the projective spaces associated to representations $V \cong \mathbb{R}^{p,q}$ where $q \leq p/2$.

Lemma VII.6. $\mathbb{P}(\mathbb{R}^{p,q}) \cong \mathbb{P}(\mathbb{R}^{p,p-q})$.

Proof. Consider a basis of $\mathbb{R}^{p,q}$ in which the first q coordinates have the nontrivial action, and a basis of $\mathbb{R}^{p,p-q}$ in which the first q coordinates are fixed by the action. Then the map $f: \mathbb{P}(\mathbb{R}^{p,q}) \rightarrow \mathbb{P}(\mathbb{R}^{p,p-q})$ that sends the span of (x_1, \dots, x_p) to the span of (x_1, \dots, x_p) is equivariant. It is clearly a homeomorphism. \square

Lemma VII.7. *If $q \leq p/2$, then $\mathbb{P}(\mathbb{R}^{p,q})$ has a cell structure with a single cell in each dimension $(0, 0), (1, 1), (2, 1), (3, 2), (4, 2), \dots, (2q - 1, q), (2q, q), \dots, (p - 1, q)$.*

For example, $\mathbb{P}(\mathbb{R}^{4,1})$ has a single cell in each dimension $(0, 0), (1, 1), (2, 1)$, and $(3, 1)$.

Proof. The argument will be similar to the one above for $\mathbb{R}\mathbb{P}_{tw}^n$. One can decompose this representation as $\mathbb{R}^{p,q} = \mathbb{R}^{2q,q} \oplus \mathbb{R}^{p-2q,0}$. Now, with this decomposition, the $(2q - 1)$ -skeleton is obtained exactly as in Lemma 4.2. Next, consider the span of a line of the form $(x_1, \dots, x_q, x_{q+1}, \dots, x_{2q}, 1)$. The $\mathbb{Z}/2$ -action sends this to $(-x_1, \dots, -x_q, x_{q+1}, \dots, x_{2q}, 1)$, yielding a $(2q, q)$ -cell. Continuing to add cells in this way, each successive cell will have exactly q twists. \square

Lemma VII.8. *As a $H^{*,*}(pt)$ -module, $H^{*,*}(\mathbb{P}(\mathbb{R}^{p,q}))$ is free with a single generator in dimensions $(0, 0), (1, 1), (2, 1), (3, 2), (4, 2), \dots, (2q, q), (2q + 1, q), \dots, (p - 1, q)$.*

Proof. Fix q and proceed by induction on $p \geq q/2$. The base case is exactly Lemma 4.3 where $p = 2q$. For the inductive step, notice that $d(a_{p,q}) = 0$ for dimensional reasons. Again, by considering the flag symbol $(1, 2, \dots, q - 1, 2q)$, one sees that all differentials in the spectral sequence must be zero. \square

Next, we compute $H^{*,*}(\mathbb{P}(\mathbb{R}^n, \lfloor \frac{n}{2} \rfloor))$. For the case $n = 2$, we have $\mathbb{P}(\mathbb{R}^{2,1}) \cong S^{1,1}$ and so the result is Lemma 4.5 above.

Lemma VII.9. *Let $n > 2$. If n is even, then*

$H^{*,*}(\mathbb{P}(\mathbb{R}^n, \frac{n}{2})) = H^{*,*}(pt)[a_{1,1}, b_{2,1}]/\sim$ where the generating relations are

$a^2 = \rho a + \tau b$ and $b^k = 0$ for $k \geq \frac{n}{2}$. If n is odd, then

$H^{*,*}(\mathbb{P}(\mathbb{R}^n, \frac{n-1}{2})) = H^{*,*}(pt)[a_{1,1}, b_{2,1}]/\sim$ where the generating relations are

$a^2 = \rho a + \tau b$, $b^k = 0$ for $k \geq \frac{n+1}{2}$, and $a \cdot b^{(n-1)/2} = 0$.

Proof. Only the multiplicative structure needs to be checked since the cohomology is free and the generators given above are in the correct dimensions. Considering the restriction of the corresponding classes a and b in $H^{*,*}(\mathbb{R}\mathbb{P}_{tw}^\infty)$, the relation $a^2 = \rho a + \tau b$ is immediate. The relations $b^k = 0$ for $k > \frac{n}{2}$ when n is even and $b^k = 0$ for $k \geq \frac{n+1}{2}$ when n is odd follow for dimensional reasons. Also, since the class $ab \in H^{*,*}(\mathbb{R}\mathbb{P}_{tw}^\infty)$ is a free generator, it restricts to zero in $H^{*,*}(\mathbb{P}(\mathbb{R}^n, \frac{n-1}{2}))$. Thus $ab = 0 \in H^{*,*}(\mathbb{P}(\mathbb{R}^n, \frac{n-1}{2}))$. \square

The ring structure of the other projective spaces can be computed in a similar manner, by considering the restriction $H^{*,*}(\mathbb{R}\mathbb{P}_{tw}^\infty)$ to $H^{*,*}(\mathbb{P}(\mathbb{R}^{p,q}))$. For example, consider $\mathbb{P}(\mathbb{R}^{4,1})$. By the above lemmas, the cohomology of $\mathbb{P}(\mathbb{R}^{4,1})$ is free, generated by classes $a_{1,1}$, $b_{2,1}$, and $c_{3,1}$. The corresponding classes a and b in $H^{*,*}(\mathbb{R}\mathbb{P}_{tw}^\infty)$ restrict to the a and b here, so we automatically know that $a^2 = \rho a + \tau b$ in $H^{*,*}(\mathbb{P}(\mathbb{R}^{4,1}))$. Now, ab has degree $(3, 2)$ and so $ab = ?\rho b + ?\tau c$. However, the product ab in $H^{*,*}(\mathbb{R}\mathbb{P}_{tw}^\infty)$ restricts to the class τc . Since restriction is a map of rings, it must be that $ab = \tau c$ in $H^{*,*}(\mathbb{P}(\mathbb{R}^{4,1}))$. Similar considerations show that $bc = 0$ and $c^2 = 0$. Thus $H^{*,*}(\mathbb{P}(\mathbb{R}^{4,1})) = H^{*,*}(pt)[a_{1,1}, b_{2,1}, c_{3,1}]/\sim$, where the generating relations are $a^2 = \rho a + \tau b$, $ab = \tau c$, $bc = 0$, and $c^2 = 0$. Using similar arguments, one can compute the cohomology of the remainder of the

projective spaces. While an explicit description of the ring structure is complicated, this result can be summarized by the following proposition.

Proposition VII.10. $H^{*,*}(\mathbb{P}(\mathbb{R}^{p,q}))$ is a truncated polynomial algebra over $H^{*,*}(pt)$ on generators in dimensions $(1, 1)$, $(2, 1)$, $(2q + 1, q)$, $(2q + 2, q)$, \dots , $(p - 1, q)$, subject to the relations determined by the restriction of $H^{*,*}(\mathbb{R}\mathbb{P}_{tw}^\infty)$ to $H^{*,*}(\mathbb{P}(\mathbb{R}^{p,q}))$.

To end this section, let's highlight the connection of the structure of the $RO(\mathbb{Z}/2)$ -graded cohomology of real projective spaces with their singular cohomology. This will make explicit the use of the forgetful long exact sequence in the proof of Theorem VII.1. Letting $X = \mathbb{R}\mathbb{P}_{tw}^\infty$, we have the following exact sequence.

$$\begin{array}{ccccccc} \dots & \longrightarrow & H^{0,0}(X) & \xrightarrow{\cdot\rho} & H^{1,1}(X) & \xrightarrow{\psi} & H_{sing}^1(X) & \xrightarrow{\delta} & H^{1,0}(X) \\ & & & & & & \nearrow \cdot\rho & & \\ & & H^{2,1}(X) & \xleftarrow{\psi} & H_{sing}^2(X) & \xrightarrow{\delta} & 0 & & \end{array}$$

All groups above are taken with constant $\mathbb{Z}/2$ or $\underline{\mathbb{Z}/2}$ coefficients. The generators of these groups are given in the diagram below.

$$\begin{array}{ccccccc} \dots & \longrightarrow & \langle 1 \rangle & \xrightarrow{\cdot\rho} & \langle \rho, a \rangle & \xrightarrow{\psi} & \langle z \rangle & \xrightarrow{\delta} & 0 \\ & & & & & & \nearrow \cdot\rho & & \\ & & \langle b \rangle & \xleftarrow{\psi} & \langle z^2 \rangle & \xrightarrow{\delta} & 0 & & \end{array}$$

From this, it is evident that the forgetful map ψ takes a to z and b to z^2 . Since ψ is a map of rings, we now have that $\psi(a^n \cdot b^m) = z^{n+2m}$. Similar computations will yield that, in any of the finite projective spaces and for each n , the free generator in degree $(n, ?)$ maps to z^n under the forgetful map.

CHAPTER VIII

GRASSMANNIANS

The Grassmann manifold plays an important role in the theory of vector bundles. Let $G_n(\mathbb{R}^{p,q})$ denote the space of n -planes in $\mathbb{R}^{p,q}$ with action induced by that on $\mathbb{R}^{p,q}$.

The inclusions in the commutative diagram

$$\begin{array}{ccccccc}
 0 & \longrightarrow & \mathbb{R}^{1,0} & \longrightarrow & \mathbb{R}^{1,0} \oplus \mathbb{R}^{1,0} & \longrightarrow & \dots \\
 \downarrow & & \downarrow & & \downarrow & & \\
 \mathbb{R}^{1,1} & \longrightarrow & \mathbb{R}^{1,1} \oplus \mathbb{R}^{1,0} & \longrightarrow & \mathbb{R}^{1,1} \oplus \mathbb{R}^{1,0} \oplus \mathbb{R}^{1,0} & \longrightarrow & \dots \\
 \downarrow & & \downarrow & & \downarrow & & \\
 \mathbb{R}^{1,1} \oplus \mathbb{R}^{1,1} & \longrightarrow & \mathbb{R}^{1,1} \oplus \mathbb{R}^{1,1} \oplus \mathbb{R}^{1,0} & \longrightarrow & \mathbb{R}^{1,1} \oplus \mathbb{R}^{1,1} \oplus \mathbb{R}^{1,0} \oplus \mathbb{R}^{1,0} & \longrightarrow & \dots \\
 \downarrow & & \downarrow & & \downarrow & & \\
 \vdots & & \vdots & & \vdots & &
 \end{array}$$

(where trivial representations are always added on the right and nontrivial ones added on the left) give inclusions $G_n(\mathbb{R}^{p,q}) \subset G_n(\mathbb{R}^{p+1,q})$ and $G_n(\mathbb{R}^{p,q}) \subset G_n(\mathbb{R}^{p+1,q+1})$. The colimit of these inclusions is $G_n = G_n(\mathcal{U})$, the space of n -dimensional subspaces of \mathcal{U} . The action can be thought of as the one induced by the action on \mathcal{U} .

The usual Schubert cell decomposition endows the Grassmann manifolds

with a $\text{Rep}(\mathbb{Z}/2)$ -cell structure. However, the number of twists in each cell is dependent upon the flag of subrepresentations of $\mathbb{R}^{p,q}$ that is chosen. Consider $G_n(\mathbb{R}^{p,q})$. A sequence of integers $\varphi = (\varphi_1, \dots, \varphi_q)$ satisfying $1 \leq \varphi_1 < \dots < \varphi_q \leq q$ determines a flag of subrepresentations. A flag $V_0 = 0 \subset V_1 \subset \dots \subset V_p = \mathbb{R}^{p,q}$ determined by φ satisfies $V_{\varphi_i}/V_{\varphi_{i-1}} = \mathbb{R}^{1,1}$ for all $i = 1, \dots, q$, and all other quotients of consecutive terms are $\mathbb{R}^{1,0}$, and consists of a sequence of subspaces in which a coordinate basis vector is adjoined to get from one term to the next. Such a φ will be called a flag symbol. For example, there is a flag in $\mathbb{R}^{5,3}$ determined by the flag symbol $\varphi = (1, 3, 4)$ of the form $\mathbb{R}^{0,0} \subset \mathbb{R}^{1,1} \subset \mathbb{R}^{2,1} \subset \mathbb{R}^{3,2} \subset \mathbb{R}^{4,3} \subset \mathbb{R}^{5,3}$.

Let $\sigma = (\sigma_1, \dots, \sigma_n)$ be a Schubert symbol, in other words a sequence of integers such that $1 \leq \sigma_1 < \sigma_2 < \dots < \sigma_n \leq p$. Given a Schubert symbol σ and a flag symbol φ , let $e(\sigma, \varphi)$ be the set of planes $\ell \in G_n(\mathbb{R}^{p,q})$ for which $\dim(\ell \cap V_{\sigma_i}) = 1 + \dim(\ell \cap V_{\sigma_{i-1}})$, where $V_0 \subset \dots \subset V_n$ is the flag determined by φ . Then $e(\sigma, \varphi)$ is the interior of a cell $D(W)$ for some representation W . The dimension of the cell is determined by the Schubert symbol σ just as in nonequivariant topology, but the number of twists depends on both σ and the flag symbol φ .

For example, consider $G_2(\mathbb{R}^{5,3})$, $\sigma = (3, 5)$, and $\varphi = (1, 3, 4)$. Then $e(\sigma, \varphi)$ consists of planes ℓ which have a basis with echelon form given by the matrix below.

$$\begin{array}{ccccc} - & + & - & - & + \\ \left(\begin{array}{ccccc} * & * & 1 & 0 & 0 \\ * & * & 0 & * & 1 \end{array} \right) \end{array}$$

Here, the action of $\mathbb{Z}/2$ on the columns, as determined by φ , has been

indicated by inserting the appropriate signs above the matrix. After acting, this becomes the following.

$$\begin{array}{ccccc} & - & + & - & - & + \\ \left(\begin{array}{ccccc} - * & * & -1 & 0 & 0 \\ - * & * & 0 & - * & 1 \end{array} \right) \end{array}$$

Since we require the last nonzero entry of each row to be 1, we must scale the first row by -1 .

$$\begin{array}{ccccc} & - & + & - & - & + \\ \left(\begin{array}{ccccc} * & - * & 1 & 0 & 0 \\ - * & * & 0 & - * & 1 \end{array} \right) \end{array}$$

Since we have five coordinates which can be any real numbers, three of which the $\mathbb{Z}/2$ action of multiplication by -1 , this cell is a $(5, 3)$ -cell. Through a similar process, we can obtain a cell structure for $G_n(\mathbb{R}^{p,q})$ given any flag φ . The type of cell determined by the Schubert symbol σ and the flag φ is given by the following proposition. Here, $\underline{\sigma}_i = \{1, \dots, \sigma_i\}$ and $\sigma(i) = \{\sigma_1, \dots, \sigma_i\}$.

Proposition VIII.1. *Let $\sigma = (\sigma_1, \dots, \sigma_n)$ be a Schubert symbol and $\varphi = (\varphi_1, \dots, \varphi_q)$ be a flag symbol for $\mathbb{R}^{p,q}$. The cell $e(\sigma, \varphi)$ of $G_n(\mathbb{R}^{p,q})$ is of dimension (a, b) where $a = \sum_{i=1}^n (\sigma_i - i)$ and $b = \sum_{\sigma_i \in \varphi} |\underline{\sigma}_i \setminus (\varphi \cup \sigma(i))| + \sum_{\sigma_i \notin \varphi} |(\underline{\sigma}_i \cap \varphi) \setminus \sigma(i)|$.*

Proof. The formula for a is exactly the same as in the nonequivariant case. The one for b follows since the number of twisted coordinates in each row is exactly the number of $*$ coordinates for which the action is opposite to that on the coordinate containing the 1 in that echelon row. \square

With these Schubert cell structures, the spectral sequence of the filtration can sometimes be used to determine the cohomology of certain Grassmannians. It is important to recall that all differentials in this spectral sequence have degree $(1, 0)$ and they reach further up the filtration as you go from page to page. As an example, consider the space $X = G_2(\mathbb{R}^{4,1})$. Then by considering the flag $\varphi_1 = (4)$, X has a cell structure with cells of dimension $(0, 0)$, $(1, 0)$, $(2, 2)$, $(2, 0)$, $(3, 2)$, and $(4, 2)$. The E_1 term of the spectral sequence of the filtration associated to this cell structure is in Figure VIII.1 below.

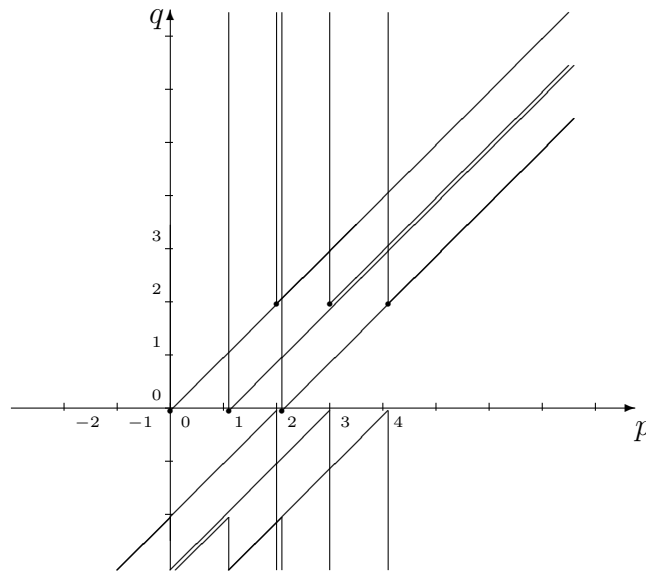

Fig. VIII.1: The E_1 term of the spectral sequence of the filtration of $G_2(\mathbb{R}^{4,1})$ with $\varphi_1 = (4)$.

If instead we had chosen the flag symbol $\varphi_2 = (3)$, the cell structure would have cells of dimension $(0, 0)$, $(1, 1)$, $(2, 1)$, $(2, 1)$, $(3, 1)$, and $(4, 2)$. The E_1 term of the spectral sequence for the filtration of this cell structure is in Figure VIII.2 below.

From this second picture, we can actually determine the

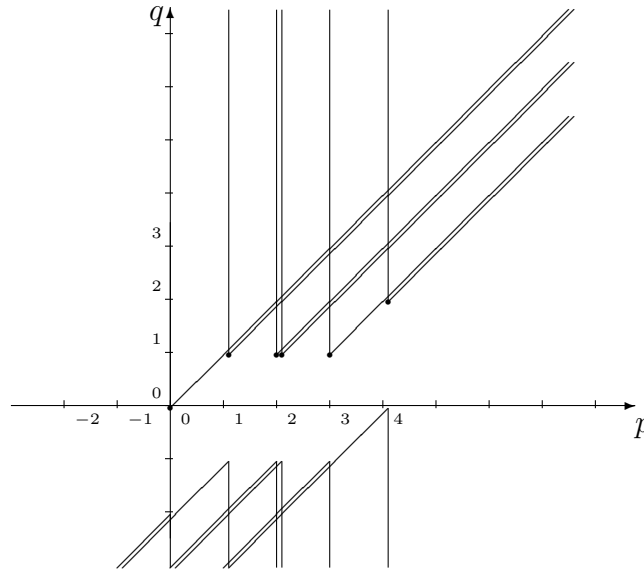

Fig. VIII.2: The E_1 term of the spectral sequence of the filtration of $G_2(\mathbb{R}^{4,1})$ with $\varphi_2 = (3)$.

$H^{*,*}(pt; \mathbb{Z}/2)$ -module structure of $H^{*,*}(G_2(\mathbb{R}^{4,1}); \mathbb{Z}/2)$. Applying the forgetful long exact sequence VI.2 to $X = G_2(\mathbb{R}^{4,1})$ and taking $q = 0$ yields the sequence below.

$$\cdots \longrightarrow H^{1,0}(X) \xrightarrow{\rho} H^{2,1}(X) \xrightarrow{\psi} H_{sing}^2(X) \xrightarrow{\delta} H^{2,0}(X) \longrightarrow \cdots$$

The second spectral sequence tells us that $H^{1,0}(X) = H^{2,0}(X) = 0$, and so the forgetful map ψ is an isomorphism. Since $H_{sing}^2(X) = \mathbb{Z}/2 \oplus \mathbb{Z}/2$, both of the $(2, 1)$ -cells must determine cohomology classes. Since all of the differentials in the spectral sequence of the filtration have degree $(1, 0)$, all differentials leaving the $(1, 1)$ -cell must be zero and the $(4, 2)$ -cell determines a free generator in cohomology. Thus all differentials are zero, and Figure VIII.2 displays the cohomology of $G_2(\mathbb{R}^{4,1})$. This is summarized by the following proposition.

Proposition VIII.2. $H^{*,*}(G_2(\mathbb{R}^{4,1}); \mathbb{Z}/2)$ is a free $H^{*,*}(pt; \mathbb{Z}/2)$ -module with generators in dimensions $(0, 0)$, $(1, 1)$, $(2, 1)$, $(2, 1)$, $(3, 1)$, and $(4, 2)$.

Now, this result was obtained from the second choice of flag symbols where the dimensions of the free generators is the same as the dimensions of the cells, but it should also follow from the first choice of flag symbols. In that case, the dimensions of the cells do not line up with the dimensions of the free generators, but they are still in bijective correspondence. This phenomenon is similar to the one observed by Ferland and Lewis in their book [9].

A similar type of calculation using the flag symbols $\varphi_1 = (4)$ and $\varphi_2 = (3)$ will yield the cohomology of $G_2(\mathbb{R}^{5,1})$.

Proposition VIII.3. $H^{*,*}(G_2(\mathbb{R}^{5,1}); \underline{\mathbb{Z}/2})$ is a free $H^{*,*}(pt; \underline{\mathbb{Z}/2})$ -module with generators in dimensions $(0, 0)$, $(1, 1)$, $(2, 1)$, $(2, 1)$, $(3, 1)$, $(3, 1)$, $(4, 1)$, $(4, 2)$, $(5, 2)$, and $(6, 2)$.

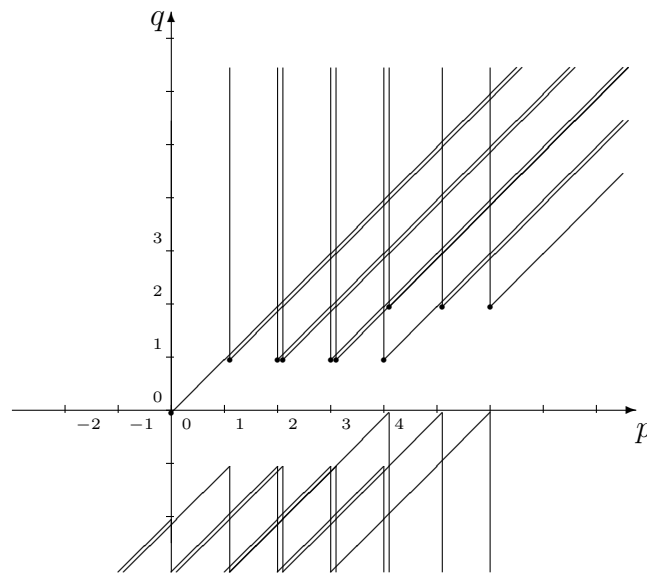

Fig. VIII.3: $H^{*,*}(G_2(\mathbb{R}^{5,1}))$

It should be noted that since by extending from $\mathbb{R}^{4,1}$ to $\mathbb{R}^{5,1}$ no twistings were added, there is a cellular inclusion from $G_2(\mathbb{R}^{4,1}) \hookrightarrow G_2(\mathbb{R}^{5,1})$ using the cell

structures coming from the flag symbol $\varphi_2 = (3)$. This is an example of a more general trend.

Proposition VIII.4. *If $V \subseteq V'$ is an inclusion of representations and $\varphi \subseteq \varphi'$ is an extension of flag symbols for V and V' , then there is a cellular inclusion $G_n(V) \hookrightarrow G_n(V')$.*

So far, the fact that the cohomology of these Grassmannians is free comes from ad hoc arguments like the ones above. As another example, consider now $X = G_2(\mathbb{R}^{4,2})$. Consider the three flag symbols $\varphi_1 = (2, 3)$, $\varphi_2 = (2, 4)$, and $\varphi_3 = (3, 4)$. The respective spectral sequences associated to the cell structures with these flag symbols have E_1 term given in Figures VIII.4, VIII.5, and VIII.6 below.

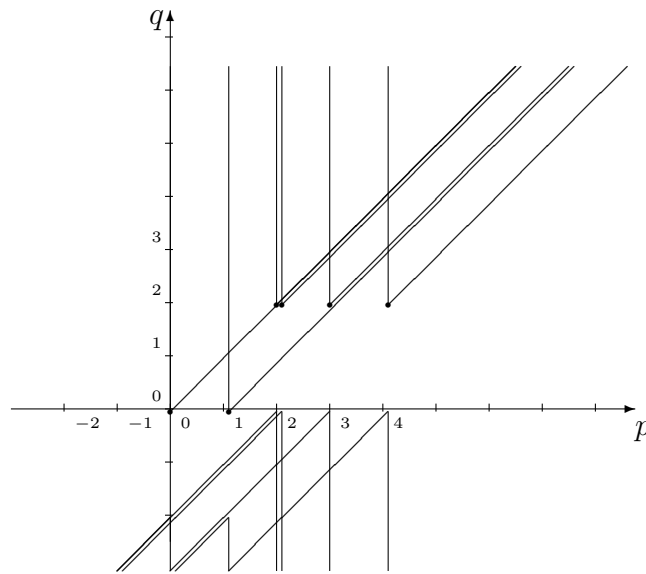

Fig. VIII.4: The E_1 page of the cellular spectral sequence for $G_2(\mathbb{R}^{4,2})$ using $\varphi_1 = (2, 3)$.

In the picture for φ_2 , $H^{1,0}(X) = 0$, and so the differential leaving the $(1, 0)$ generator in the φ_1 spectral sequence must be non-zero. Thus, $H^{1,1}(X) = \mathbb{Z}/2$, $H^{2,1}(X) = \mathbb{Z}/2$ and $H^{2,0}(X) = \mathbb{Z}/2$. In particular, there must be a free generator

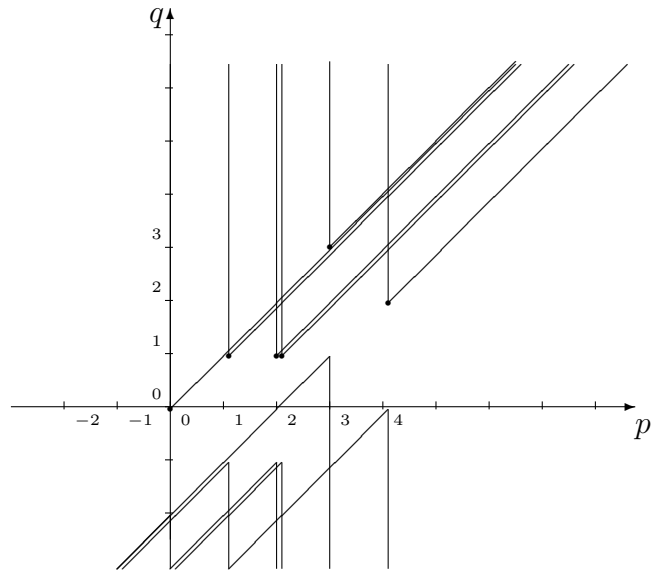

Fig. VIII.5: The E_1 page of the cellular spectral sequence for $G_2(\mathbb{R}^{4,2})$ using $\varphi_2 = (2, 4)$.

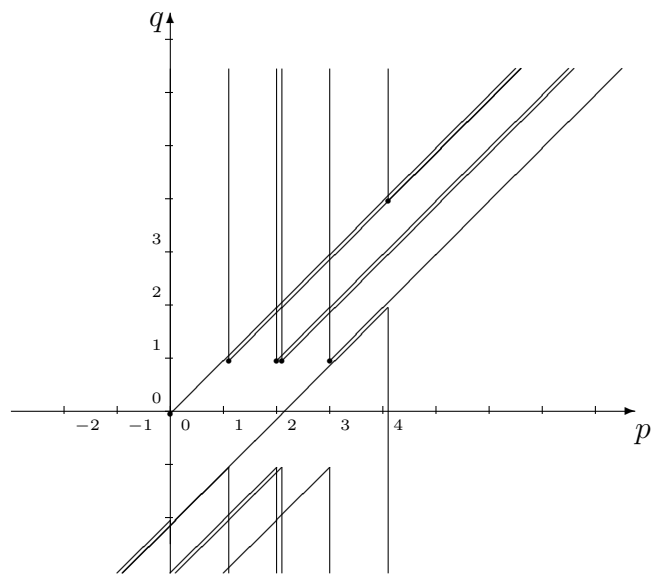

Fig. VIII.6: The E_1 page of the cellular spectral sequence for $G_2(\mathbb{R}^{4,2})$ using $\varphi_3 = (3, 4)$.

in degree $(1, 1)$ and there is a nontrivial differential leaving the $(2, 1)$ generators of the spectral sequence for φ_2 . After a change of basis, if necessary, the differential can be adjusted so that it is zero on one of the $(2, 1)$ generators and the other generator maps nontrivially. Now from φ_1 we see that $H^{4,1}(X) = 0$, and so there must be a nontrivial differential leaving the $(3, 1)$ generator in the φ_3 spectral sequence. This means that the $(4, 2)$ generator in the φ_1 and φ_2 spectral sequences must survive. Thus, all differentials in the φ_2 spectral sequence are known. They are all zero, except for the one leaving the two $(2, 1)$ generators, which behaves as described above. That spectral sequence collapses almost immediately to give the following picture of the cohomology of $G_2(\mathbb{R}^{4,2})$.

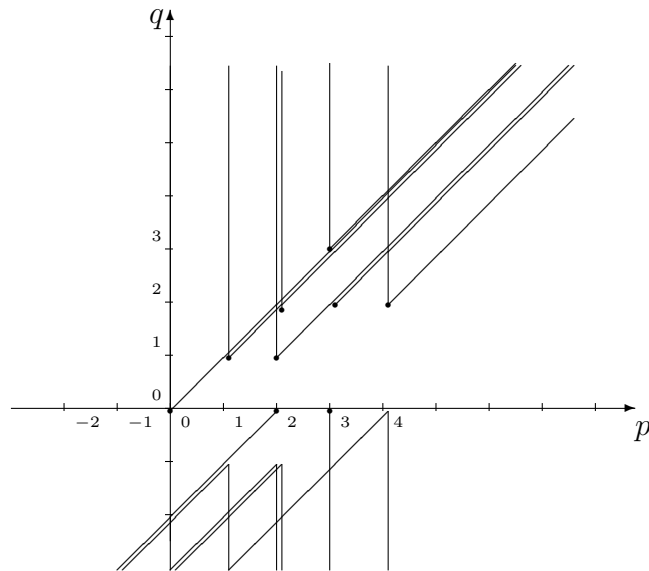

Fig. VIII.7: $H^{*,*}(G_2(\mathbb{R}^{4,2}))$

From this picture, it is not clear whether $H^{*,*}(G_2(\mathbb{R}^{4,2}))$ is free or not. However, counting the $\mathbb{Z}/2$ dimensions in each bidegree reveals that the dimensions are the same as those of a free $H^{*,*}(pt)$ -module with generators in dimension $(1, 1)$, $(2, 1)$, $(2, 2)$, $(3, 2)$, and $(4, 2)$. In fact, by Theorem VI.5, we know

that $H^{*,*}(G_2(\mathbb{R}^{4,2}))$ must be free. Thus we have the following computation.

Proposition VIII.5. $H^{*,*}(G_2(\mathbb{R}^{4,2}))$ is a free $H^{*,*}(pt)$ -module with generators in dimension $(1, 1)$, $(2, 1)$, $(2, 2)$, $(3, 2)$, and $(4, 2)$.

That is, $H^{*,*}(G_2(\mathbb{R}^{4,2}))$ has free generators as displayed in Figure VIII.8.

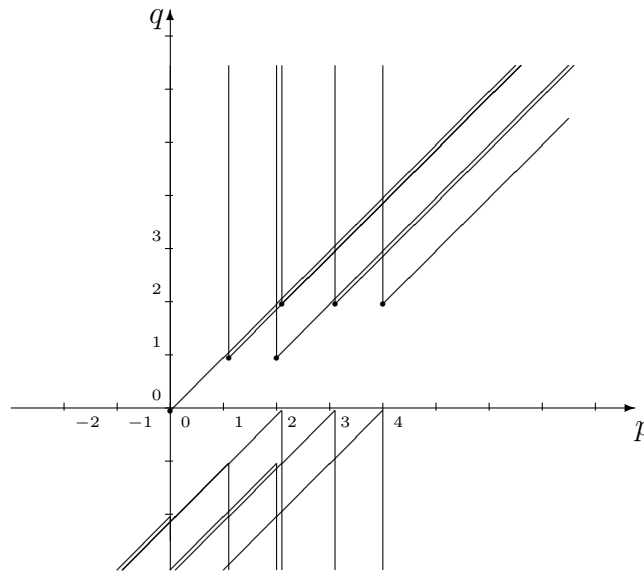

Fig. VIII.8: $H^{*,*}(G_2(\mathbb{R}^{4,2}))$ with free generators shown.

Remark VIII.6. It should be noted that in the case of $G_2(\mathbb{R}^{4,1})$, one of the cell structures was such that the differentials were all zero, and so the cohomology was free with generators in the same dimensions as the cells, at least after the proper choice of flag symbols. This is **not** the case with $G_2(\mathbb{R}^{4,2})$. Regardless of the choice of flag symbol, there must be some nonzero differentials. However, the cohomology should still be free, but with generators in degrees different than those of the cells. This suggests that there is some sort of dimension shifting, similar to those observed in [9] with cell complexes built of “even” dimensional cells.

In some special cases, we can deduce the additive structure of the cohomology of certain Grassmann manifolds without playing different cell structures off of each other like was done above. Instead, we can appeal to the freeness theorem.

Proposition VIII.7. *$H^{*,*}(G_n(\mathbb{R}^{u,v}))$ is a free $H^{*,*}(pt)$ -module with generators in bijective correspondence with the Schubert cells.*

Proof. Since $G_n(\mathbb{R}^{u,v})$ has a $\text{Rep}(G)$ -complex structure, it must be that $H^{*,*}(G_n(\mathbb{R}^{u,v}))$ is free by the freeness theorem, Theorem VI.5. Let $\{\omega_1, \dots, \omega_k\}$ be a set of free generators. Then $k \leq m$ where m is the number of Schubert cells.

These spaces are based, so we can appeal to the forgetful long exact sequence Lemma VI.2. As a consequence of freeness, the map $\cdot\rho: H^{*,q}(G_n(\mathbb{R}^{u,v})) \rightarrow H^{*+1,q+1}(G_n(\mathbb{R}^{u,v}))$ is an injection for large enough q . Thus the forgetful map to singular cohomology is surjective. Since $H_{sing}^*(G_n(\mathbb{R}^{u,v}))$ is free with generators a_1, \dots, a_m in bijective correspondence with the Schubert cells, $H^{*,*}(G_n(\mathbb{R}^{u,v}))$ has a set of elements, $\{\alpha_1, \dots, \alpha_m\}$, with $\psi(\alpha_i) = a_i$. We can uniquely express each α_i as $\alpha_i = \sum_{j=1}^k \rho^{e_{ij}} \tau^{f_{ij}} \omega_j$. We can ignore any terms that have ρ in them since $\psi(\rho) = 0$. This gives a new set of elements, $\bar{\alpha}_i = \sum_{j=1}^k \epsilon_{ij} \tau^{f_{ij}} \omega_j$, where $\epsilon_{ij} = 0$ or 1 and $\psi(\bar{\alpha}_i) = a_i$. Since $\psi(\tau) = 1$, we have that $\sum_{j=1}^k \epsilon_{ij} \psi(\omega_j) = a_i$. Since linear combinations of the linearly independent ω_j 's map to the linearly independent a_i 's, there must be at least as many ω_j 's as there are a_i 's. That is, $k \geq m$. □

As was seen above, the free generators may be in degrees different than those of the cells. However, knowing the number of generators in each dimension can allow us to deduce the additive structure of the cohomology of some Grassmann manifolds.

Consider again $G_2(\mathbb{R}^{5,1})$. Using the Schubert cell structure coming from the flag symbol $\varphi = (2)$, (or equivalently $\varphi = (3)$), we get the picture of the E_1 term of the cellular spectral sequence as shown in Figure VIII.9.

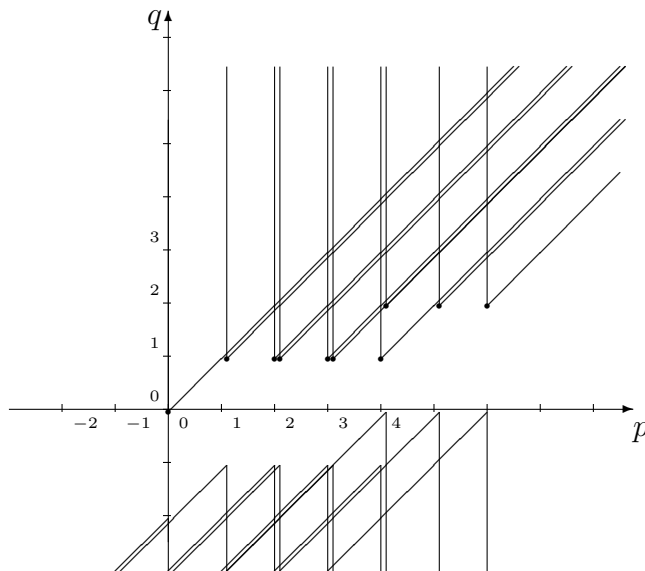

Fig. VIII.9: The cellular spectral sequence for $G_2(\mathbb{R}^{5,1})$ using $\varphi = 3$.

Any nonzero differentials would completely kill at least one of the free generators. Since the cohomology generators are in bijection with the cells, there can be no nonzero differentials. Thus, this cell structure gives the additive cohomology structure exactly.

A similar argument for $G_2(\mathbb{R}^{6,1})$ using the Schubert cell structure coming from the flag symbol $\varphi = (2)$ gives the additive structure of $H^{*,*}(G_2(\mathbb{R}^{6,1}))$. This is recorded in Figure VIII.10 below.

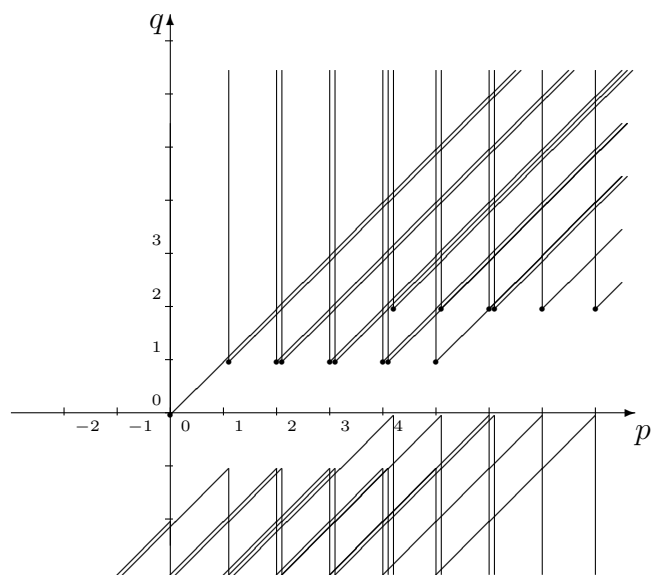

Fig. VIII.10: $H^{*,*}(G_2(\mathbb{R}^{6,1}))$

CHAPTER IX

EQUIVARIANT ADAMS-HILTON CONSTRUCTION

This section provides a G -representation complex structure to the space of Moore loops of a G -representation space Y under certain assumptions on the types of cells involved.

Let $(Y, *)$ be a based G -space. Let $\Omega^M(Y, *) \subseteq \text{Map}([0, \infty), X) \times [0, \infty)$ denote the subspace of all pairs (φ, r) for which $\varphi(0) = *$ and $\varphi(t) = *$ for $t \geq r$. The space $\Omega^M(Y, *)$ is the space of Moore loops of Y . It inherits a G -action given by $g \cdot (\varphi, r) = (g \cdot \varphi, r)$, where $(g \cdot \varphi)(t) = g \cdot \varphi(t)$. (The action of G on both \mathbb{R} and $[0, \infty)$ are assumed to be trivial, so this is the usual diagonal action of G on a product restricted to the subspace of Moore loops.)

Proposition IX.1. $\Omega(Y, *)$ is a G -deformation retract of $\Omega^M(Y, *)$.

Proof. The argument from nonequivariant topology adapts effortlessly to the equivariant setting. What follows is essentially the argument from Proposition 5.1.1 of [15].

First consider $\tilde{\Omega}(Y, *) \subseteq \Omega^M(Y, *)$, the subspace of all (φ, t) with $t \geq 1$. A deformation retraction, H , of $\Omega^M(Y, *)$ onto $\tilde{\Omega}(Y, *)$ is given by the following formulae:

$$H(s, (\varphi, r)) = (\varphi, r + s) \text{ when } r + s \leq 1$$

$$H(s, (\varphi, r)) = (\varphi, 1) \text{ when } r \leq 1 \text{ and } r + s \geq 1$$

$$H(s, (\varphi, r)) = (\varphi, r) \text{ when } r \geq 1$$

Now a deformation retraction K from $\tilde{\Omega}(Y, *)$ to $\Omega(Y, *)$ is given by the formula

$$K(s, (\varphi, r)) = (\varphi_s, (1 - s)r + s),$$

where $\varphi_s(t) = \varphi(\frac{r}{(1-s)r+s}t)$.

Notice that H and K are both equivariant deformation retractions.

□

Given any based G -space $(X, *)$, one can form the free G -monoid $M(X, *)$ just as in the nonequivariant setting. As a space, $M(X, *) = \coprod X^n / \sim$. Here, \sim is the equivalence relation generated by all the relations of the form

$$(x_1, \dots, x_{i-1}, *, x_{i+1}, \dots, x_n) \sim (x_1, \dots, x_{i-1}, x_{i+1}, \dots, x_n).$$

The G -action on $M(X, *)$ is inherited from the diagonal action of G on each of the products X^n . Note that since the basepoint $*$ is fixed by G , this action factors through the relation \sim .

This free G -monoid on $(X, *)$ enjoys the universal property that any based G -map $f: X \rightarrow M$, where M is any topological G -monoid with $f(*) = e$, can be extended uniquely to a G -map $\tilde{f}: M(X, *) \rightarrow M$.

$\Omega^M(Y, *)$ is a topological G -monoid. The loop concatenation product respects the G action in the sense that $g \cdot ((\varphi, r) * (\psi, s)) = ((g \cdot \varphi) * (g \cdot \psi), r + s)$. The point $(*, 0)$, where $*$ denotes the constant loop at the base point of Y , is the identity element.

Let $(X, *)$ be a based G -space. The equivariant James map is the G -map $J: (X, *) \rightarrow (\Omega \Sigma X, *)$ given by $J(x)(t) = [t, x] \in \Sigma X$. Here, the G -action is given

by $(g \cdot J(x))(t) = [t, g \cdot x]$. Compose this G -map with the inclusion of $\Omega\Sigma X$ into $\Omega^M\Sigma X$ to obtain a G -map $J: (X, *) \rightarrow (\Omega^M\Sigma X, *)$ that does not carry the base point to the identity. Let $\hat{X} = X \coprod [0, 1]/(1 \sim *)$ and define an extension \hat{J} of J to \hat{X} by $\hat{J}(s) = (*, s)$ for $s \in [0, 1]$ where $*$ denotes the constant path at the basepoint. Note that \hat{X} and X are based G -homotopy equivalent if X is a G -CW complex. By now considering 0 to be the basepoint of \hat{X} , \hat{J} is now a based G -map. This now extends uniquely to a G -map $\bar{J}: M(\hat{X}, 0) \rightarrow \Omega^M\Sigma X$. This is the map in James' theorem.

James' Theorem states that if X is a connected CW complex, the map $\bar{J}: M(\hat{X}, 0) \rightarrow \Omega^M\Sigma X$ is a homotopy equivalence. See [3] for a proof of James' theorem. This can be easily extended to the equivariant setting in the case that X has connected fixed sets.

Theorem IX.2 (Equivariant James Theorem). *If X is a connected G -CW complex with X^H connected for all $H \leq G$, the G -map $\bar{J}: M(\hat{X}, 0) \rightarrow \Omega^M\Sigma X$ is a G -homotopy equivalence.*

Proof. Observe that $M(\hat{X}, 0)^H = M(\hat{X}^H, 0)$ and $(\Omega^M\Sigma X)^H = \Omega^M\Sigma(X^H)$. Now, $\bar{J}^H: M(\hat{X}, 0)^H \rightarrow (\Omega^M\Sigma X)^H$ is a homotopy equivalence by James' theorem since X^H is a connected CW complex by assumption. Thus \bar{J} is a G -homotopy equivalence. □

The space $J(X) = M(\hat{X}, 0)$ is called the James construction. $J(X)$ is a free, associative, unital G -monoid. If the basepoint $*$ of X is a vertex, then $J(X)$ has a natural G -CW complex structure coming from the decomposition of X^n as a product G -CW complex. Thus $J(X)$ has the following properties:

1. every element $v \in J(X)$ has a unique expression $v = *$ or $v = x_1x_2 \cdots x_n$,
 $x_i \in X \setminus *$ for $1 \leq i \leq n$.
2. $x_1 \cdots x_n$ is contained in a unique cell of $J(X)$, the cell $C_1 \times \cdots \times C_n$ where
 $x_i \in \text{Int}(C_i)$, $1 \leq i \leq n$, so that no indecomposable cell contains
decomposable points, and
3. non-equivariantly, the cell complex has the form of a tensor algebra
 $T(C_{\#}(X))$, where the sub complex $C_{\#}(X)$ is exactly the indecomposables,
and the generating cells in dimension i are in bijective correspondence with
the cells in dimension $i + 1$ of ΣX .

Nonequivariantly, we have the Adams-Hilton construction as follows. Let Y be a CW complex with a single vertex $*$ and no 1-cells. Then there is a model for $\Omega^M(Y)$ which is a free associative monoid, with $*$ the only vertex, the generating cells in dimension i are in 1-1 correspondence with the $(i + 1)$ -dimensional cells of Y , and it satisfies (2) above. This will generalize to the following equivariant version.

Theorem IX.3 (Equivariant Adams-Hilton). *Let Y be a $\text{Rep}(G)$ -complex with a single vertex $*$, no 1-cells, and the only cells in higher dimensions are $V \oplus 1$ -cells where V is a real representation of G with all fixed sets of S^V connected. Then there is a model for $\Omega^M(Y)$ which is a free associative monoid, with $*$ the only vertex, the generating cells in dimension V are in 1-1 correspondence with the $(V \oplus 1)$ -dimensional cells of Y , and it satisfies (2) above.*

For the case $G = \mathbb{Z}/2$ the theorem becomes the following.

Theorem IX.4 ($\mathbb{Z}/2$ -Equivariant Adams-Hilton). *Let Y be a $\text{Rep}(\mathbb{Z}/2)$ -complex with a single vertex $*$ and no (n, n) -cells or $(n, n - 1)$ -cells for $n \geq 1$. Then there is a model for $\Omega^M(Y)$ which is a free associative monoid, with $*$ the only vertex, the generating cells in dimension (p, q) are in 1-1 correspondence with the $(p + 1, q)$ -dimensional cells of Y , and it satisfies (2) above.*

With these restrictions on the types of cells in our $\text{Rep}(G)$ -complex, the proof of the Adams-Hilton theorem in [3] adapts to the equivariant case. For example, in the base case of the inductive argument, one has that the 2-skeleton $Y^{(2)} = \bigvee_{V_\alpha} S^{V_\alpha \oplus 1} = \Sigma^1(\bigvee_{V_\alpha} S^{V_\alpha})$. Since each S^{V_α} has connected fixed sets, the equivariant James construction applies and the result is immediate.

For the inductive step, the prolongation construction and quasifibered arguments are already equivariant. This allows the remainder of the argument to adapt to the equivariant setting.

One application of this model is the computation of $H^{*,*}(\Omega S^{p,q}; \underline{\mathbb{Z}/2})$ when $S^{p,q}$ has a connected fixed set and $p \geq 2$.

Proposition IX.5. *If $S^{p,q}$ is equivariantly 1-connected, then $H^{*,*}(\Omega S^{p,q}; \underline{\mathbb{Z}/2})$ is an exterior algebra over $H^{*,*}(pt; \underline{\mathbb{Z}/2})$ on generators a_1, a_2, \dots , where $a_i \in H^{(p-1) \cdot 2^{i-1}, q \cdot 2^{i-1}}(\Omega S^{p,q}; \underline{\mathbb{Z}/2})$.*

Sketch of proof. For each value of p and q , the argument is similar, so let's focus on the case $p = 4$ and $q = 2$ to compute $H^{*,*}(\Omega S^{4,2})$.

Now, since the fixed set of $S^{4,2}$ is connected, by the Adams-Hilton construction we have an upperbound for the cohomology of the loop space given in Figure IX.1.

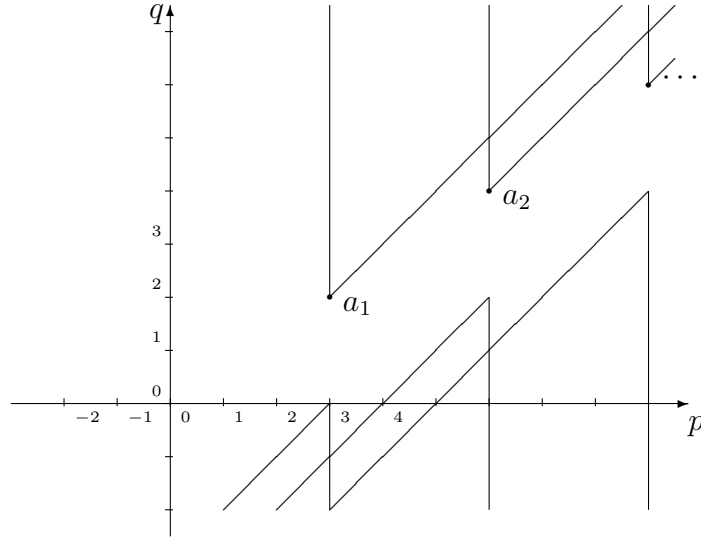

Fig. IX.1: The E_1 page of the cellular spectral sequence for $\Omega S^{4,2}$.

In the spectral sequence of the filtration, it is clear that all differentials must be zero, and so Figure IX.1 reveals the structure of $H^{*,*}(\Omega S^{4,2})$ as a free $H^{*,*}(pt)$ -module. Denote the generators of $H^{3 \cdot 2^{i-1}, 2 \cdot 2^{i-1}}(\Omega S^{p,q}; \underline{\mathbb{Z}/2})$ by a_i .

Consider the path-loop fibration $\Omega S^{4,2} \rightarrow PS^{4,2} \rightarrow S^{4,2}$. The base is 1-connected, so we can apply the spectral sequence of Theorem III.6, which will converge to the cohomology of a point since the total space $PS^{4,2} \simeq pt$. Consider first the $r = 2$ portion of the spectral sequence.

To fill in the entries in the spectral sequence, the Mackey functors $\underline{H}^{q,2}(\Omega S^{4,2})$ need to be computed for various values of q . These can be obtained from the module structure above. The calculations yield that

$\underline{H}^{0,2}(\Omega S^{4,2}) = \underline{H}^{3,2}(\Omega S^{4,2}) = \underline{\mathbb{Z}/2}$, $\underline{H}^{1,2}(\Omega S^{4,2}) = \underline{H}^{2,2}(\Omega S^{4,2}) = \langle \underline{\mathbb{Z}/2} \rangle$, and $\underline{H}^{4,2}(\Omega S^{4,2}) = \underline{H}^{5,2}(\Omega S^{4,2}) = 0$. The Mackey functor $\underline{H}^{6,2}(\Omega S^{4,2})$ is dual to $\underline{\mathbb{Z}/2}$, though this information will not be needed.

Given the above Mackey functors, we have that the $q = 0$ and $q = 3$ rows

are $H^{*,0}(S^{4,2}; \mathbb{Z}/2)$, the $q = 1$ and $q = 2$ rows are $H_{sing}^*(S^2; \mathbb{Z}/2)$, and the $q = 4$ and $q = 5$ rows are entirely zeroes. Thus the spectral sequence is as shown in Figure IX.2.

$q \uparrow$						
6	??	??	??	??	??	??
5	0	0	0	0	0	0
4	0	0	0	0	0	0
3	$\mathbb{Z}/2$	0	0	0	$\mathbb{Z}/2$	0
2	$\mathbb{Z}/2$	0	$\mathbb{Z}/2$	0	0	0
1	$\mathbb{Z}/2$	0	$\mathbb{Z}/2$	0	0	0
0	$\mathbb{Z}/2$	0	0	0	$\mathbb{Z}/2$	0
	0	1	2	3	4	$p \rightarrow$

Fig. IX.2: The $r = 2$ spectral sequence for $\Omega S^{4,2} \rightarrow PS^{4,2} \rightarrow S^{4,2}$.

Since the total space of the fibration is contractible, the spectral sequence converges to $H^{p+q,2}(pt)$. Since $H^{4,2}(pt) = 0$, there must be a nontrivial differential $d_2: E^{0,3} \rightarrow E^{2,2}$ sending the generator $a_1 \in H^{0,0}(S^{4,2}; \underline{H}^{3,2}(\Omega S^{4,2}))$ to the generator $z \in H^{2,0}(S^{4,2}; \underline{H}^{2,2}(\Omega S^{4,2}))$.

Now, the products a_1^2 and $a \cdot z$ live in the $r = 4$ spectral sequence and so to determine the differentials on a_1^2 , we need the picture of that spectral sequence. This is shown in Figure IX.3.

Since $H^{7,4}(pt) = 0$, there must be a nontrivial differential $d_2: E^{0,6} \rightarrow E^{2,5}$ sending the generator a_2 isomorphically to $a \cdot z$. Since $d_2(a_1^2) = 0$, it must be that $a_1^2 = 0$. An inductive argument will show that the ring structure is indeed that of an exterior algebra with the specified generators. \square

$q \uparrow$						
6	$\mathbb{Z}/2$	0	0	0	$\mathbb{Z}/2$	0
5	$\mathbb{Z}/2$	0	$\mathbb{Z}/2$	0	0	0
4	$(\mathbb{Z}/2)^2$	0	$(\mathbb{Z}/2)^2$	0	0	0
3	$(\mathbb{Z}/2)^2$	0	$\mathbb{Z}/2$	0	$\mathbb{Z}/2$	0
2	$\mathbb{Z}/2$	0	$\mathbb{Z}/2$	0	0	0
1	$\mathbb{Z}/2$	0	$\mathbb{Z}/2$	0	0	0
0	$\mathbb{Z}/2$	0	0	0	$\mathbb{Z}/2$	0
	0	1	2	3	4	$p \rightarrow$

Fig. IX.3: The $r = 4$ spectral sequence for $\Omega S^{4,2} \rightarrow PS^{4,2} \rightarrow S^{4,2}$.

CHAPTER X

EQUIVARIANT LERAY-HIRSCH THEOREM

In this section, the familiar Leray-Hirsch Theorem is adapted for use in the equivariant setting. This will be useful for advancing a theory of equivariant characteristic classes.

Theorem X.1 (Equivariant Leray-Hirsch). *Let B be a based $\mathbb{Z}/2$ -CW complex with zero skeleton contains only trivial orbits. Let $F \xrightarrow{i} E \xrightarrow{p} B$ be a $\mathbb{Z}/2$ -fiber bundle with fiber F over each point in the 0-skeleton of B . Suppose that for some ring Mackey Functor M the following conditions are satisfied:*

1. $H^{*,*}(F; M)$ is a finitely generated free $H^{*,*}(pt; M)$ -module, and
2. there exist classes $c_j \in H^{*,*}(E; M)$ whose restrictions $i^*(c_j)$ form a basis for $H^{*,*}(F; M)$ in the fiber F over each point in the 0-skeleton of B .

Then the map $\Phi: H^{*,*}(B; M) \otimes_{H^{*,*}(pt; M)} H^{*,*}(F; M) \rightarrow H^{*,*}(E; M)$ given by $\sum_{ij} b_i \otimes i^*(c_j) \mapsto \sum_{ij} p^*(b_i) \cup c_j$ is an isomorphism.

In other words, $H^{*,*}(E; M)$ is a free $H^{*,*}(B; M)$ -module with basis $\{c_j\}$, with action $bc = p^*(b) \cup c$.

The fibers F are not only required to be the same topological space, but must be homeomorphic as $\mathbb{Z}/2$ -spaces. This is certainly the case when X is

equivariantly 1-connected and we are working in a slightly more general setting here.

The proof of this theorem will be an adaptation of the proof in [10] of the Leray-Hirsch theorem for singular cohomology.

Proof. Throughout this proof, the Mackey functor M will be understood and suppressed from the notation. Also, all tensor products are taken over $H^{*,*}(pt; M)$ and so this will be suppressed as well.

First, suppose B is a finite dimensional G -CW complex. The proof in this case will be by induction on the dimension of B . If B is 0-dimensional, then the result is clear. For the inductive step, suppose B is n -dimensional and let $B' \subset B$ be the subspace obtained by deleting a point $G/H_\alpha \times x_\alpha$ from the interior of each n -cell $G/H_\alpha \times \Delta_\alpha^n$ of B . Let $E' = p^{-1}(B')$. Then there is the following commutative diagram:

$$\begin{array}{ccccccc}
 \cdots & \rightarrow & H^{*,*}(B, B') \otimes H^{*,*}(F) & \rightarrow & H^{*,*}(B) \otimes H^{*,*}(F) & \rightarrow & H^{*,*}(B') \otimes H^{*,*}(F) \rightarrow \cdots \\
 & & \downarrow \Phi & & \downarrow \Phi & & \downarrow \Phi \\
 \cdots & \longrightarrow & H^{*,*}(E, E') & \longrightarrow & H^{*,*}(E) & \longrightarrow & H^{*,*}(E') \longrightarrow \cdots
 \end{array}$$

The top row of the diagram is exact since tensoring with a free module preserves exactness. The bottom row is also exact. Commutativity of the diagram is an easy check.

The subspace B' deformation retracts onto B^{n-1} , and so therefore the inclusion $p^{-1}(B^{n-1}) \hookrightarrow E'$ is a homotopy equivalence. Thus by induction, the right-hand Φ is an isomorphism.

Now, let $U_\alpha \subseteq \Delta_\alpha^n$ be neighborhoods of x_α so that the bundle is trivial over

each $G/H_\alpha \times U_\alpha$. Let $U = \bigcup_\alpha G/H_\alpha \times U_\alpha$ and $U' = U \cap B'$. By excision we have $H^{*,*}(B, B') \cong H^{*,*}(U, U')$. Also $H^{*,*}(E, E') \cong H^{*,*}(p^{-1}(U), p^{-1}(U')) \cong H^{*,*}(U \times F, U' \times F)$. The map $\Phi: H^{*,*}(U, U') \otimes H^{*,*}(F) \rightarrow H^{*,*}(U \times F, U' \times F)$ is an isomorphism by the Künneth formula (see [8], Theorem 8.6 and Remark 8.7), and so the left-hand Φ is an isomorphism. Now by the 5-lemma, the middle Φ is an isomorphism.

Next, suppose B is an infinite dimensional G -CW complex. Then since (B, B^n) is n -connected, $(E, p^{-1}(B^n))$ is also n -connected. There is the following commutative diagram:

$$\begin{array}{ccc} H^{*,*}(B) \otimes H^{*,*}(F) & \longrightarrow & H^{*,*}(B^n) \otimes H^{*,*}(F) \\ \downarrow \Phi & & \downarrow \Phi \\ H^{*,*}(E) & \longrightarrow & H^{*,*}(p^{-1}(B^n)) \end{array}$$

The horizontal maps are isomorphisms through dimension $(n, *)$. By the above argument, the right-hand map is an isomorphism. Thus the left-hand map is an isomorphism up to $(n, *)$. Since n was arbitrary, Φ is an isomorphism. \square

As an application, we have the following calculation. Let $F_n(\mathcal{U})$ denote the set of n -flags in $\mathcal{U} = (\mathbb{R}^{2,1})^\infty$, that is ordered n -tuples (ℓ_1, \dots, ℓ_n) of mutually orthogonal 1-dimensional subspaces of \mathcal{U} . This space inherits a $\mathbb{Z}/2$ -action from \mathcal{U} . It also has a $\text{Rep}(\mathbb{Z}/2)$ -complex structure coming from Schubert cells. All of the 0-cells in this decomposition are fixed points. There are projections $\pi_i: F_n(\mathcal{U}) \rightarrow \mathbb{RP}_{tw}^\infty$ given by taking the i th line. Let $x_i = \pi_i^*(a)$ and $y_i = \pi_i^*(b)$, where $a \in H^{1,1}(\mathbb{RP}_{tw}^\infty)$ and $b \in H^{2,1}(\mathbb{RP}_{tw}^\infty)$ are the ring generators for cohomology with constant $\mathbb{Z}/2$ coefficients.

Consider the fiber bundle $\mathbb{RP}_{tw}^\infty \longrightarrow F_n(\mathcal{U}) \xrightarrow{p} F_{n-1}(\mathcal{U})$, where p forgets

the last line. Now, the classes $x_n^e \cdot y_n^f$, where $e \in \{0, 1\}$ and $f \in \mathbb{N}$, restrict to generators of the cohomology of the fiber, so the Leray-Hirsch theorem applies, and $F_n(\mathcal{U})$ is a free $F_{n-1}(\mathcal{U})$ -module with basis these products of x_n and y_n . By induction, $H^{*,*}(F_{n-1}(\mathcal{U}))$ is polynomial on $x_1, y_1, \dots, x_{n-1}, y_{n-1}$ subject only to $x_i^2 = \rho x_i + \tau y_i$ for all i . By Leray-Hirsch, the product of x_i 's and y_j 's form an additive basis for $H^{*,*}(F_n(\mathcal{U}))$. Thus we have just proven the following.

Proposition X.2. *$H^{*,*}(F_n(\mathcal{U}))$ is polynomial on $x_1, y_1, \dots, x_n, y_n$ subject only to $x_i^2 = \rho x_i + \tau y_i$ for all i .*

CHAPTER XI

ON CHARACTERISTIC CLASSES

Characteristic classes play many interesting roles in algebraic topology. They have applications to the study of vector bundles, smooth manifolds, obstruction theory, and cobordism. In singular cohomology with \mathbb{Z} coefficients, the Chern classes generate the cohomology of the complex Grassmann manifolds. Similarly, the Stiefel-Whitney classes generate the singular cohomology with $\mathbb{Z}/2$ coefficients of the real Grassmann manifolds. The theory of $RO(G)$ -graded characteristic classes has not yet been fully developed. Some of the tools developed in this dissertation could, potentially, be used to further such a theory.

In Chapter VIII, the $RO(\mathbb{Z}/2)$ -graded cohomology of the $\mathbb{Z}/2$ -equivariant real Grassmann manifolds is shown to be free as a module over $H^{*,*}(pt; \underline{\mathbb{Z}/2})$, the cohomology of a point with $\underline{\mathbb{Z}/2}$ coefficients. However, specific generators have not yet been identified. We could simply define equivariant Stiefel-Whitney classes of the tautological bundle E_n over G_n to be these cohomology generators. Of course, we would then define equivariant Stiefel-Whitney classes of an arbitrary vector bundle $E \rightarrow X$ as pull back of these classes over a classifying map $X \rightarrow G_n$ for E . We would then want to check the usual dimension, naturality, Whitney sum, and nontriviality axioms. Already, these classes would have a different feel to them than the non-equivariant Stiefel-Whitney classes. We have seen that

$H^{*,*}(G_1; \underline{\mathbb{Z}/2}) = H^{*,*}(pt; \underline{\mathbb{Z}/2})[a, b]/(a^2 = \rho a + \tau b)$ where $|a| = (1, 1)$ and $|b| = (2, 1)$. Thus, with this definition, the tautological line bundle over G_1 would have a nonzero 1-dimensional equivariant characteristic class and a nonzero 2-dimensional class. By naturality, every line bundle would have a 2-dimensional characteristic class. This suggests that the dimension axiom is written differently for equivariant characteristic classes than it is for the singular cohomology characteristic classes.

One approach to getting generators for the cohomology of the Grassmann manifolds, and thus characteristic classes, is to use the splitting principle. Since G_n classifies equivariant vector bundles, there is a map $\mathbb{R}P^\infty \times \cdots \times \mathbb{R}P^\infty \rightarrow G_n$ classifying $E_1 \times \cdots \times E_1$, the n -fold product of the tautological line bundle over $\mathbb{R}P^\infty$. This map is invariant, up to homotopy, under the obvious action of Σ_n on $\mathbb{R}P^\infty \times \cdots \times \mathbb{R}P^\infty$. We then get a map in cohomology with $\underline{\mathbb{Z}/2}$ coefficients which, nonequivariantly, is an isomorphism. Thus, we have the following conjecture.

Conjecture XI.1. *The map $H^{*,*}(G_n(\mathcal{U})) \rightarrow (H^{*,*}(\mathbb{R}P^\infty) \otimes \cdots \otimes H^{*,*}(\mathbb{R}P^\infty))^{\Sigma_n}$ is an isomorphism.*

At this point, neither injectivity nor surjectivity of the map in cohomology is known. However, the calculations in Chapter VIII seem to support this conclusion, at least in low dimensions.

Another typical approach to nonequivariant characteristic classes uses the Leray-Serre spectral sequence. Consider the tautological bundle $E_n \rightarrow G_n$. We can then take the projective bundle $\mathbb{P}(E_n) \rightarrow G_n$ which has fibers $\mathbb{R}P^\infty$. Applying the Leray-Serre spectral sequence, we see that $E_2^{0,*} = H_{sing}^*(\mathbb{R}P^\infty)$. We can then define characteristic classes $w_i \in H_{sing}^*(G_n)$ as the image of z^{i-1} under the transgressive differential, where z is so that $H_{sing}^*(\mathbb{R}P^\infty) = \mathbb{Z}/2[z]$. Equivariantly, this procedure

can be duplicated, at least in theory. The main issue with computing is that the equivariant Serre spectral sequence of Theorem III.1 demands the use of local coefficient systems. We cannot avoid this since G_n is not equivariantly 1-connected. Local coefficients are difficult enough already in singular cohomology and are much more complicated in this equivariant setting.

Nonequivariantly, we can use the Leray-Hirsch Theorem to obtain characteristic classes. Given an n -plane bundle $E \rightarrow X$, we can create the associated projective bundle $\mathbb{P}(E) \rightarrow X$. The classifying map for E gives a map $E \rightarrow \mathbb{R}^\infty$ that is a linear injection on the fibers of E . This in turn gives a map $\mathbb{P}(E) \rightarrow \mathbb{R}\mathbb{P}^\infty$. The generators $z^i \in H_{sing}^*(\mathbb{R}\mathbb{P}^\infty; \mathbb{Z}/2)$ for $0 \leq i \leq n-1$ pull back to give a basis of the fibers $\mathbb{R}\mathbb{P}^{n-1}$ of $\mathbb{P}(E)$, which by abuse of notation will again be denoted by z^i . By the Leray-Hirsch theorem, $H_{sing}^*(\mathbb{P}(E); \mathbb{Z}/2)$ is a free $H_{sing}^*(pt; \mathbb{Z}/2)$ -module with basis the restriction of the z^i 's. This allows us to uniquely express $z^n \in H_{sing}^*(\mathbb{R}\mathbb{P}; \mathbb{Z}/2)$ as

$$1 \cdot z^n = w_1 \cdot z^{n-1} + w_2 \cdot z^{n-2} + \cdots + w_n \cdot 1$$

where $w_i \in H_{sing}^i(X; \mathbb{Z}/2)$. These are again the Steifel-Whitney classes of E . The difficulty in adapting this method to the equivariant setting is the extra hypothesis in the equivariant Leray-Hirsch theorem, which essentially imposes a requirement on the equivariant connectivity of the base space X . So again we find ourselves faced with having to handle computations with local coefficient systems.

One final technique from nonequivariant topology that we could adapt to the development of characteristic classes uses equivariant cohomology operations. These operations are developed in [4]. One could hope that when these cohomology operations are combined with a Thom isomorphism, in a method

similar to the one in [14], the result is some kind of Stiefel-Whitney classes. Such Thom isomorphisms have been developed in [5], though nothing has been done yet towards getting characteristic classes from this point of view.

REFERENCES

- [1] Shôrô Araki and Mitutaka Murayama, *τ -cohomology theories*, Japan. J. Math. (N.S.) **4** (1978), no. 2, 363–416. MR MR528864 (80d:55022a)
- [2] Glen E. Bredon, *Equivariant cohomology theories*, Bull. Amer. Math. Soc. **73** (1967), 266–268. MR MR0206946 (34 #6762)
- [3] Gunnar Carlsson and R. James Milgram, *Stable homotopy and iterated loop spaces*, Handbook of algebraic topology, North-Holland, Amsterdam, 1995, pp. 505–583. MR MR1361898 (97j:55007)
- [4] Jeffrey L. Caruso, *Operations in equivariant \mathbb{Z}/p -cohomology*, Math. Proc. Cambridge Philos. Soc. **126** (1999), no. 3, 521–541. MR MR1684248 (2000d:55028)
- [5] Steven R. Costenoble and Stefan Waner, *Equivariant ordinary homology and cohomology*, 2003.
- [6] Daniel Dugger, *An Atiyah-Hirzebruch spectral sequence for KR-theory*, K-Theory **35** (2005), no. 3-4, 213–256 (2006). MR MR2240234 (2007g:19004)
- [7] ———, *A primer on homotopy colimits*, Preprint (2008).
- [8] Daniel Dugger and Daniel C. Isaksen, *Motivic cell structures*, Algebr. Geom. Topol. **5** (2005), 615–652 (electronic). MR MR2153114 (2007c:55015)

- [9] Kevin K. Ferland and L. Gaunce Lewis, Jr., *The $RO(G)$ -graded equivariant ordinary homology of G -cell complexes with even-dimensional cells for $G = \mathbb{Z}/p$* , Mem. Amer. Math. Soc. **167** (2004), no. 794, viii+129. MR MR2025457 (2004i:55008)
- [10] Allen Hatcher, *Algebraic topology*, Cambridge University Press, 2001.
- [11] G. Lewis, J. P. May, and J. McClure, *Ordinary $RO(G)$ -graded cohomology*, Bull. Amer. Math. Soc. (N.S.) **4** (1981), no. 2, 208–212. MR MR598689 (82e:55008)
- [12] J. P. May, *Equivariant homotopy and cohomology theory*, CBMS Regional Conference Series in Mathematics, vol. 91, Published for the Conference Board of the Mathematical Sciences, Washington, DC, 1996, With contributions by M. Cole, G. Comezana, S. Costenoble, A. D. Elmendorf, J. P. C. Greenlees, L. G. Lewis, Jr., R. J. Piacenza, G. Triantafillou, and S. Waner. MR MR1413302 (97k:55016)
- [13] John McCleary, *A user's guide to spectral sequences*, second ed., Cambridge Studies in Advanced Mathematics, vol. 58, Cambridge University Press, Cambridge, 2001. MR MR1793722 (2002c:55027)
- [14] John W. Milnor and James D. Stasheff, *Characteristic classes*, Princeton University Press, Princeton, N. J., 1974, Annals of Mathematics Studies, No. 76. MR MR0440554 (55 #13428)
- [15] I. Moerdijk and J.-A. Svensson, *The equivariant Serre spectral sequence*, Proc. Amer. Math. Soc. **118** (1993), no. 1, 263–278. MR MR1123662 (93f:55023)