

A. L. Onishchik E. B. Vinberg

# Lie Groups and Algebraic Groups

Translated from the Russian  
by D. A. Leites

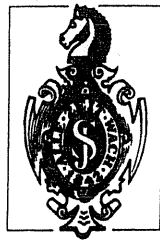

Springer-Verlag  
Berlin Heidelberg New York  
London Paris Tokyo Hong Kong

Arkadij L. Onishchik  
Department of Mathematics, Yaroslavl University  
150000 Yaroslavl, USSR



Ernest B. Vinberg  
Chair of Algebra, Moscow University  
119899 Moscow, USSR

Title of the Russian edition:  
*Seminar po gruppam Li i algebraicheskim gruppam,*  
Publisher Nauka, Moscow 1988

This volume is part of the *Springer Series in Soviet Mathematics*  
Advisers: L.D. Faddeev (Leningrad), R.V. Gamkrelidze (Moscow)

Mathematics Subject Classification (1980): 22EXX, 17BXX, 20GXX, 81-XX

ISBN 3-540-50614-4 Springer-Verlag Berlin Heidelberg New York  
ISBN 0-387-50614-4 Springer-Verlag New York Berlin Heidelberg

Library of Congress Cataloging-in-Publication Data  
Vinberg, E.B. (Ernest Borisovich)

[Seminar po gruppam Li i algebraicheskim gruppam. English]

Lie groups and algebraic groups/A.L. Onishchik, E.B. Vinberg; translated from the Russian by D.A. Leites.  
p. cm.—(Springer series in Soviet mathematics)

Translation of: Seminar po gruppam Li i algebraicheskim gruppam.

Includes bibliographical references.

ISBN 0-387-50614-4 (alk. paper)

1. Lie groups—Congresses. 2. Linear algebraic groups—Congresses.

I. Onishchik, A.L. II. Title. III. Series.

QA387.V5613 1990 512'.55—dc20 89-21693

This work is subject to copyright. All rights are reserved, whether the whole or part of the material is concerned, specifically the rights of translation, reprinting, reuse of illustrations, recitation, broadcasting, reproduction on microfilms or in other ways, and storage in data banks. Duplication of this publication or parts thereof is only permitted under the provisions of the German Copyright Law of September 9, 1965, in its current version, and a copyright fee must always be paid. Violations fall under the prosecution act of the German Copyright Law.

© Springer-Verlag Berlin Heidelberg 1990

Printed in the United States of America

Typesetting: Asco Trade Typesetting Ltd., Hong Kong  
2141/3140-543210—Printed on acid-free paper

This groups  
Univer  
way th  
groups  
semina  
[9] an  
In p  
two ne  
traditi  
e.g. ur  
(co)ho  
A di  
as a se  
We bel  
atmosf  
someti  
proofs  
in the  
essenti  
As a  
less, tw  
tangen  
with a  
vector  
textbo  
embed  
endow  
The  
theory  
acquai  
Nurr  
section  
use trip  
Chapte  
inside  
conside

## Preface

This book is based on the notes of the authors' seminar on algebraic and Lie groups held at the Department of Mechanics and Mathematics of Moscow University in 1967/68. Our guiding idea was to present in the most economic way the theory of semisimple Lie groups on the basis of the theory of algebraic groups. Our main sources were A. Borel's paper [34], C. Chevalley's seminar [14], seminar "Sophus Lie" [15] and monographs by C. Chevalley [4], N. Jacobson [9] and J-P. Serre [16, 17].

In preparing this book we have completely rearranged these notes and added two new chapters: "Lie groups" and "Real semisimple Lie groups". Several traditional topics of Lie algebra theory, however, are left entirely disregarded, e.g. universal enveloping algebras, characters of linear representations and (co)homology of Lie algebras.

A distinctive feature of this book is that almost all the material is presented as a sequence of problems, as it had been in the first draft of the seminar's notes. We believe that solving these problems may help the reader to feel the seminar's atmosphere and master the theory. Nevertheless, all the non-trivial ideas, and sometimes solutions, are contained in hints given at the end of each section. The proofs of certain theorems, which we consider more difficult, are given directly in the main text. The book also contains exercises, the majority of which are an essential complement to the main contents.

As a rule, the generally accepted terminology and notation is used. Nevertheless, two essential deviations should be mentioned. Firstly, we use the phrase tangent algebra of a Lie group for the Lie algebra associated with this group, with a view to emphasizing the construction of this Lie algebra as the tangent vector space to the Lie group. Secondly, in contrast to some monographs and textbooks, we call a Lie subgroup of a Lie group any of its subgroups which is an embedded (and necessarily closed) submanifold, while an immersed submanifold endowed with the structure of a Lie group is called a virtual Lie subgroup.

The reader is required to have linear algebra, the basics of group and ring theory and topology (including the notion of fundamental group) and to be acquainted with the main concepts of the theory of differentiable manifolds.

Numbering of subsections, formulas, theorems, etc. is performed inside each section and sections are numbered inside a chapter. In references we generally use triple numbering: for instance, Problem 2.3.17 refers to Problem 17 of § 3, Chapter 2. However, we skip the number of a chapter (or a section) in references inside of it. The last chapter is not divided into sections but in references is considered consisting of one section: § 1.

tics  
cow)

X, 81-XX

York  
lberg

D.A. Leites.

ial is concerned,  
reproduction on  
s thereof is only  
current version,  
Copyright Law.

In compiling the first draft of seminar's notes we enjoyed the help provided by E.M. Andreyev, V.G. Kac, B.N. Kimelfeld and A.C. Tolpygo. In computing the decompositions of products of irreducible representations (Table 5) B.N. Kimelfeld, B.O. Makarevich, V.L. Popov and A.G. Elashvili took part. Besides, we would like to point out that certain nice proofs were the result of seminar's workout.

We are grateful to D.A. Leites thanks to whose insistence and help this book has been written.

r  
r  
c  
v  
m  
  
e  
a  
  
b  
o  
  
e  
  
s  
C  
(J  
  
(t  
h  
  
m  
th  
fi  
ar  
m  
  
h  
p  
re  
  
ra  
el  
ar  
ar  
tic

provided  
computing  
le 5) B.N.  
t. Besides,  
f seminar's

this book

## The Translator's Preface

In my 20 years of work in mathematics, I have never met a Soviet mathematician *personally involved* in any aspect of representation theory who would not refer to the rotaprint notes of the *Seminar on algebraic groups and Lie groups* conducted by A. Onishchik and E. Vinberg with the participation of A. Elashvili, V. Kac, B. Kimelfeld, and A. Tolpygo. The notes had been published in 1969 by Moscow University in a meager number of 200 copies.

Ten years later A. Onishchik and E. Vinberg rewrote the notes and considerably enlarged them. This is a translation of the enlarged version of the notes; its abridged variant was issued in Russian in 1988.

The reader might wonder why one should have the book: why not Bourbaki's book, or S. Helgason's, or one of the excellent (text) books, say, by J. Humphreys or C. Jantzen. Here are some important reasons why:

– Nowhere are the basics of the Lie group theory so clearly and concisely expressed.

– This is the only book where the theory of semisimple Lie groups is based systematically on the technique of algebraic groups (an idea that goes back to Chevalley and is partly realized in his 3 volumes on the theory of Lie groups (1946, 1951, 1955)).

– Nowhere is the theory of real semisimple finite-dimensional Lie groups (their classification and representation theory included) expressed with such lucidity and in such detail.

– The unconventional style—the book is written as a string of problems—makes it useful as a reference to physicists (or anyone else too lazy to bother with the proof when a formulation suffices) whereas those interested in proofs will find either complete solutions or hints which should be ample help. (They were ample for some *schoolboys*, bright boys I must admit, at a specialized mathematical school in Moscow.)

– The reference chapter contains tables invaluable for anybody who actually has to compute something pertaining to representations, e.g. the table of decompositions into irreducible components of tensor products of some common representations, which is really unique.

The authors managed to display in a surprisingly small space a quite large range of topics, including correspondence between Lie groups and Lie algebras, elements of algebraic geometry and of algebraic group theory over fields of real and complex numbers, basic facts of the theory of semisimple Lie groups (real and complex; their local and global classification included) and their representations, and Levi-Malcev theorems for Lie groups and algebraic groups.

There is nothing comparable to this book by the broadness of scope in the literature on the group theory or Lie algebra theory.

At the same time, the book is self-contained indeed since only the very basics of algebra, calculus and smooth manifold theory are really needed to understand it. It is this feature that makes it compare favourably with the books mentioned above.

On the other hand, as far as algebraic groups are concerned, it cannot replace treatises like those by Humphrey or Jantzen, especially over fields of prime characteristic. Nevertheless, this book might serve better for the *first* acquaintance with these topics.

The algebraic groups, however, though vital in the approach adopted, are not the main characters of the book while the theory of Lie groups is. Still, the viewpoint of algebraic group theory enabled the authors to simplify some proofs of important theorems. Other novelties include:

- *Malcev closure* which enabled the authors to give a new proof of existence of an embedded (here: virtual) Lie subgroup with given tangent algebra;
- a proof of the fixed point theorem for compact groups of affine transformations that does not refer to integration over the group and corollaries of this theorem, such as Weyl's theorem on unitarity of a compact linear group and the algebraicity of compact linear groups;
- a generalization of V. Kac's classification of periodic automorphisms based on ideas different from those put forward by Kac originally;
- a simple proof of É. Cartan's theorem on the conjugacy of the maximal compact subgroups, that does not require any Riemannian geometry.

Lastly, I believe that some further reading on the rapidly developing generalization of the topic of the book should be recommended, including:

*(Twisted) loop algebras and, more generally, Kac-Moody algebras:*

V. Kac: *Infinite-dimensional Lie algebras*, 2nd ed. Cambridge Univ. Press, Cambridge, 1983;

V. Kac., A. Raina: *Bombay lectures on highest weight representations of infinite dimensional Lie algebras*, Adv. Series in Math. Phys. 2, World Sci., Singapore, 1987;

A. Pressley, G. Segal: *Loop groups*. Clarendon Press. Oxford, 1986.

*Lie superalgebras and stringy Lie (super) algebras:*

V. Kac: *Lie superalgebras*. Adv. Math. 26, 1977, 8-96.

M. Scheunert: *The theory of Lie superalgebras. An introduction*. LN in Math. # 716, Springer, Berlin, 1979.

D. Leites (ed): *Seminar on supermanifolds*, vols. 1 and 3. Kluwer, Dordrecht, 1990.

Finally, I wish to contribute one more problem to this compendium of problems. The importance of Table 5 has been rapidly increasing of late, in particular with the introduction of new ideas and problems in theoretical physics by V. Drinfeld ("quantum groups", quadratic algebras, etc.). The time and ingenuity-consuming task of acquiring similar data should be solved once and for all:

**Problem.** Write a program for a computer to calculate data similar to those of Table 5, e.g.  $S^n(R(A)) \otimes A^m(R(M))$ , etc., together with an *explicit* expression for the highest (lowest) weight vectors of the irreducible components of the tensor product in terms of the vectors from the initial spaces-factors<sup>1</sup>.

I am sure that the reader will enjoy the book and treasure it as does everybody I know, who was lucky enough to get a copy in Russian.

Petrozavodsk—Moscow—Stockholm, 1979–89

Dimitry Leites

---

<sup>1</sup> As far as I know, some *partial* results in this area were obtained recently in Montreal and at Moscow University.

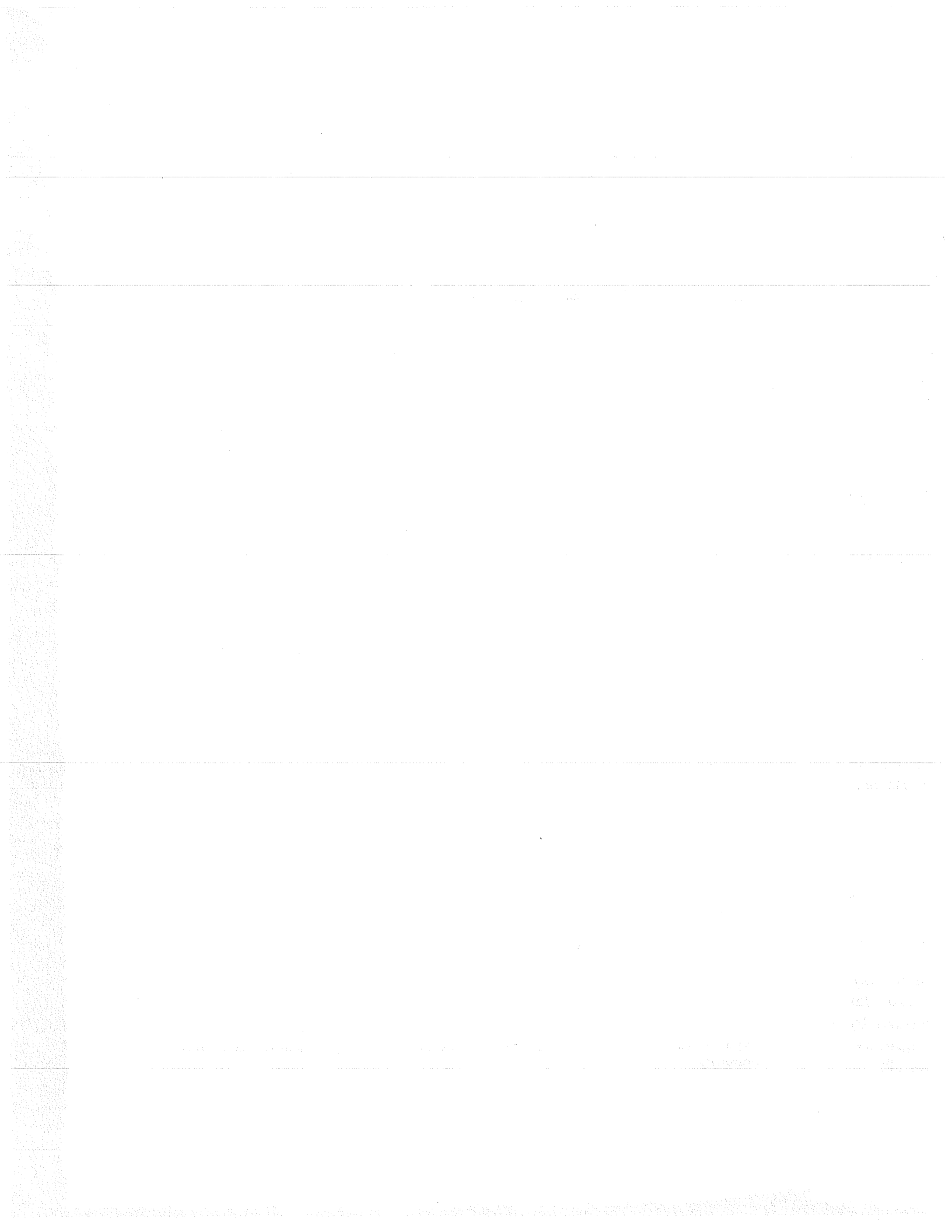

## Table of Contents

Commonly Used Symbols .....	xix
Chapter 1. Lie Groups .....	1
§ 1. Background .....	1
1° Lie Groups .....	1
2° Lie Subgroups .....	2
3° Homomorphisms, Linear Representations and Actions of Lie Groups .....	3
4° Operations on Linear Representations .....	5
5° Orbits and Stabilizers .....	6
6° The Image and the Kernel of a Homomorphism .....	8
7° Coset Manifolds and Quotient Groups .....	9
8° Theorems on Transitive Actions and Epimorphisms .....	11
9° Homogeneous Spaces .....	12
10° Inverse Image of a Lie Subgroup with Respect to a Homomorphism .....	14
11° Semidirect Product .....	15
Exercises .....	16
Hints to Problems .....	17
§ 2. Tangent Algebra .....	19
1° Definition of the Tangent Algebra .....	19
2° Tangent Homomorphism .....	21
3° The Tangent Algebra of a Stabilizer .....	22
4° The Adjoint Representation and the Jacobi Identity .....	23
5° Differential Equations for Paths on a Lie Group .....	25
6° Uniqueness Theorem for Lie Group Homomorphisms .....	27
7° Exponential Map .....	28
8° Existence Theorem for Lie Group Homomorphisms .....	30
9° Virtual Lie Subgroups .....	33
10° Automorphisms and Derivations .....	35
11° The Tangent Algebra of a Semidirect Product of Lie Groups ...	36
Exercises .....	38
Hints to Problems .....	39

§3. Connectedness and Simple Connectedness . . . . .	42
1°. Connectedness . . . . .	43
2°. Covering Homomorphisms . . . . .	44
3°. Simply Connected Covering Lie Groups . . . . .	45
4°. Exact Homotopy Sequence . . . . .	46
Exercises . . . . .	48
Hints to Problems . . . . .	48
§4. The Derived Algebra and the Radical . . . . .	50
1°. The Commutator Group and the Derived Algebra . . . . .	50
2°. Malcev Closures . . . . .	51
3°. Existence of Virtual Lie Subgroups . . . . .	52
4°. Solvable Lie Groups . . . . .	53
5°. Lie's Theorem . . . . .	54
6°. The Radical. Semisimple Lie Groups . . . . .	55
7°. Complexification . . . . .	56
Exercises . . . . .	56
Hints to Problems . . . . .	57
Chapter 2. Algebraic Varieties . . . . .	59
§1. Affine Algebraic Varieties . . . . .	59
1°. Embedded Affine Varieties . . . . .	59
2°. Morphisms . . . . .	61
3°. Zariski Topology . . . . .	62
4°. The Direct Product . . . . .	64
5°. Homomorphism Extension Theorems . . . . .	65
6°. The Image of a Dominant Morphism . . . . .	66
7°. Hilbert's Nullstellensatz . . . . .	67
8°. Rational Functions . . . . .	68
9°. Rational Maps . . . . .	69
10°. Factorization of a Morphism . . . . .	70
Exercises . . . . .	71
Hints to Problems . . . . .	72
§2. Projective and Quasiprojective Varieties . . . . .	74
1°. Graded Algebras . . . . .	74
2°. Embedded Projective Algebraic Varieties . . . . .	75
3°. Sheaves of Functions . . . . .	77
4°. Sheaves of Algebras of Rational Functions . . . . .	79
5°. Quasiprojective Varieties . . . . .	79
6°. The Direct Product . . . . .	80
7°. Flag Varieties . . . . .	83
Exercises . . . . .	84
Hints to Problems . . . . .	85

.....	42	§ 3. Dimension and Analytic Properties of Algebraic Varieties.....	87
.....	43	1°. Definition of the Dimension and its Main Properties.....	87
.....	44	2°. Derivations of the Algebra of Functions.....	88
.....	45	3°. Simple Points.....	89
.....	46	4°. The Analytic Structure of Complex and	
.....	48	Real Algebraic Varieties.....	90
.....	48	5°. Realification of Complex Algebraic Varieties.....	91
.....	50	6°. Forms of Vector Spaces and Algebras.....	92
.....	50	7°. Real Forms of Complex Algebraic Varieties.....	93
.....	50	Exercises.....	94
.....	51	Hints to Problems.....	96
.....	52	Chapter 3. Algebraic Groups.....	98
.....	53	§ 1. Background.....	98
.....	54	1°. Main Definitions.....	98
.....	55	2°. Complex and Real Algebraic Groups.....	100
.....	56	3°. Semidirect Products.....	102
.....	57	4°. Certain Theorems on Subgroups and Homomorphisms	
.....	59	of Algebraic Groups.....	102
.....	59	5°. Actions of Algebraic Groups.....	103
.....	59	6°. Existence of a Faithful Linear Representation.....	104
.....	61	7°. The Coset Variety and the Quotient Group.....	106
.....	62	Exercises.....	108
.....	62	Hints to Problems.....	108
.....	64	§ 2. Commutative and Solvable Algebraic Groups.....	110
.....	65	1°. The Jordan Decomposition of a Linear Operator.....	110
.....	66	2°. Commutative Unipotent Algebraic Linear Groups.....	111
.....	67	3°. Algebraic Tori and Quasitori.....	113
.....	68	4°. The Jordan Decomposition in an Algebraic Group.....	115
.....	69	5°. The Structure of Commutative Algebraic Groups.....	116
.....	70	6°. Borel's Theorem.....	116
.....	71	7°. The Splitting of a Solvable Algebraic Group.....	117
.....	72	8°. Semisimple Elements of a Solvable Algebraic Group.....	118
.....	74	9°. Borel Subgroups.....	118
.....	74	Exercises.....	119
.....	75	Hints of Problems.....	120
.....	77	§ 3. The Tangent Algebra.....	122
.....	79	1°. Connectedness of Irreducible Complex Algebraic Groups.....	122
.....	79	2°. The Rational Structure on the Tangent Algebra of a Torus.....	123
.....	80	3°. Algebraic Subalgebras.....	123
.....	83	4°. The Algebraic Structure on Certain Complex Lie Groups.....	124
.....	84	5°. Engel's Theorem.....	125
.....	85		

6°. Unipotent Algebraic Linear Groups .....	126	
7°. The Jordan Decomposition in the Tangent Algebra of an Algebraic Group .....	126	
8°. The Tangent Algebra of a Real Algebraic Group .....	127	
9°. The Union of Borel Subgroups and the Centralizers of Tori .....	127	
Exercises .....	128	
Hints to Problems .....	129	
§4. Compact Linear Groups .....	130	§
1°. A Fixed Point Theorem .....	130	
2°. Complete Reducibility .....	131	
3°. Separating Orbits with the Help of Invariants .....	132	
4°. Algebraicity .....	133	
Exercises .....	134	
Hints to Problems .....	134	
Chapter 4. Complex Semisimple Lie Groups .....	136	
§1. Preliminaries .....	136	
1°. Invariant Scalar Products .....	136	
2°. Algebraicity .....	138	
3°. Normal Subgroups .....	139	C
4°. Weight and Root Decompositions .....	140	
5°. Root Decompositions and Root Systems of Classical Lie Algebras .....	144	§
6°. Three-Dimensional Subalgebras .....	147	
Exercises .....	149	
Hints to Problems .....	151	
§2. Root Systems .....	153	
1°. Principal Definitions and Examples .....	153	
2°. Weyl Chambers and Simple Roots .....	156	
3°. Borel Subgroups and Maximal Tori .....	160	
4°. Weyl Group .....	162	§
5°. Dynkin Diagrams .....	164	
6°. Cartan Matrices .....	167	
7°. Classification .....	169	
8°. Root and Weight Lattices .....	172	
Exercises .....	174	
Hints to Problems .....	177	
§3. Existence and Uniqueness Theorems .....	181	
1°. Free Lie Algebras, Generators and Defining Relations .....	182	
2°. Uniqueness Theorems .....	183	

.. 126	3°. Existence Theorems .....	186
.. 126	4°. The Linearity of a Connected Complex Semisimple Lie Group ..	190
.. 127	5°. The Center and the Fundamental Group .....	191
.. 127	6°. Classification of Connected Semisimple Lie Groups .....	192
.. 128	7°. Classification of Irreducible Representations .....	193
.. 129	Exercises .....	194
.. 130	Hints to Problems .....	199
.. 130	§4. Automorphisms .....	202
.. 130	1°. The Group of Outer Automorphisms .....	202
.. 131	2°. Semisimple Automorphisms .....	203
.. 132	3°. Characters and Automorphisms of Quasi-Tori .....	205
.. 133	4°. Affine Root Decomposition .....	207
.. 134	5°. Affine Weyl Group .....	209
.. 134	6°. Affine Roots of a Simple Lie Algebra .....	211
.. 136	7°. Classification of Unitary Automorphisms of Simple Lie Algebras ..	212
.. 136	8°. Fixed Points of Semisimple Automorphisms of a Simply Connected Group .....	214
.. 136	Exercises .....	216
.. 136	Hints to Problems .....	217
.. 138		
.. 139	Chapter 5. Real Semisimple Lie Groups .....	221
.. 140	§1. Real Forms of Complex Semisimple Lie Groups and Algebras .....	221
.. 144	1°. Real Structures and Real Forms .....	221
.. 147	2°. Real Forms of Classical Lie Groups and Algebras .....	225
.. 149	3°. The Compact Real Form .....	227
.. 151	4°. Real Forms and Involutive Automorphisms .....	229
.. 153	5°. Involutive Automorphisms of Complex Simple Lie Algebras ....	232
.. 153	6°. Classification of Real Simple Lie Algebras .....	233
.. 156	Exercises .....	234
.. 160	Hints to Problems .....	236
.. 162	§2. Compact Lie Groups and Reductive Algebraic Groups .....	238
.. 164	1°. Polar Decomposition .....	238
.. 167	2°. Lie Groups with Compact Tangent Algebras .....	241
.. 169	3°. Compact Real Forms of Reductive Algebraic Groups .....	244
.. 172	4°. Linearity of Compact Lie Groups .....	245
.. 174	5°. Correspondence Between Compact Lie Groups and Reductive Algebraic Groups .....	246
.. 177	6°. Complete Reducibility of Linear Representations .....	247
.. 181	7°. Maximal Tori in Compact Lie Groups .....	249
.. 182	Exercises .....	250
.. 183	Hints to Problems .....	252

§3. Cartan Decomposition .....	254
1°. Cartan Decomposition of a Semisimple Lie Algebra .....	254
2°. Cartan Decomposition of a Semisimple Lie Group .....	256
3°. Conjugacy of Maximal Compact Subgroups .....	258
4°. Canonically Embedded Subalgebras .....	261
5°. Classification of Connected Semisimple Lie Groups .....	262
6°. Linearizer .....	264
Exercises .....	265
Hints to Problems .....	266
§4. Real Root Decomposition .....	268
1°. Maximal $\mathbb{R}$ -Diagonalizable Subalgebras .....	268
2°. Real Root Systems .....	270
3°. Satake Diagram .....	272
4°. Split Semisimple Lie Algebras .....	274
5°. Iwasawa Decomposition .....	275
Exercises .....	277
Hints to Problems .....	279
Chapter 6. Levi Decomposition .....	282
1°. Levi's Theorem .....	282
2°. Existence of a Lie Group with the Given Tangent Algebra .....	283
3°. Malcev's Theorem .....	284
4°. Algebraic Levi Decomposition .....	285
Exercises .....	287
Hints to Problems .....	288
Reference Chapter .....	289
§1. Useful Formulae .....	289
1°. Weyl Groups and Exponents .....	289
2°. Linear Representations of Complex Semisimple Lie Algebras .....	290
3°. Linear Representations of Real Semisimple Lie Algebras .....	290
§2. Tables .....	292
Table 1. Weights and Roots .....	292
Table 2. Matrices Inverse to Cartan Matrices .....	295
Table 3. Centers, Outer Automorphisms and Bilinear Invariants .....	297
Table 4. Exponents .....	299
Table 5. Decomposition of Tensor Products and Dimensions of Certain Representations .....	299
Table 6. Affine Dynkin Diagrams .....	305
Table 7. Involutive Automorphisms of Complex Simple Lie Algebras .....	307
Table 8. Matrix Realizations of Classical Real Lie Algebras .....	309

.....	254	Table 9. Real Simple Lie Algebras .....	312
.....	254	Table 10. Centers and Linearizers of Simply Connected Real	
.....	256	Simple Lie Groups.....	318
.....	258	Bibliography .....	322
.....	261	Index .....	325
.....	262		
.....	264		
.....	265		
.....	266		
.....	268		
.....	268		
.....	270		
.....	272		
.....	274		
.....	275		
.....	277		
.....	279		
.....	282		
.....	282		
.....	283		
.....	284		
.....	285		
.....	287		
.....	288		
.....	289		
.....	289		
.....	289		
s.....	290		
.....	290		
.....	292		
.....	292		
.....	295		
s.....	297		
.....	299		
.....	299		
.....	305		
.....	307		
.....	309		

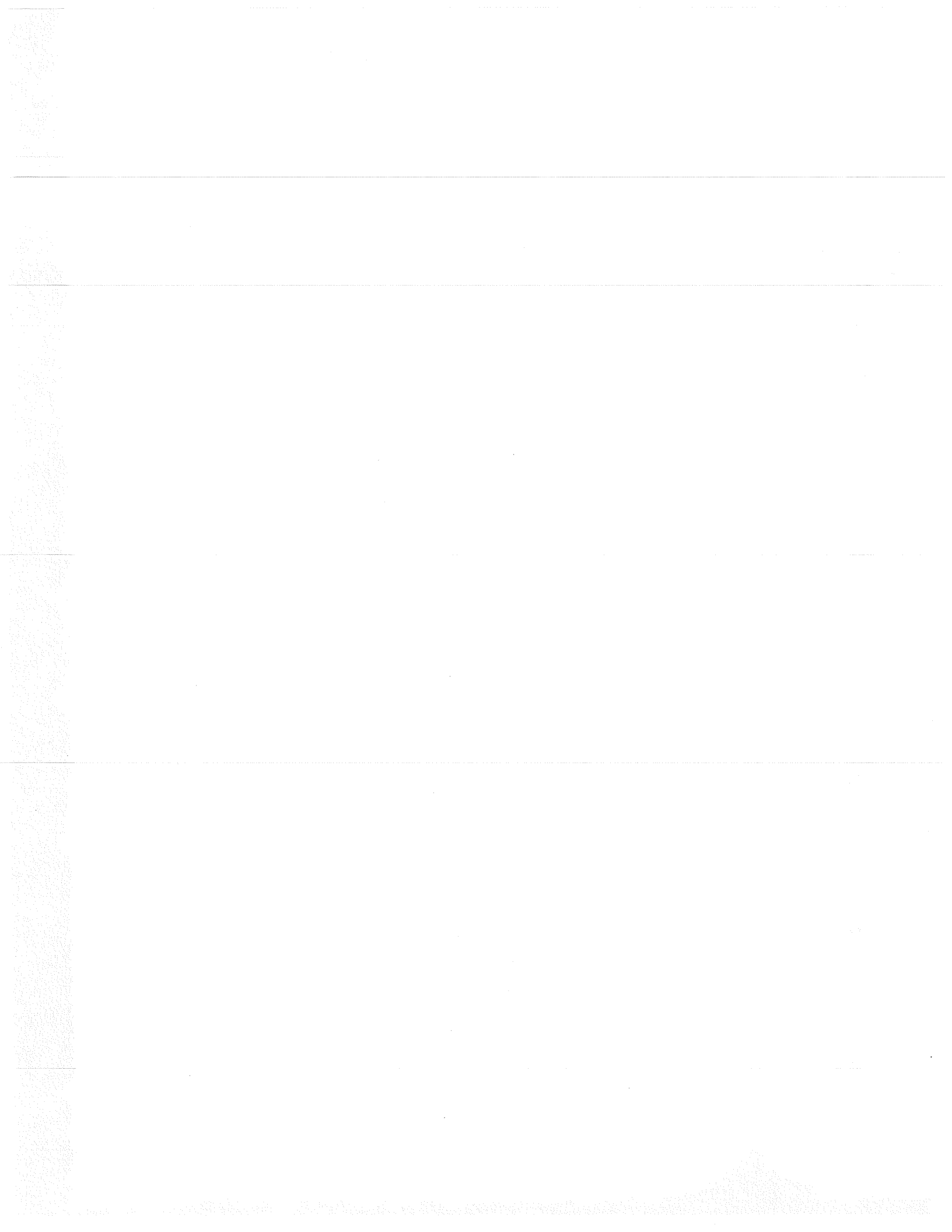

## Commonly Used Symbols

- $\mathbb{Z}$ —ring of integers
- $\mathbb{Q}, \mathbb{R}, \mathbb{C}$ —fields of rational, real and complex numbers respectively
- $\mathbb{T}$ —group of complex numbers with absolute value 1
- $\mathbb{H}$ —skew field of quaternions
- $\mathbb{A}^n$ — $n$ -dimensional coordinate affine space
- $\mathbb{P}^n$ — $n$ -dimensional coordinate projective space
- $P(V)$ —projective space associated with a vector space  $V$
- $F(V)$ —flag manifold (variety) associated with a vector space  $V$
- $V^*$ —vector space dual to a vector space  $V$
- ${}^t\varphi$ —linear map of dual spaces dual to a linear map  $\varphi$
- $A^T$ —transpose of a matrix  $A$
- $L(V)$ —(associative) algebra of linear transformations of a space  $V$
- $GL(V)$ —group of invertible linear transformations of  $V$
- $GA(V)$ —group of invertible affine transformations of  $V$
- $L_n(K)$ —(associative) algebra of  $n \times n$  matrices over a field  $K$
- $GL_n(K)$ —group of invertible  $n \times n$  matrices over a field  $K$
- det, tr—determinant and trace of a matrix or a linear transformation
- $E$ —unit matrix or identity linear transformation
- $id$ —identity map (for nonlinear maps)
- $\oplus$ —sign of the direct sum of vector spaces or algebras
- $\rtimes$ —sign of the semidirect sum of algebras (the ideal is to the left)
- $\times$ —sign of the semidirect product of groups (the normal sub group is to the left)
- $\otimes$ —sign of the tensor product of vector spaces or algebras
- $\langle S \rangle$ —linear span of a subset  $S$  of a vector space; subgroup generated by a subset  $S$  of a group
- $\subset$ —sign of inclusion, possibly identity
- $\simeq$ —sign of isomorphism.



# Chapter 1

## Lie Groups

Here the notions of the differentiable (smooth) manifold, differentiable (smooth) map, direct product of differentiable manifolds, tangent space and the differential of a map (the tangent map) are assumed to be known. Several other notions and theorems on differentiable manifolds will be recalled in the sequel.

The ground field  $K$  is either  $\mathbb{R}$  or  $\mathbb{C}$ .

Unless otherwise stated, the differentiability of functions of real variables is to be understood in such a way that in every case there are as many derivatives as needed. The differentiability of manifolds and maps is understood accordingly. The differentiability of functions of complex variables is, clearly, equivalent to their analyticity.

The Jacobi matrix of a system of differentiable functions  $f_1, \dots, f_m$  of variables  $x_1, \dots, x_n$  is denoted by  $\frac{\partial(f_1, \dots, f_m)}{\partial(x_1, \dots, x_n)}$ . For  $m = n$  its determinant (Jacobian) is denoted by  $\frac{D(f_1, \dots, f_n)}{D(x_1, \dots, x_n)}$ .

The tangent space to a manifold  $X$  at a point  $x$  is denoted by  $T_x(X)$ . The differential of a map  $f: X \rightarrow Y$  at a point  $x$  is a linear map  $T_x(X) \rightarrow T_{f(x)}(Y)$  denoted by  $d_x f$ . When it is not misleading we omit the index and write  $T(X)$  instead of  $T_x(X)$ .

We assume that every differentiable manifold has a countable base. In particular this is so in all the cases when a manifold arises as a result of some construction which starts with a manifold possessing a countable base, e.g. as a submanifold, quotient manifold, covering manifold, direct product of manifolds.

### § 1. Background

**1°. Lie Groups.** A group  $G$  endowed with a structure of a differentiable manifold over  $K$  so that the maps

$$\mu: G \times G \rightarrow G, \quad \text{where } \mu: (x, y) \mapsto xy$$

and

$$i: G \rightarrow G, \quad \text{where } i: x \mapsto x^{-1},$$

are differentiable is called a *Lie group* over  $K$ . In other words, the coordinates of the product must be differentiable functions of the coordinates of factors, and the coordinates of the inverse element must be differentiable functions of the coordinates of the element itself.

A Lie group over  $\mathbb{C}$  is also called a *complex Lie group* and a Lie group over  $\mathbb{R}$  is called a *real Lie group*. Any complex Lie group may be considered as a real Lie group of doubled dimension.

*Examples of Lie groups.* 1) The *additive group* of  $K$ . It will be denoted by  $K$ , but it is also denoted in the literature as  $G_a(K)$ .

2) The *Multiplicative group*  $K^*$  of  $K$  (also denoted in the literature as  $G_m(K)$ ).

3) The *Circle*  $\mathbb{T} = \{z \in \mathbb{C}^*: |z| = 1\}$  is a real Lie group.

4) The *general linear group*  $GL_n(K)$  of invertible  $n \times n$  matrices over  $K$ . The differentiable structure on  $GL_n(K)$  is defined as on the open subset of the vector space  $L_n(K)$  of all  $n \times n$  matrices.

5) The group  $GL(V)$  of all invertible linear transformations of an  $n$ -dimensional vector space  $V$  over  $K$  may be considered as a Lie group under the isomorphism  $GL(V) \rightarrow GL_n(K)$  which to any linear transformation assigns its matrix in a fixed basis of  $V$ . The formula describing how a matrix of a linear transformation changes under the change of basis implies that the differentiable structure on  $GL(V)$  does not depend on the choice of a basis in  $V$ .

6) The group  $GA(S)$  of (invertible) affine transformations of an  $n$ -dimensional affine space  $S$  over  $K$  is also naturally endowed with a differentiable structure which makes it a Lie group. Namely, in an affine coordinate system on  $S$  the affine transformations are expressed by formulas of the form  $X \mapsto AX + B$ , where  $X$  is the column of coordinates of a point,  $A$  an invertible square matrix and  $B$  a column vector. The entries of  $A$  and  $B$  can serve as (global) coordinates on  $GA(S)$ . The differentiable structure on  $GA(S)$  defined by them does not depend on the choice of an affine coordinate system in  $S$  since under a change of affine coordinates in  $S$  they are transformed in a differentiable way.

7) Any finite or countable group with discrete topology and the structure of a 0-dimensional differentiable manifold.

The *direct product of Lie groups* is the direct product of abstract groups endowed with the differentiable structure of the direct product of differentiable manifolds.

**Problem 1.** The direct product of Lie groups is a Lie group.

The direct product  $K^n$  of  $n$  copies of the additive group of the field  $K$  is called the  *$n$ -dimensional vector Lie group*.

**2°. Lie Subgroups.** A subgroup  $H$  of a Lie group  $G$  is called a *Lie subgroup* if it is a submanifold of the manifold  $G$ . By a *submanifold of codimension  $m$*  of a differentiable manifold  $X$  we mean a subset  $Y \subset X$  such that in an appropriate neighbourhood of any of its points it may be determined in some local coor-

ordinates by a system of equations

$$f_i(x_1, \dots, x_n) = 0 \quad \text{for } i = 1, \dots, m,$$

where  $f_1, \dots, f_m$  are differentiable functions and  $\text{rk} \frac{\partial(f_1, \dots, f_m)}{\partial(x_1, \dots, x_n)} = m$  at this point.

(Sometimes the terms “submanifold” and “Lie subgroup” respectively are understood in a wider sense. In our book to this more general interpretation would correspond the term “virtual Lie subgroup” (cf. 2.9).)

The submanifold  $Y$  is uniquely endowed with the structure of an  $(n - m)$ -dimensional differentiable manifold compatible with the induced topology so that the identity embedding  $Y \hookrightarrow X$  is a differentiable map of constant rank  $n - m$ . If, in the above notation,  $\frac{D(f_1, \dots, f_m)}{D(x_1, \dots, x_m)} \neq 0$  at a given point then the restrictions of  $x_{m+1}, \dots, x_n$  may serve as local coordinates on  $Y$  in a neighbourhood of this point.

**Problem 2.** A Lie subgroup is a Lie group.

*Examples.* 1) Any subspace of a vector space is a Lie subgroup of the vector Lie group.

2) The group  $\mathbb{T}$  (see Example 1.3) is a Lie subgroup of  $\mathbb{C}^*$  considered as a real Lie group.

3) Any discrete subgroup is a Lie subgroup.

4) The group of  $n \times n$  invertible diagonal matrices is a Lie subgroup of  $\text{GL}_n(K)$ .

5) The group of  $n \times n$  invertible (upper) triangular matrices is a Lie subgroup of  $\text{GL}_n(K)$ .

**Problem 3.** Let  $H$  be a subgroup of a Lie group  $G$ . If there is a neighbourhood  $\mathcal{O}(e)$  of the unit of  $G$  such that  $H \cap \mathcal{O}(e)$  is a submanifold, then  $H$  is a Lie subgroup.

A Lie subgroup of  $\text{GL}(V)$  (in particular, that of  $\text{GL}_n(K) = \text{GL}(K^n)$ ) is called a *linear Lie group*.

**Problem 4.** The group  $\text{SL}_n(K)$  of unimodular (i.e. of determinant 1)  $n \times n$  matrices is a Lie subgroup of codimension 1 in  $\text{GL}_n(K)$ .

**Problem 5.** The group  $\text{O}_n(K)$  of orthogonal  $n \times n$  matrices is a Lie subgroup of dimension  $n(n - 1)/2$  in  $\text{GL}_n(K)$ .

**Problem 6.** The group  $\text{U}_n$  of unitary  $n \times n$  matrices is a real Lie subgroup of dimension  $n^2$  in  $\text{GL}_n(\mathbb{C})$ .

**Problem 7.** Any Lie subgroup is closed.

**3°. Homomorphisms, Linear Representations and Actions of Lie Groups.** Let  $G$  and  $H$  be Lie groups. A map  $f: G \rightarrow H$  is called a *Lie group homomorphism* if it is both a homomorphism of abstract groups and a differentiable mapping.

A homomorphism  $f: G \rightarrow H$  is an *isomorphism* if there exists an inverse homomorphism  $f^{-1}: H \rightarrow G$ , i.e. if  $f$  is an isomorphism of abstract groups and at the same time a diffeomorphism of manifolds (however, see Corollary of Theorem 5).

*Examples.* 1) The exponential map  $x \mapsto e^x$  is a homomorphism of the additive Lie group  $K$  into the multiplicative Lie group  $K^*$ .

2) The map  $A \mapsto \det A$  is a Lie group homomorphism of  $GL_n(K)$  onto  $K^*$ .

3) For any  $g \in G$  the inner automorphism

$$a(g): x \mapsto gxg^{-1}$$

is a Lie group automorphism.

4) The map  $x \mapsto e^{ix}$  is a Lie group homomorphism of  $\mathbb{R}$  onto  $\mathbb{T}$ .

5) The map assigning to each affine transformation of an affine space  $S$  its differential (linear part) is a homomorphism of the Lie group  $GA(S)$  (cf. Example 1.6) into the Lie group  $GL(V)$ , where  $V$  is the vector space associated with  $S$ .

6) Any homomorphism of finite or countable abstract groups is a homomorphism of zero-dimensional Lie groups.

Clearly, the composition of Lie group homomorphisms is also a Lie group homomorphism.

A Lie group homomorphism of  $G$  into  $GL(V)$  is called a *linear representation* of  $G$  in the space  $V$ .

**Problem 8.** Let us assign to any matrix  $A \in GL_n(K)$  the linear transformations  $\text{Ad}(A)$  and  $\text{Sq}(A)$  in the space  $L_n(K)$  by the formulas:

$$\text{Ad}(A)(X) = AXA^{-1}, \quad \text{Sq}(A)(X) = AXA'.$$

Prove that  $\text{Ad}$  and  $\text{Sq}$  are linear representations of the Lie group  $GL_n(K)$  in the space  $L_n(K)$ .

Sometimes one considers complex linear representations of real Lie groups or real linear representations of complex Lie groups. In the first case one assumes that the group of linear transformations of a complex vector space is considered as a real Lie group, in the second one that the given complex Lie group is considered as a real one.

A group homomorphism  $\alpha$  of a Lie group  $G$  into the group  $\text{Diff } X$  of diffeomorphisms of a manifold  $X$  (which is not a Lie group in any conceivable sense) is called a *G-action* on  $X$  if the map  $G \times X \rightarrow X$ , where  $(g, x) \mapsto \alpha(g)x$ , is differentiable.

*Examples.* 1) For any Lie group  $G$  we may define the following three  $G$ -actions on  $G$  itself:

$$l(g)x = gx$$

$$r(g)x = xg^{-1}$$

$$a(g)x = gxg^{-1}$$

R

2) The natural  $GL_n(K)$ -action on the projective space  $P(K^n)$  is a Lie group action.

3) Any linear representation  $T: G \rightarrow GL(V)$  of a Lie group  $G$  may be considered as a  $G$ -action on the space  $V$ .

4) Similarly, any homomorphism  $f: G \rightarrow GA(S)$  may be considered as an action of the Lie group  $G$  on an affine space  $S$ . Such an action is called *affine*.

Clearly, the composition of a homomorphism  $f: H \rightarrow G$  and an action  $\alpha: G \rightarrow \text{Diff } X$  is the action  $\alpha \circ f: H \rightarrow \text{Diff } X$ .

When it is clear which action we are speaking about we will write  $gx$  instead of  $\alpha(g)x$ .

**4°. Operations on Linear Representations.** Suppose  $R$  and  $S$  are linear representations of a group  $G$  in spaces  $V$  and  $U$  respectively. The *sum* of  $R$  and  $S$  is the linear representation  $R + S$  of  $G$  in the space  $V \oplus U$  defined by the formula

$$(R + S)(g)(v + u) = R(g)v + S(g)u. \quad R^d(g) \dots$$

The *product* of  $R$  and  $S$  is the linear representation  $RS$  of  $G$  in the space  $V \otimes U$  defined on simple (i.e. decomposable) elements by the formula.

$$RS(g)(v \otimes u) = R(g)v \otimes S(g)u. \quad R^d(g) \dots$$

The sum and the product of any finite number of representations are defined similarly.

The *dual* (or the *contragradient*) of the representation  $R$  of a group  $G$  in a space  $V$  is the representation  $R^*$  of  $G$  in the space  $V^*$  defined by the formula,

$$R^*(g) : V^* \rightarrow V^* \quad (R^*(g)f)(v) = f(R(g)^{-1}v). \quad R^d : V^* \rightarrow V^*$$

**Problem 9.** If  $R$  and  $S$  are linear representations of a Lie group  $G$ , then  $R + S$ ,  $RS$  and  $R^*$  are also Lie group representations (i.e. they are differentiable).

For any integers  $k, l \geq 0$  the identity linear representation  $\text{Id}$  of the Lie group  $GL(V)$  in  $V$  generates the linear representation  $T_{k,l} = (\text{Id})^k (\text{Id}^*)^l$  of  $GL(V)$  in the space  $V \otimes \dots \otimes V \otimes V^* \otimes \dots \otimes V^*$  ( $k$  factors  $V$  and  $l$  factors  $V^*$ ) of tensors of type  $(k, l)$  on  $V$ . Let us give convenient formulas for  $T_{k,l}(A)$ , where  $A \in GL(V)$ , in the two cases which occur most often:  $k = 0$  and  $k = 1$ .

The tensors of type  $(0, l)$  are  $l$ -linear forms on  $V$ . For any such a form  $f$  we have

$$(T_{0,l}(A)f)(v_1, \dots, v_l) = f(A^{-1}v_1, \dots, A^{-1}v_l). \quad (1)$$

The tensors of type  $(1, l)$  are  $l$ -linear maps  $F: \underbrace{V \times \dots \times V}_{l \text{ factors}} \rightarrow V$ . For any such

a map  $F$  we have

$$(T_{1,l}(A)F)(v_1, \dots, v_l) = AF(A^{-1}v_1, \dots, A^{-1}v_l). \quad (2)$$

$$(R^d(g) f)(v) = f(R(g)^{-1} v) \quad \text{and} \quad (RS)(g) = f(R(g) \dots)$$

**Problem 10.** Prove (1) and (2).

**Problem 11.** The representations  $\text{Ad}$  and  $\text{Sq}$  considered in Problem 8 are exactly the natural linear representations of  $\text{GL}_n(K)$  in the spaces of tensors of types  $(1, 1)$  and  $(2, 0)$  respectively written in the matrix form.

If  $R$  is a linear representation of a group  $G$  in a space  $V$  and  $U \subset V$  is an invariant subspace then the *subrepresentation*  $R_U: G \rightarrow \text{GL}(U)$  and the *quotient representation*  $R_{V/U}: G \rightarrow \text{GL}(V/U)$  are defined naturally.

Evidently, any subrepresentation and any quotient representation of a linear representation of a Lie group are its linear representations (as of a Lie group).

A special role in group theory is played by one-dimensional representations which are nothing but homomorphism of a given group  $G$  into the multiplicative subgroup of the ground field. They are called *characters*<sup>1</sup> of the group  $G$ . Characters form a group with respect to the multiplication of representations; the inversion in this group is the passage to the dual representation.

In the context of the Lie group theory characters are supposed to be differentiable. In this book we will only consider complex characters of (real and complex) Lie groups. The group of complex characters of a Lie group  $G$  will be denoted by  $\mathcal{X}(G)$ .

The additive notation is traditionally used in the group of characters:

$$(\chi_1 + \chi_2)(g) = \chi_1(g)\chi_2(g), \quad (\chi_1, \chi_2 \in \mathcal{X}(G), g \in G).$$

**5°. Orbits and Stabilizers.** Suppose  $\alpha$  is an action of a Lie group  $G$  on a manifold  $X$  and let  $x \in X$  be a point. Consider the map

$$\alpha_x: G \rightarrow X, \quad \text{where } \alpha_x: g \mapsto \alpha(g)x.$$

Its image is the orbit  $\alpha(G)x$  of the point  $x$  and the inverse image of  $x$  is nothing but its stabilizer

$$G_x = \{g \in G: \alpha(g)x = x\}.$$

The inverse images of the other points of the orbit are left cosets of  $G$  with respect to  $G_x$ .

**Problem 12.** Prove that  $\alpha_x$  is differentiable and its rank is constant.

Recall that a differentiable map  $f: X \rightarrow Y$  of constant rank is linearizable in a neighbourhood of any point of  $X$ . This implies that

(1) the inverse image of any point  $y = f(x)$  is a submanifold of codimension  $k = \text{rk } f$  in  $X$  and  $T_x(f^{-1}(y)) = \text{Ker } d_x f$ ;

<sup>1</sup>In the representation theory the term "character" is more often understood in a wider sense as a trace of any (not necessarily one-dimensional) linear representation. However, we will not consider characters in this wider sense and the term "character" will always be understood as above.

(2) for any point  $x \in X$  the image of any sufficiently small neighbourhood  $\mathcal{O}(x)$  is a  $k$ -dimensional submanifold in  $Y$ , and  $T_{f(x)}(f(\mathcal{O}(x))) = \text{Im } d_x f$ .

Besides,

(3) if  $f(X)$  is a submanifold in  $Y$  then  $\dim f(X) = k$ .

Indeed, if we had had  $\dim f(X) > k$ , then by (2) the manifold  $f(X)$  would have been covered by a countable set of submanifolds of a smaller dimension, but this is impossible.

The listed properties of constant rank maps and Problem 12 immediately imply

**Theorem 1.** *Suppose  $\alpha$  is an action of a Lie group  $G$  on a differentiable manifold  $X$ . For any  $x \in X$  the map  $\alpha_x$  is of constant rank. Let  $\text{rk } \alpha_x = k$ , then*

1) *the stabilizer  $G_x$  is a Lie subgroup of codimension  $k$  in  $G$  and  $T_e(G_x) = \text{Ker } d_e \alpha_x$ ;*

2) *for any sufficiently small neighbourhood  $\mathcal{O}(e)$  of the unit of  $G$  the subset  $\alpha(\mathcal{O}(e))x$  is a submanifold of dimension  $k$  in  $X$  and  $T_x(\alpha(\mathcal{O}(e))x) = \text{Im } d_e \alpha_x$ ;*

3) *if the orbit  $\alpha(G)x$  is a submanifold in  $X$ , then  $\dim \alpha(G)x = k$ .*

Note that an orbit is not always a submanifold. (A counterexample will be given in the following subsection.)

Therefore the following statement is of interest to us:

**Problem 13.** Any orbit of a compact Lie group action is a closed submanifold.

The most important examples of compact Lie groups (besides finite ones) are the  $n$ -dimensional torus  $\mathbb{T}^n$  (the direct product of  $n$  copies of  $\mathbb{T}$ ), the orthogonal group  $O_n (= O_n(\mathbb{R}))$  and the unitary group  $U_n$ . To prove the compactness of  $O_n$  note that it is distinguished in the space  $L_n(\mathbb{R})$  of all real matrices by algebraic equations  $\sum_k a_{ik} a_{jk} = \delta_{ij}$ , hence is closed in  $L_n(\mathbb{R})$ . These equations imply  $|a_{ij}| \leq 1$  which means that  $O_n$  is bounded in  $L_n(\mathbb{R})$ . The compactness of  $U_n$  is proved similarly. We will continue the discussion of properties of compact Lie groups and their orbits in §3.4.

Statement 1) of the theorem may be used to prove the fact that a given subgroup  $H$  of a Lie group  $G$  is a Lie subgroup. For this it suffices to realize  $H$  as the stabilizer of a point for some action of the Lie group  $G$ . Most (if not all) interesting Lie subgroups arise in this way. If the orbit of a given point under this action is a submanifold of a known dimension, then the dimension of  $H$  may be computed using statement 3).

We can apply this to the representation of the Lie group  $GL(V)$  in the space of tensors (see 4°) to find that the group of invertible linear transformations preserving a tensor is a linear Lie group.

*Examples.* 1) Consider the representation of  $GL(V)$  in the space  $B_+(V)$  of symmetric bilinear forms (i.e. symmetric tensors of type  $(0, 2)$ ). The group  $O(V, f)$  of invertible linear transformations preserving a symmetric bilinear form  $f$  is a linear Lie group. If  $f$  is nondegenerate, then its orbit is open in  $B_+(V)$ , hence

$$\dim O(V, f) = \dim GL(V) - \dim B_+(V) = n^2 - \frac{n(n+1)}{2} = \frac{n(n-1)}{2},$$

where  $n = \dim V$ .

2) Similarly, consider the representation of  $GL(V)$  in the space  $B_-(V)$  of skew-symmetric bilinear forms. The group  $Sp(V, f)$  of invertible linear transformations preserving a skew-symmetric bilinear form  $f$  is a linear Lie group. If  $f$  is nondegenerate, then

$$\dim Sp(V, f) = \dim GL(V) - \dim B_-(V) = n(n+1)/2$$

3) Consider the representation of  $GL(V)$  in the space of algebras on  $V$  (i.e. tensors of the type  $(1, 2)$ ). We find that the group of automorphisms of any algebra is a linear Lie group.

**6°. The Image and the Kernel of a Homomorphism.** Suppose  $f: G \rightarrow H$  is a Lie group homomorphism. Consider the action  $\alpha$  of  $G$  on the manifold  $H$  defined by the formula

$$\alpha(g)h = f(g)h,$$

where the right-hand side is the product of elements of  $H$ . In other words,  $\alpha$  is the composition of  $f$  and the action  $l$  or  $H$  on itself by left translations.

Let  $e$  be the unit of  $H$ . Then  $\alpha_e = f$  and  $\alpha(G)e = f(G)$ ; the stabilizer of  $e$  with respect to  $\alpha$  coincides with  $\text{Ker } f$ . Theorem 1 being applied to the action  $\alpha$  and the point  $e \in H$  yields the following theorem.

**Theorem 2.** Suppose  $f: G \rightarrow H$  is a Lie group homomorphism. Then  $f$  is a mapping of constant rank. Let  $\text{rk } f = k$ . Then

- 1)  $\text{Ker } f$  is a Lie subgroup of codimension  $k$  in  $G$  and  $T_e(\text{Ker } f) = \text{Ker } d_e f$ ;
- 2) for any sufficiently small neighbourhood  $\mathcal{O}(e)$  of the unit of  $G$  the subset  $f(\mathcal{O}(e))$  is a submanifold of dimension  $k$  in  $H$  and  $T_e(f(\mathcal{O}(e))) = \text{Im } d_e f$ ;
- 3) if  $f(G)$  is a Lie subgroup in  $H$ , then  $\dim f(G) = k$ .

*Example.* Consider the homomorphism  $\det: GL_n(K) \rightarrow K^*$ . Its kernel is the group  $SL_n(K)$  of unimodular matrices. Since  $\det(GL_n(K)) = K^*$ , we have  $\text{rk } \det = 1$ . Hence  $SL_n(K)$  is a Lie subgroup of codimension 1 in  $GL_n(K)$ .

Clearly, if  $f(G)$  is a submanifold then  $f(G)$  is a Lie subgroup in  $H$ . The following example shows that  $f(G)$  is not always a submanifold.

**Problem 14.** Let  $f: \mathbb{R} \rightarrow \mathbb{T}^n$  be a Lie group homomorphism defined by the formula

$$f(x) = (e^{ia_1x}, \dots, e^{ia_nx}), \quad \text{where } a_1, \dots, a_n \in \mathbb{R}.$$

Its image  $f(\mathbb{R})$  is a Lie subgroup in  $\mathbb{T}^n$  if and only if  $a_1, \dots, a_n$  are commensurable (i.e. their ratios are rational).

For  $n = 2$  and incommensurable  $a_1, a_2$  the subgroup  $f(\mathbb{R})$  is a dense winding of a (two-dimensional) torus.

It can be shown that, for any  $n$ , if  $a_1, \dots, a_n$  are not related by any nontrivial linear relation with rational coefficients the subgroup  $f(\mathbb{R})$  is dense in  $\mathbb{T}^n$ .

Problem 13 implies that the image of a compact Lie group under a homomorphism is always a Lie subgroup.

**7°. Coset Manifolds and Quotient Groups.** On the coset space of a Lie group with respect to a Lie subgroup, a differentiable structure can be naturally defined. To formulate the corresponding theorem we need several definitions.

Let  $X$  and  $Y$  be differentiable manifolds and  $p: X \rightarrow Y$  a differentiable surjective map. For any function  $f$  defined on a subset  $U \subset Y$  we determine the function  $p^*f$  on  $p^{-1}(U)$  by the formula

$$(p^*f)(x) = f(p(x)).$$

The map  $p$  is called a *quotient map* if

- 1) a subset  $U \subset Y$  is open if and only if  $p^{-1}(U)$  is open in  $X$ ;
- 2) a function  $f$ , defined on an open subset  $U \subset Y$ , is differentiable if and only if so is  $p^*f$ .

A map  $p$  is called a *trivial bundle with the fibre  $Z$*  (where  $Z$  is also a differentiable manifold), if there is a diffeomorphism

$$v: Y \times Z \rightarrow X$$

satisfying

$$p(v(y, z)) = y.$$

A map  $p$  is called a *locally trivial bundle with the fibre  $Z$*  if  $Y$  can be covered by open subsets such that  $p$  is a trivial bundle with the fibre isomorphic to  $Z$  over each of these subsets.

**Problem 15.** Any locally trivial bundle is a quotient map.

**Problem 16.** If a quotient map  $p$  enters the commutative triangle

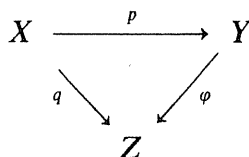

where  $Z$  is a differentiable manifold and  $q$  is a differentiable map, then  $\varphi$  is differentiable. If in the above triangle the map  $q$  also is a quotient map and  $\varphi$  is bijective, then  $\varphi$  is a diffeomorphism.

The second assertion of Problem 16 may be interpreted as follows: given a map  $p$  of a differentiable manifold  $X$  onto a set  $Y$  there exists on  $Y$  no more than one differentiable structure such that  $p$  is a factorization with respect to this structure.

**Theorem 3.** *Let  $G$  be a Lie group and  $H$  its Lie subgroup. There is a unique differentiable structure on the space  $G/H$  of left cosets such that the canonical map*

$$p: G \rightarrow G/H, \quad \text{where } p: g \mapsto gH,$$

*is a quotient map. With respect to this structure*

- 1)  $p$  is a locally trivial bundle;
- 2) the natural  $G$ -action on  $G/H$  (by left translations) is differentiable;
- 3) if  $H$  is a normal subgroup then the quotient group  $G/H$  is a Lie group.

*Proof.* In  $G/H$ , introduce a topology assuming a subset  $U \subset G/H$  open if and only if  $p^{-1}(U)$  is open in  $G$ .

**Problem 17.**  $p$  is continuous and open.

**Problem 18.**  $G/H$  is a Hausdorff space.

The key point in the proof of Theorem 3 is the following

**Problem 19.** There is a submanifold  $S \subset G$  containing the unit  $e$  and such that the map

$$v: S \times H \rightarrow G, \quad \text{where } v: (s, h) \mapsto sh,$$

is a diffeomorphism of the direct product  $S \times H$  onto an open subset of  $G$ .

Under  $p$  the submanifold  $S$  is bijectively mapped onto a neighbourhood  $U$  of the point  $p(e) = H$  in the space  $G/H$ . Let us transport the differentiable structure from  $S$  to  $U$  by means of  $p$ . Then  $p$  is a trivial bundle on  $U$ .

Further, for any  $g \in G$  transport the differentiable structure from  $U$  to  $gU$  by means of the left translation by  $g$ . Since  $p$  commutes with the left translations, and by the definition of the differentiable structure on  $gU$  the map  $p$  defines a trivial bundle structure on  $gU$ . In particular, it is a quotient map over  $gU$  (Problem 15). This implies that for any  $g_1, g_2 \in G$  the differentiable structures defined on  $g_1U$  and  $g_2U$  coincide on  $g_1U \cap g_2U$  (Problem 16). Thus, our definition of the differentiable structure on  $G/H$  implies that  $p$  is a locally trivial bundle with respect to this structure.

To prove statements 2) and 3) of the theorem we need

**Problem 20.** Let  $p_i: X_i \rightarrow Y_i$  be a locally trivial bundle with the fibre  $Z_i$  for  $i = 1, 2$ . Then

$$p_1 \times p_2: X_1 \times X_2 \rightarrow Y_1 \times Y_2, \quad \text{where } p_1 \times p_2: (x_1, x_2) \mapsto (p_1(x_1), p_2(x_2)),$$

is a locally trivial bundle with the fibre  $Z_1 \times Z_2$ .

The r

which e

where  $\mu$   
hence a  
of  $id \times j$   
Simila

we dedu  
when  $H$   
In coi

is onto a  
theorem

**Probl**  
be a nor  
action o

Runn  
G. This  
stabilize

**Probl**  
containe

8°. TI  
G on a  
that  $\alpha(g$   
triangle

The natural  $G$ -action on  $G/H$  is defined by the map

$$\lambda: G \times G/H \rightarrow G/H, \text{ where } \lambda: (g', gH) \mapsto g'gH,$$

which enters the commutative diagram

$$\begin{array}{ccc} G \times G & \xrightarrow{\mu} & G \\ \text{id} \times p \downarrow & \searrow q & \downarrow p \\ G \times G/H & \xrightarrow{\lambda} & G/H \end{array}$$

where  $\mu$  is the multiplication in  $G$ . The map  $\text{id} \times p$  is a locally trivial bundle, hence a quotient map. Applying Problem 16 to the commutative triangle made of  $\text{id} \times p$ ,  $q = p \circ \mu$  and  $\lambda$  we see that  $\lambda$  is a differentiable mapping.

Similarly, from the commutative diagram

$$\begin{array}{ccc} G \times G & \xrightarrow{\mu} & G \\ p \times p \downarrow & \searrow & \downarrow p \\ G/H \times G/H & \xrightarrow{\mu_H} & G/H \end{array}$$

we deduce the differentiability of the multiplication  $\mu_H$  in the quotient group  $G/H$  when  $H$  is a normal subgroup.

In conclusion, note that the tangent map

$$d_e p: T_e(G) \rightarrow T_{p(e)}(G/H)$$

is onto and its kernel is  $T_e(H)$ . (This follows for instance, from heading 1) of the theorem). Therefore  $T_{p(e)}(G/H)$  is naturally identified with  $T_e(G)/T_e(H)$ .

**Problem 21.** Let a Lie group  $G$  act on a differentiable manifold  $X$  and let  $N \subset G$  be a normal Lie subgroup contained in the kernel of this action. Then the induced action of the Lie group  $G/N$  on  $X$  is differentiable.

Running ahead, note that the kernel itself is a (normal) Lie subgroup of  $G$ . This follows from Theorem 4.2 since the kernel is the intersection of all stabilizers.

**Problem 22.** Let  $H$  be a Lie subgroup of  $G$  and  $N$  a normal Lie subgroup contained in  $H$ . Then  $H/N$  is a Lie subgroup of  $G/N$ .

**8°. Theorems on Transitive Actions and Epimorphisms.** An action  $\alpha$  of a group  $G$  on a set  $X$  is called *transitive* if for any  $x, x' \in X$  there is a  $g \in G$  such that  $\alpha(g)x = x'$ . In this case the map  $\alpha_x$  is onto and we have the commutative triangle

$$\begin{array}{ccc}
 G & & X \\
 \downarrow p & \searrow \alpha_x & \\
 G/G_x & \xrightarrow{\beta_x} & X
 \end{array}
 \tag{3}$$

where  $\beta_x$  is a bijection commuting with the  $G$ -action.

**Theorem 4.** Let  $G$  be a Lie group and  $\alpha$  its transitive action on a differentiable manifold  $X$ . For any  $x \in X$  the map

$$\beta_x: G/G_x \rightarrow X, \quad \text{where } \beta_x: gG_x \mapsto \alpha(g)x,$$

is a diffeomorphism commuting with the  $G$ -action.

*Proof.* Since  $p$  is a quotient map, the commutativity of (3) implies that  $\beta_x$  is a differentiable map (Problem 16). By Theorem 1

$$\text{rk } \alpha_x = \dim X = \dim G/G_x$$

so the tangent map  $d\alpha_x$  is onto (at each point). Hence, the map  $d\beta_x$  is an isomorphism of tangent spaces. Therefore  $\beta_x$  is a diffeomorphism.

Now, let  $f: G \rightarrow H$  be an epimorphism of Lie groups. Then the  $G$ -action  $\alpha$  on  $H$  defined in 6° is transitive. Applying Theorem 4 to this action we obtain the following theorem.

**Theorem 5.** Let  $f: G \rightarrow H$  be a Lie group epimorphism. The map

$$f: G/\text{Ker } f \rightarrow H, \quad g \text{Ker } f \mapsto f(g)$$

is a Lie group isomorphism.

**Corollary.** A bijective Lie group homomorphism is an isomorphism.

**9°. Homogeneous Spaces.** A differentiable manifold  $X$  with a transitive action of a Lie group  $G$  on it is called a *homogeneous space of  $G$* . By Theorem 4 any homogeneous space of  $G$  is isomorphic to  $G/H$ , where  $H \subset G$  is a Lie subgroup, with the canonical  $G$ -action. Homogeneous spaces are the most important and interesting objects of geometry.

In geometry significant is not the  $G$  itself but its image in  $\text{Diff } X$ . Therefore in the study of homogeneous spaces from this point of view we may confine ourselves to effective actions (see Problem 21).

The linear group  $d_x G_x (x \in X)$  is called the *isotropy group* of the homogeneous space  $X$  (at  $x$ ).

*Examples.* 1) The spaces of constant curvature—the Euclidean space  $E^n$ , the sphere  $S^n$  ( $n \geq 2$ ) and the Lobachevsky space  $L^n$  ( $n \geq 2$ )—may be considered as

homogeneous spaces of their groups of motions which are in a natural sense (real) Lie groups and act in a differentiable way.

(3) The group of motions of the Euclidean space is a Lie subgroup of the group of affine transformations (cf. Example in 10°). Its construction is described in Example 11.2. The sphere  $S^n$  is naturally embedded in  $\mathbb{R}^{n+1}$  so that its motions are induced by orthogonal transformations of  $\mathbb{R}^{n+1}$ . This establishes an isomorphism of the group of motions of  $S^n$  with the Lie group  $O_{n+1}$ . Similarly,  $L^n$  is embedded in  $\mathbb{R}^{n+1}$  as a connected component of the two-sheeted hyperboloid  $x_0^2 - x_1^2 - \dots - x_n^2 = 1$ , so that its motions are induced by the pseudoorthogonal (preserving the quadratic form  $x_0^2 - x_1^2 - \dots - x_n^2$ ) transformations of  $\mathbb{R}^{n+1}$  mapping each connected component of this hyperboloid onto itself. This establishes an isomorphism of the group of motions of  $L^n$  with the subgroup of index 2 of the Lie group  $O_{1,n}$  of all pseudoorthogonal transformations (cf. Problem 3.10).

In these three cases the stabilizer of a point is isomorphic to  $O_n$ . More precisely it is isomorphic (via the differential) to the isotropy group which coincides with the full orthogonal group of the tangent space.

The spaces of constant curvature may be characterized as simply connected homogeneous spaces of real Lie groups satisfying one of the following equivalent conditions (see e.g. [47]):

- a) there exists an invariant Riemannian metric of constant sectional curvature;
- b) the isotropy group coincides with the full orthogonal group of the tangent space (with respect to some Euclidean metric).

2) The *Grassmann variety*  $Gr_{n,p}(K)$  of all  $p$ -dimensional subspaces of  $K^n$  is a homogeneous space of  $GL_n(K)$ . The stabilizer of the subspace determined by  $x_{p+1} = \dots = x_n = 0$  consists of matrices of the form

$$\begin{pmatrix} A & C \\ O & B \end{pmatrix}, \text{ where } A \in GL_p(K), B \in GL_{n-p}(K),$$

and its codimension in  $GL_n(K)$  is  $p(n-p)$ . Therefore  $\dim Gr_{n,p}(K) = p(n-p)$ .

3) The manifold of positive definite symmetric real  $n \times n$  matrices is a homogeneous space of  $GL_n(\mathbb{R})$  with respect to the action Sq defined in Problem 8 (cf. Example 5.1). Since the stabilizer of the unit matrix under this action coincides with the orthogonal group  $O_n$ , this homogeneous space is isomorphic to  $GL_n(\mathbb{R})/O_n$ .

4) The group manifold of a Lie group  $G$  may be considered as a homogeneous space of the Lie group  $G \times G$  with respect to the action  $\beta$  defined by the formula

$$\beta(g_1, g_2)x = g_1 x g_2^{-1} \quad (g_1, g_2, x \in G)$$

The stabilizer of  $e \in G$  is the diagonal of  $G \times G$  (isomorphic to  $G$ ) and the isotropy group coincides with the adjoint group  $Ad G$  (see 2.4).

**10°. Inverse Image of a Lie Subgroup with Respect to a Homomorphism**

**Theorem 6.** Suppose  $f: G \rightarrow H$  is a Lie group homomorphism and  $H_1$  is a Lie subgroup in  $H$ . Then  $G_1 = f^{-1}(H_1)$  is a Lie subgroup in  $G$  and

$$T_e(G_1) = (d_e f)^{-1}(T_e(H_1)).$$

*Proof.* Consider the composition  $\alpha = \beta \circ f$  of the natural  $H$ -action  $\beta$  on  $H/H_1$  and the homomorphism  $f$ :

$$\alpha = \beta \circ f: G \rightarrow \text{Diff } H/H_1.$$

The subgroup  $G_1 = f^{-1}(H_1)$  is the stabilizer of the point  $p(e) \in H/H_1$ , where  $p$  is the canonical projection of  $H$  onto  $H/H_1$ . By Theorem 1  $G_1$  is a Lie subgroup and

$$T_e(G_1) = \text{Ker } d_e \alpha_{p(e)}.$$

Clearly,  $\alpha_{p(e)} = p \circ f$ . Hence,

$$d_e \alpha_{p(e)} = d_e p \circ d_e f.$$

Since  $\text{Ker } d_e p = T_e(H_1)$ , we have

$$\text{Ker } d_e \alpha_{p(e)} = (d_e f)^{-1}(T_e(H_1)).$$

The theorem is proved.  $\square$

*Example.* Let  $S$  be a Euclidean affine space,  $V$  the associated Euclidean vector space and  $d: \text{GA}(S) \rightarrow \text{GL}(V)$  the homomorphism assigning to each affine transformation its differential, cf. Example 3.5. Then  $d^{-1}(\text{O}(V))$  is the group of motions of  $S$ . Theorem 6 enables us to deduce that the group of motions of a Euclidean space is a Lie subgroup in the Lie group of all affine transformations.

Let us show several applications of Theorem 6 which will be used in what follows.

**Problem 23.** Let  $H_1$  and  $H_2$  be Lie subgroups of  $G$ . Then  $H_1 \cap H_2$  is also a Lie subgroup and  $T_e(H_1 \cap H_2) = T_e(H_1) \cap T_e(H_2)$ .

Observe that the intersection of submanifolds is not, in general, a submanifold. For example, in  $\mathbb{C}^3$ , the intersection of the nonsingular surface  $z = x^2 + y^3$  with the plane  $z = 0$  is a singular curve (cuspidal cubic curve) which is not a submanifold.

The statement of Problem 21 can be easily extended to any finite number of subgroups. It is also valid for an infinite number of subgroups (see Theorem 4.2).

In the f  
Since GL  
any point

**Problem**  
and  $U \subset$

is a Lie su

**Problem**  
Then

is a Lie su

**11°. Ser**  
ture of Lie  
Recall t  
product of

where  $b$  is  
the group  
precisely,  
subgroup  
identified

The subgr  
semidirect  
One say

$G_2$  if  
1)  $G_1$  is  
2)  $G_1 G_2$   
3)  $G_1 \cap$   
In this c

In the following two problems Theorem 6 is applied to a linear representation. Since  $GL(V)$  is an open subset in the space  $L(V)$  the tangent space to  $GL(V)$  (at any point) is naturally identified with  $L(V)$ .

**Problem 24.** Let  $R: G \rightarrow GL(V)$  be a linear representation of a Lie group  $G$  and  $U \subset V$  a subspace. Then

$$G(U) = \{g \in G: R(g)U \subset U\}$$

is a Lie subgroup in  $G$  and

$$T_e(G(U)) = \{\xi \in T_e(G): (d_e R)(\xi)U \subset U\}.$$

**Problem 25.** Under the conditions of Problem 22 let  $W$  be a subspace of  $U$ . Then

$$G(U, W) = \{g \in G: (R(g) - E)U \subset W\}$$

is a Lie subgroup in  $G$  and

$$T_e(G(U, W)) = \{\xi \in T_e(G): (d_e R)(\xi)U \subset W\}.$$

**11°. Semidirect Product.** In many cases it is convenient to describe the structure of Lie groups in terms of semidirect products.

Recall that the *semidirect product* of abstract groups  $G_1$  and  $G_2$  is the direct product of sets  $G_1$  and  $G_2$  endowed with the group structure via

$$(g_1, g_2)(h_1, h_2) = (g_1 \cdot b(g_2)h_1, g_2 h_2), \tag{4}$$

where  $b$  is a homomorphism of  $G_2$  into the group  $\text{Aut } G_1$  of automorphisms of the group  $G_1$ . We will denote the semidirect product by  $G_1 \rtimes G_2$  or more precisely, by  $G_1 \rtimes_b G_2$ . The elements of the form  $(g_1, e)$  (resp.  $(e, g_2)$ ) form a subgroup in  $G_1 \rtimes_b G_2$  isomorphic to  $G_1$  (resp.  $G_2$ ). This subgroup is usually identified with  $G_1$  (resp.  $G_2$ ). The subgroup  $G_1$  is normal and

$$g_2 g_1 g_2^{-1} = b(g_2)g_1 \quad (g_1 \in G_1, g_2 \in G_2). \tag{5}$$

The subgroup  $G_2$  is normal if and only if  $b$  is trivial i.e.  $b(G_2) = e$ ; in this case the semidirect product coincides with the direct product  $G_1 \times G_2$ .

One says that a group  $G$  splits into a semidirect product of subgroups  $G_1$  and  $G_2$  if

- 1)  $G_1$  is normal;
- 2)  $G_1 G_2 = G$ ;
- 3)  $G_1 \cap G_2 = \{e\}$ .

In this case we have the isomorphism

$$G_1 \times G_2 \cong G, \quad (g_1, g_2) \mapsto g_1 g_2, \tag{6}$$

where  $b: G_2 \rightarrow \text{Aut } G_1$  is the homomorphism defined by (5) and we will write  $G = G_1 \rtimes G_2$  or  $G = G_2 \ltimes G_1$ .

A *semidirect product of Lie groups*  $G_1$  and  $G_2$  is defined as a semidirect product of abstract groups endowed with a differentiable structure as the direct product of differentiable manifolds. It is additionally required that  $b$  define differentiable  $G_2$ -action on  $G_1$ , i.e. that the map

$$G_1 \times G_2 \rightarrow G_1, \quad (g_1, g_2) \mapsto b(g_2)g_1 \quad (7)$$

be differentiable. (In particular, the automorphism  $b(g_2)$  of  $G_1$  must be differentiable for any  $g_2 \in G_2$ ). This ensures the differentiability of group actions in the semidirect product.

One says that a *Lie group*  $G$  splits into a semidirect product of Lie subgroups  $G_1$  and  $G_2$  if it splits into their semidirect product as an abstract group. In this case the action  $b$  of  $G_2$  on  $G_1$  defined by (5) is differentiable and the abstract isomorphism (6) due to the corollary of Theorem 5 is a Lie group isomorphism.

*Examples.* 1) Let  $R: G \rightarrow \text{GL}(V)$  be a linear representation of a Lie group  $G$ . Then we may form a semidirect product  $V \rtimes_R G$  where  $V$  is considered as a vector Lie group.

2) Let  $\text{Id}$  be the identity linear representation of  $\text{GL}(V)$  in  $V$ . Then there is an isomorphism

$$V \rtimes_{\text{Id}} \text{GL}(V) \cong \text{GA}(V)$$

assigning to each  $v \in V$  a parallel translation

$$t_v: x \mapsto x + v, \quad (x \in V).$$

3) Every Lie subgroup  $G \subset \text{GA}(V)$  containing all parallel translations splits into the semidirect product of the group of parallel translations and some linear Lie group

$$H = dG \subset \text{GL}(V).$$

In particular, the group of motions of the Euclidean space  $E^n$  splits into the semidirect product of the group of parallel translations and the orthogonal group  $O_n$ .

4) The Lie group of invertible triangular matrices splits into the semidirect product of the normal Lie subgroup of unitriangular matrices (triangular with the units on the diagonal) and the Lie subgroup of invertible diagonal matrices.

### Exercises

1) If a group is endowed with the structure of a differentiable manifold such that the multiplication is differentiable, then the inversion is also differentiable.

- 2) Consider the group  $GL_n(\mathbb{H})$  of invertible  $n \times n$  matrices over  $\mathbb{H}$  as an open subset of the real vector space of all quaternionic  $n \times n$  matrices. Show that  $GL_n(\mathbb{H})$  thus endowed with a differentiable manifold structure is a real Lie group of dimension  $4n^2$ .
- 3) The group  $Sp_n$  of unitary quaternionic matrices is a Lie subgroup of dimension  $2n^2 + n$  in  $GL_n(\mathbb{H})$ .
- 4) Find all the Lie subgroups of the additive Lie group  $K$ .
- 5) Any homomorphism  $f$  of the additive Lie group  $K$  into  $GL_n(K)$  is of the form  $f(t) = \exp(tX)$ , where  $X \in L_n(K)$ .
- 6) The centralizer  $Z(g)$  of any element  $g$  of a Lie group  $G$  is a Lie subgroup.
- 7) The dimension of the centralizer of any element of  $GL_n(K)$  is not less than  $n$ .
- 8) The Lie group  $Sp_n$  (see Exercise 3) is compact.
- 9) The action of  $GL_n(K)$  on  $Gr_{n,p}(K)$  is differentiable.
- 10) Let  $W \subset U$  be subspaces of a vector space  $V$  over  $K$ . Let  $H$  be a Lie subgroup of  $GL(U/W)$ . Then the set of invertible linear transformations of  $V$  preserving  $U$  and  $W$  and inducing on  $U/W$  transformations from the group  $H$  is a Lie subgroup in  $GL(V)$ .
- 11) The Lie group  $GL_n(K)$  splits into the semidirect product of  $SL_n(K)$  and a one-dimensional Lie subgroup.

**Hints to Problems**

3. Note that the left translation by any element of  $H$  is an  $H$ -preserving diffeomorphism of the manifold  $G$ .
7. As any submanifold, the Lie subgroup  $H$  is open in its closure  $\bar{H}$ . If  $g \in \bar{H}$ , then  $gH$  is also open in  $\bar{H}$ , hence intersects with  $H$ , and therefore  $g \in H$ .
9. Compute the matrix elements of the representations  $R + S$ ,  $RS$  and  $R^*$  in convenient bases. For example, if  $\{e_i\}$  is a basis of the space  $V$  and  $\{f_j\}$  is a basis of  $U$  then  $\{e_i \otimes f_j\}$  is a basis of  $V \otimes U$ . The matrix elements of the representation  $RS$  in this basis are products of matrix elements of the representations  $R$  and  $S$ .
10. It suffices to prove these formulas for simple tensors  $f$  and  $F$ , respectively.
11. It suffices to look at the action of  $Ad(A)$  and  $Sq(A)$  on simple tensors (corresponding to matrices of rank 1).
12. Use the commutative diagram

$$\begin{array}{ccc}
 G & \xrightarrow{\alpha_x} & X \\
 \downarrow l(g) & & \downarrow \alpha(g) \\
 G & \xrightarrow{\alpha_x} & X
 \end{array}$$

13. It suffices to show that the orbit  $\alpha(G)x$  is a submanifold in a neighbourhood of  $x$ . Let  $\mathcal{O}(e)$  be a neighbourhood of the unit of  $G$  such that  $U = \alpha(\mathcal{O}(e))x$  is

a submanifold in  $X$ . The orbit  $\alpha(G)x$  is the union of the two nonintersecting subsets:  $U$  and  $\alpha(C)x$ , where  $C = G \setminus \mathcal{O}(e)G_x$ . Since  $\mathcal{O}(e)G_x = \bigcup_{g \in G_x} \mathcal{O}(e)g$  is open in  $G$ , its complement,  $C$ , is closed and therefore compact; but then  $\alpha(C)x = \alpha_x(C)$  is compact, hence closed in  $X$ . Thus the intersection of  $\alpha(G)x$  with the open subset  $X \setminus \alpha(C)x$  of  $X$  containing  $x$  is a submanifold.

14. Suppose  $a_n \neq 0$ . The intersection of the subgroup  $f(\mathbb{R})$  with the subgroup

$$\mathbb{T}^{n-1} = \{(z_1, \dots, z_n) \in \mathbb{T}^n : z_n = 1\}$$

is a cyclic group with generator

$$t = (e^{2\pi i(a_1/a_n)}, \dots, e^{2\pi i(a_{n-1}/a_n)}, 1).$$

If at least one of  $a_1/a_n, \dots, a_{n-1}/a_n$  is irrational, then  $t$  is an element of infinite order, and  $f(\mathbb{R}) \cap \mathbb{T}^{n-1}$  is not closed in  $\mathbb{T}^{n-1}$ . But then  $f(\mathbb{R})$  is not closed in  $\mathbb{T}^n$ , hence is not a Lie subgroup (see Problem 7).

Conversely, suppose  $a_1, \dots, a_n$  are commensurable. Let us assume that not all of them are zero. Then  $\text{Ker } f = b\mathbb{Z}$ , where  $b > 0$ . Let  $U$  be a neighbourhood of the origin of  $\mathbb{R}$  such that  $f(U)$  is a submanifold in  $\mathbb{T}^n$ . The complement of the open submanifold  $U + b\mathbb{Z}$  in  $\mathbb{R}$  will be denoted by  $C$ . Since  $f(C) = f(C \cap [0, b])$  and since  $C \cap [0, b]$  is compact,  $f(C)$  is closed in  $\mathbb{T}^n$ . The complement of  $f(C)$  is open and contains the unit of  $\mathbb{T}^n$ ; the intersection of  $f(\mathbb{R})$  with this open set coincides with  $f(U)$ . Hence,  $f(\mathbb{R})$  is a Lie subgroup (see Problem 3).

18. Let  $g_1H$  and  $g_2H$  be different cosets. Then  $g_1^{-1}g_2 \notin H$ . Since the group operations are continuous and  $H$  is closed (Problem 7), there are neighbourhoods  $\mathcal{O}(g_1)$  and  $\mathcal{O}(g_2)$  of  $g_1$  and  $g_2$ , respectively, such that  $\mathcal{O}(g_1)^{-1}\mathcal{O}(g_2) \cap H = \emptyset$ . Then  $\mathcal{O}(g_1)H \cap \mathcal{O}(g_2)H = \emptyset$ . Hence  $p(\mathcal{O}(g_1))$  and  $p(\mathcal{O}(g_2))$  are nonintersecting neighbourhoods of the cosets  $g_1H$  and  $g_2H$  in the space  $G/H$ .

19. Let  $S_1$  be a submanifold transversal to  $H$  at the point  $e$ , i.e. such that

$$T_e(G) = T_e(H) \oplus T_e(S_1).$$

Since

$$d_{(e,e)}\nu(ds, dh) = ds + dh,$$

then  $d_{(e,e)}\nu$  is an isomorphism of the tangent spaces. Hence, there exist neighbourhoods  $S_2$  and  $\mathcal{O}_H(e)$  of the point  $e$  in the manifolds  $S_1$  and  $H$ , respectively, such that  $\nu$  diffeomorphically maps  $S_2 \times \mathcal{O}_H(e)$  onto an open subset of  $G$ . Since  $\nu(s, hh') = \nu(s, h)h'$ , the mapping  $\nu$  is a local diffeomorphism everywhere on  $S_2 \times \mathcal{O}_H(e)$ . Let  $S$  be a neighbourhood of  $e$  in  $S_2$  such that  $S^{-1}S \cap H \subset \mathcal{O}_H(e)$ . Then  $\nu$  is locally diffeomorphic and injective on  $S \times H$ , thus  $S$  is the desired submanifold.

21. Con

where  
and  
22. App  
23. App  
 $H_2$   
24. App

It is  
  
Her

25. App  
  
It is  
L(V

Her

1°. E  
neighb  
space T

21. Consider the commutative diagram

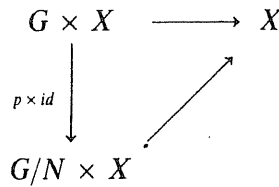

where the horizontal arrow is the map defined by the given  $G$ -action on  $X$  and use the fact that  $p \times id$  is a quotient map.

- 22. Apply Problem 21 to the canonical  $G$ -action on  $G/H$ .
- 23. Apply Theorem 6 to the identity embedding  $H_1 \hookrightarrow G$  and the subgroup  $H_2 \subset G$ .
- 24. Apply Theorem 6 to the homomorphism  $R$  and the subgroup

$$GL(V; U) = \{A \in GL(V) : AU \subset U\} \subset GL(V).$$

It is easy to see that  $GL(V; U)$  is an open subset in the space

$$L(V; U) = \{X \in L(V) : XU \subset U\}.$$

Hence,  $GL(V; U)$  is a linear Lie group and

$$T_E(GL(V; U)) = L(V; U).$$

25. Apply Theorem 6 to the homomorphism  $R$  and the subgroup

$$GL(V; U, W) = \{A \in GL(V) : (A - E)U \subset W\} \subset GL(V).$$

It is easy to see that  $GL(V; U, W)$  is an open subset in the plane  $E + L(V; U, W)$ , where

$$L(V; U, W) = \{X \in L(V) : XU \subset W\}.$$

Hence,  $GL(V; U, W)$  is a linear Lie group and

$$T_E(GL(V; U, W)) = L(V; U, W).$$

## § 2. Tangent Algebra

**1°. Definition of the Tangent Algebra.** The structure of a Lie group in a neighbourhood of the unit is determined by an algebra structure in the tangent space  $T_e(G)$ . The most straightforward way to define it is the following one.

Choose a coordinate system in a neighbourhood of the unit  $e$  of  $G$  such that all the coordinates of the point  $e$  are zero. The column of coordinates of a point  $x$  will be denoted by  $\bar{x}$ . Consider the Taylor series expansion of the coordinates of the product  $xy$ . Since  $ey = y$  and  $xe = x$ , we have

$$\overline{xy} = \bar{x} + \bar{y} + \alpha(\bar{x}, \bar{y}) + \cdots \quad (1)$$

where  $\alpha$  is a bilinear vector-valued function and dots stand for the terms of degree  $\geq 3$ .

The transposition of  $x$  and  $y$  yields

$$\overline{yx} = \bar{y} + \bar{x} + \alpha(\bar{y}, \bar{x}) + \cdots \quad (2)$$

We see that the noncommutativity of the multiplication in  $G$  can only manifest itself in terms of degree  $\geq 2$ . The noncommutativity is measured by the group commutator  $(x, y) = xyx^{-1}y^{-1}$ . The second order terms in the Taylor series expansion of coordinates of  $(x, y)$  are easy to find from the relation  $(x, y)yx = xy$ . Comparing (1) and (2) we get

$$\overline{(x, y)} = \gamma(\bar{x}, \bar{y}) + \cdots, \quad (3)$$

where

$$\gamma(\bar{x}, \bar{y}) = \alpha(\bar{x}, \bar{y}) - \alpha(\bar{y}, \bar{x}), \quad (4)$$

and dots stand for the terms of degree  $\geq 3$ .

In the tangent space  $T_e(G)$ , define a bilinear operation known as the *bracket* or *commutator*  $(\xi, \eta) \mapsto [\xi, \eta]$  by the formula

$$[\bar{\xi}, \bar{\eta}] = \gamma(\bar{\xi}, \bar{\eta}), \quad (5)$$

where  $\bar{\xi}$  is the column of coordinates of a tangent vector  $\xi$  in the coordinate system of  $T_e(G)$  associated with the chosen local coordinate system on  $G$ . Let us prove that this operation does not depend on the choice of the coordinate system.

Consider another local coordinate system with the origin at  $e$ . The column of coordinates of  $x$  in the new coordinate system will be denoted by  $\bar{\bar{x}}$ . Then

$$\bar{x} = C\bar{\bar{x}} + \cdots,$$

where  $C$  is the Jacobi matrix of the old coordinates with respect to the new ones at  $e$  and dots stand for the terms of degree  $\geq 2$ . Hence,

$$\overline{(x, y)} = C^{-1}\gamma(C\bar{\bar{x}}, C\bar{\bar{y}}) + \cdots, \quad (6)$$

where dots stand for the terms of degree  $\geq 3$ .

such that  
of a point  
ordinates

The coordinates of a tangent vector  $\xi \in T_e(G)$  are transformed via the formula

$$\bar{\xi} = C\xi,$$

hence

$$(1) \quad \overline{[\xi, \eta]} = C^{-1}\gamma(C\xi, C\eta). \quad (7)$$

of degree

Here  $[\bar{\xi}, \bar{\eta}]$  stands for the bracket defined in the old coordinate system. Formulas (6) and (7) show that  $[\bar{\xi}, \bar{\eta}]$  coincides with the bracket of  $\xi$  and  $\eta$  defined in the new coordinate system.

(2)

The space  $T_e(G)$  endowed with the above defined bracket  $e$  is called the *tangent algebra of the Lie group  $G$*  and is denoted by  $\mathfrak{g}$ . In the sequel we also denote Lie groups by Latin capitals and the corresponding tangent algebras by the corresponding small Gothic letters.

manifest  
he group  
lor series  
)yx = xy.

It is clear (see formula (4)) that the tangent algebra is anticommutative, i.e.

$$[\xi, \eta] = -[\eta, \xi]$$

for any  $\xi, \eta \in \mathfrak{g}$ .

(3)

**Problem 1.** The tangent algebra of a commutative Lie group is an algebra with the zero bracket.

(4)

Let  $V$  be a finite dimensional vector space over  $K$ . We will naturally identify the tangent space of the Lie group  $GL(V)$  at  $E$  with the space  $L(V)$ .

**Problem 2.** The tangent algebra of  $GL(V)$  is the space  $L(V)$  with the bracket

e bracket

$$[\mathcal{X}, \mathcal{Y}] = \mathcal{X}\mathcal{Y} - \mathcal{Y}\mathcal{X}. \quad (8)$$

The tangent algebra of  $GL(V)$  (resp.  $GL_n(K)$ ) is denoted by  $\mathfrak{gl}(V)$  (resp.  $\mathfrak{gl}_n(K)$ ).

(5)

**2°. Tangent Homomorphism.** Let  $f: G \rightarrow H$  be a Lie group homomorphism. Let  $d_e f: T_e G \rightarrow T_e H$  be its differential at  $e$ .

ordinate  
G. Let us  
te system  
olumn of  
hen

**Problem 3.** The map  $d_e f$  is a homomorphism of tangent algebras.

We will sometimes call the map  $d_e f$  the *tangent homomorphism* of  $f$  and, by an abuse of notation denote it simply by  $df$ .

**Problem 4.** The tangent algebra of a Lie subgroup of a Lie group  $G$  is a subalgebra of the tangent algebra  $\mathfrak{g}$ . In particular, the bracket in the tangent algebra of any linear Lie group is defined by the formula (8).

new ones

By Theorem 1.2 the tangent algebra of the kernel of a Lie group homomorphism coincides with the kernel of the tangent homomorphism.

For example, the kernel of the homomorphism

(6)

$$\det: GL_n(K) \rightarrow K^*.$$

is  $SL_n(K)$ .

**Problem 5.**  $(d_E \det)(X) = \text{tr } X$ .

Thus, the tangent algebra of  $SL_n(K)$  consists of all traceless matrices. It is denoted by  $\mathfrak{sl}_n(K)$ .

**Problem 6.** Let  $H$  be a normal subgroup of  $G$ . Then  $\mathfrak{h}$  is an ideal of  $\mathfrak{g}$  and, under the canonical identification of the tangent space  $T_e(G/H)$  with the quotient space  $T_e(G)/T_e(H)$  the tangent algebra of  $G/H$  coincides with  $\mathfrak{g}/\mathfrak{h}$ .

A particular case of the tangent homomorphism is the differential of a linear representation. The differential of a representation  $G \rightarrow GL(V)$  is a homomorphism  $\mathfrak{g} \rightarrow \mathfrak{gl}(V)$ .

**Problem 7.** The differentials of the linear representations  $\text{Ad}$  and  $\text{Sq}$  defined in Problem 1.8 are of the form

$$(d \text{Ad})(Y)(X) = YX - XY, \quad (d \text{Sq})(Y)(X) = YX + XY'.$$

Let  $R$  and  $S$  be linear representations of a Lie group  $G$  in spaces  $V$  and  $U$ , respectively, and let  $dR$  and  $dS$  be their differentials. Let us compute the differentials of  $R^*$  and  $RS$ .

**Problem 8.**  $((dR^*)(\xi)f)(v) = -f((dR)(\xi)v)$ .

**Problem 9.**  $(d(RS))(\xi)(v \otimes u) = (dR(\xi))v \otimes u + v \otimes (dS(\xi))u$ .

Using these formulas we may compute the differential of the product of any number of given linear representations and their duals.

For example, the natural linear representation  $T_{k,l}$  of  $GL(V)$  in the space of tensors of type  $(k,l)$  is the product of  $k$  copies of the identity representation and  $l$  copies of its dual (see 1.4). Denote the differential of  $T_{k,l}$  by  $\tau_{k,l}$ . Let us give convenient formulas for  $\tau_{0,l}(X)$  and  $\tau_{1,l}(X)$ , where  $X \in \mathfrak{gl}(V)$ .

If  $f$  is an  $l$ -linear function on  $V$  then

$$(\tau_{0,l}(X)f)(v_1, \dots, v_l) = -\sum_i f(v_1, \dots, v_{i-1}, Xv_i, v_{i+1}, \dots, v_l). \quad (9)$$

If  $F: V \times \dots \times V \rightarrow V$  ( $l$  factors in the source) is a multilinear map then

$$(\tau_{1,l}(X)F)(v_1, \dots, v_l) = XF(v_1, \dots, v_l) - \sum_i F(v_1, \dots, v_{i-1}, Xv_i, v_{i+1}, \dots, v_l). \quad (10)$$

**Problem 10.** Prove formulas (9) and (10).

**3°. The Tangent Algebra of a Stabilizer.** When a Lie subgroup  $H$  of  $G$  is defined as the stabilizer of a certain point for some  $G$ -action, the tangent subalgebra corresponding to  $H$  may be found using Theorem 1.1.

Consider the case of a linear action  $R: G \rightarrow GL(V)$ . The differentiation of the identity  $R_v(g) = R(g)v$  with respect to  $g$  at  $e$  gives

$$(dR_v)(\xi) = (dR)(\xi)v,$$

where  $dR$  on the right-hand side stands for the differential of  $R$ . Therefore, the second part of heading 1) of Theorem 1.1 can be reformulated in this particular case as follows.

**Theorem 1.** *Suppose  $R$  is a linear representation of  $G$  in  $V$  and  $H$  is the stabilizer of  $v \in V$ . Then*

$$\mathfrak{h} = \{ \xi \in \mathfrak{g} : dR(\xi)v = 0 \}.$$

In particular, using this theorem we can find the tangent algebra of a linear Lie group that preserves a tensor.

*Examples.* 1) The group  $G$  of invertible linear transformations of a space  $V$  that preserve a fixed bilinear form  $f$  is the stabilizer of  $f$  with respect to the natural linear representation  $T_{0,2}$  of  $GL(V)$  in the space of bilinear forms on  $V$  (see formula 1.1). Formula (9) implies that the tangent algebra of  $G$  consists of all linear maps which are skew-symmetric with respect to  $f$ .

2) Let  $A$  be a finite-dimensional algebra over  $K$ . The group  $\text{Aut } A$  of the automorphisms of  $A$  is the stabilizer of the structure tensor of  $A$  with respect to the natural linear representation  $T_{1,2}$  of  $GL(A)$  in the space of tensors of type  $(1, 2)$  on  $A$  (see formula (1.2)). Formula (10) implies that the tangent algebra of  $\text{Aut } A$  consists of all linear transformations  $D$  that satisfy

$$D(ab) = D(a)b + aD(b), \quad (a, b \in A) \tag{11}$$

Such transformations are called *derivations* of  $A$ . Hence, they form an algebra with respect to the bracket. (This, however, may be verified directly.) This algebra is denoted by  $\text{Der } A$ .

**4°. The Adjoint Representation and the Jacobi Identity.** Any Lie group  $G$  has a natural linear representation in its tangent algebra  $\mathfrak{g}$ . It is defined as follows:

For any  $g \in G$  consider the inner automorphism

$$a(g): x \mapsto gxg^{-1}, \quad \text{where } x \in G.$$

Denote by  $\text{Ad } g$  the differential of  $a(g)$  at  $e$ . It is an automorphism of the tangent algebra.

**Problem 11.** The map  $\text{Ad}: G \rightarrow GL(\mathfrak{g})$  is a linear representation of the Lie group  $G$ .

$\text{Ad}$  is called the *adjoint representation* of  $G$ . Let us compute the corresponding tangent homomorphism  $\mathfrak{g} \rightarrow \mathfrak{gl}(\mathfrak{g})$ .

**Problem 12.** In local coordinates in a neighbourhood of the unit we have

$$\overline{gxg^{-1}} = \bar{x} + \gamma(\bar{g}, \bar{x}) + \dots,$$

where dots stand for the terms of degree  $\geq 3$ .

If we confine ourselves to terms of the first degree in  $\bar{x}$  we obtain

$$\overline{(\text{Ad } g)\xi} = \bar{\xi} + \gamma(\bar{g}, \bar{\xi}) + \dots,$$

where dots stand for the terms of degree  $\geq 2$  in  $\bar{g}$ . This implies that

$$\overline{(d \text{Ad}(\eta))\xi} = \gamma(\bar{\eta}, \bar{\xi}),$$

i.e.

$$(d \text{Ad})(\xi)\eta = [\xi, \eta] \quad (\xi, \eta \in \mathfrak{g}) \quad (12)$$

Since  $d \text{Ad}$  is a Lie algebra homomorphism  $\mathfrak{g} \rightarrow \mathfrak{gl}(\mathfrak{g})$ , we have

$$[[\xi, \eta], \zeta] = [\xi, [\eta, \zeta]] - [\eta, [\xi, \zeta]] \quad (13)$$

for any  $\xi, \eta, \zeta \in \mathfrak{g}$ . Taking into account the anticommutativity of the bracket we may rewrite this identity in a more symmetric form:

$$[[\xi, \eta], \zeta] + [[\eta, \zeta], \xi] + [[\zeta, \xi], \eta] = 0 \quad (14)$$

The identity (14) is called the *Jacobi identity*.

**Problem 13.** Prove the Jacobi identity starting from

$$\text{Ad } G \subset \text{Aut } \mathfrak{g}.$$

An anticommutative algebra that satisfies the Jacobi identity is called a *Lie algebra*<sup>2</sup>. We have proved

**Theorem 2.** *The tangent algebra of any Lie group is a Lie algebra.*

In particular,  $\mathfrak{gl}(V)$  is a Lie algebra. This however is easy to deduce directly from (8).

A Lie algebra homomorphism  $\mathfrak{g} \rightarrow \mathfrak{gl}(V)$  is called a *linear representation* of  $\mathfrak{g}$ . By Problem 3 the differential of a linear representation of a Lie group is a linear representation of its tangent algebra.

The Jacobi identity written in the form (13) means that for any Lie algebra  $\mathfrak{g}$  the map  $\text{ad}: \mathfrak{g} \rightarrow \mathfrak{gl}(\mathfrak{g})$  defined by the formula

$$(\text{ad } \xi)\eta = [\xi, \eta] \quad (\xi, \eta \in \mathfrak{g}),$$

is a linear representation of  $\mathfrak{g}$ . This representation is called the *adjoint representation* of  $\mathfrak{g}$ . We have proved (formula (12)) the following statement:

<sup>2</sup> When the ground field is of characteristic 2 the anticommutativity should be replaced by a stronger condition: " $[\xi, \xi] = 0$  for all  $\xi \in \mathfrak{g}$ ".

**Theorem 3.** *The differential of the adjoint representation of a Lie group coincides with the adjoint representation of its tangent algebra.*

A Lie algebra with the zero bracket is called *commutative*. By Problem 1 the tangent algebra of a commutative Lie group is commutative.

**5°. Differential Equations for Paths on a Lie Group.** By means of left or right translations we may define natural isomorphisms between tangent spaces to the Lie group  $G$  at different points. Let  $l(g)$  be a left translation by  $g \in G$ , i.e. the transformation  $x \mapsto gx$ , and  $r'(g)$  the right translation by  $g$ , i.e. the transformation  $x \mapsto xg$ . For any  $\xi \in T_h(G)$  put

$$g\xi = dl(g)(\xi) \in T_{gh}(G),$$

$$\xi g = dr'(g)(\xi) \in T_{hg}(G).$$

In particular, if  $\xi \in \mathfrak{g}$  then  $g\xi, \xi g \in T_g(G)$ .

Evidently, if  $G \subset GL(V)$  is a linear Lie group and its tangent spaces at different points are naturally embedded into  $L(V)$ , then  $g\xi$  and  $\xi g$  are the usual products of linear transformations.

**Problem 14.** Let  $G$  be a Lie group. Then

$$(gh)\xi = g(h\xi), \quad (g\xi)h = g(\xi h), \quad (\xi g)h = \xi(gh)$$

for any  $g, h \in G, \xi \in \mathfrak{g}$ .

Also, note that by the definition of the adjoint representation we have

$$g\xi g^{-1} = (\text{Ad } g)\xi \quad (\xi \in \mathfrak{g})$$

**Problem 15.** Suppose a coordinate system with the origin at the unit  $e$  of a Lie group  $G$  is chosen in a neighbourhood of  $e$ . This naturally determines coordinate systems on the tangent spaces. Then the Taylor series expansions of coordinates of "products"  $g\xi$  and  $\xi g$ , where  $\xi \in \mathfrak{g}$ , are of the form

$$\overline{g\xi} = \bar{\xi} + \alpha(\bar{g}, \bar{\xi}) + \dots,$$

$$\overline{\xi g} = \bar{\xi} + \alpha(\bar{\xi}, \bar{g}) + \dots,$$

where  $\alpha$  is the bilinear vector-valued function from formula (1) and dots stand for the terms linear in  $\bar{\xi}$  and of degree  $\geq 2$  in  $\bar{g}$ .

**Problem 16.** Let  $f: G \rightarrow H$  be a Lie group homomorphism. Then

$$df(g\xi) = f(g)df(\xi)$$

$$df(\xi g) = df(\xi)f(g)$$

for any  $g \in G$  and  $\xi \in T(G)$ .

One of the constructed parametrizations of tangent spaces of a Lie group  $G$  with the elements of the tangent algebra  $\mathfrak{g}$  may be used to describe the differentiable paths in  $G$  in terms of  $\mathfrak{g}$ . This description will play an important role in the remainder of this section.

A continuous map of a connected subset of the real line into the manifold  $X$  is called a *path* in  $X$ .

For any differentiable path  $t \mapsto g(t)$  in a Lie group  $G$  define a path  $t \mapsto \xi(t)$  in the Lie algebra  $\mathfrak{g}$  of  $G$  by the equation

$$\frac{dg(t)}{dt} = \xi(t)g(t). \quad (15)$$

The path  $\xi(t)$  is called the *velocity* of the path  $g(t)$ .

A velocity  $\xi(t)$  being given, equation (15) may be considered as a differential equation for  $g(t)$ . Written in local coordinates it is of the form

$$\frac{d\bar{g}(t)}{dt} = F(\bar{\xi}(t), \bar{g}(t)), \quad (16)$$

where  $\bar{g}(t)$  and  $\bar{\xi}(t)$  are the columns of coordinates of the elements  $g(t) \in G$  and  $\xi(t) \in \mathfrak{g}$ , respectively, and  $F$  is a differentiable vector-valued function, that depends only on the chosen coordinate system on  $G$  and on the coordinate system on  $\mathfrak{g}$ .

The uniqueness theorem for a system of ordinary differential equations implies that the velocity  $\xi(t)$  and the initial value  $g(t_0) = g_0$  uniquely determine the curve  $g(t)$ . The latter relation in Problem 14 shows that the set of solutions of (15) is invariant with respect to right translations. Since we can obtain any initial value by an appropriate right translation, any two solutions of (15) are obtained from each other by a right translation.

Let us now discuss the existence of a solution of (15).

**Proposition 1.** *Let  $t \mapsto \xi(t)$  be a differentiable map of a connected subset  $S \subset \mathbb{R}$  into the tangent algebra of a Lie group  $G$ . Then there exists a solution of (15) defined for all  $t \in S$ .*

*Proof.* Clearly, it suffices to prove the proposition in the case when  $S$  is a segment. Furthermore, it suffices to show that there exists  $\varepsilon > 0$  such that for any  $t_0 \in S$  there exists a solution of (15) defined for  $|t - t_0| < \varepsilon$ . Since the set of solutions is invariant with respect to right translations, we may assume that  $g(t_0) = e$ . Choose a coordinate system in a neighbourhood  $\mathcal{O}(e)$  of the unit of  $G$ , which sends the unit to zero. Let  $R$  be a positive number such that the neighbourhood  $\mathcal{O}(e)$  in the local coordinate system contains the ball  $\|x\| < R$ . (Here  $\|x\|$  stands for the Euclidean norm of the column-vector  $x$ ). Choose a coordinate system in the tangent algebra  $\mathfrak{g}$  and put  $C = \max_{t \in S} \|\xi(t)\|$ . Suppose that equation (15) in the above coordinate systems is of the form (16) and put

$$M = \max_{\|x\| \leq C, \|y\| \leq R} \|F(x, y)\|.$$

Then by the known existence theorem for a system of differential equations [43], equation (16) has a solution defined for  $|t - t_0| < R/M$  and  $t \in S$ . Since  $R/M$  does not depend on  $t_0$ , it may be taken as the desired  $\varepsilon$ .  $\square$

### 6°. Uniqueness Theorem for Lie Group Homomorphisms

**Theorem 4.** *A homomorphism of a connected Lie group  $G$  into a Lie group  $H$  is uniquely determined by the corresponding tangent homomorphism of Lie algebras.*

*Proof.* Let  $\varphi = df$  be the tangent homomorphism of the homomorphism  $f: G \rightarrow H$ . Let us show how  $f$  can be recovered from  $\varphi$ .

Let us join an arbitrary element  $g \in G$  with the unit by a differentiable path  $g(t)$ , where  $0 \leq t \leq 1$ . Let  $\xi(t)$  be the velocity of this path. Put  $h(t) = f(g(t))$ . Problem 16 implies that

$$\frac{dh(t)}{dt} = \varphi(\xi(t))h(t). \quad (17)$$

This relation may be considered as a differential equation for  $h(t)$ . Together with the initial condition  $h(0) = e$  it uniquely determines the path  $h(t)$  and therefore the element  $f(g) = h(1)$ .  $\square$

**Theorem 5.** *Let  $f$  be a homomorphism of a connected Lie group  $G$  into a Lie group  $H$ . Let  $H_1$  be a Lie subgroup of  $H$ . If  $df(\mathfrak{g}) \subset \mathfrak{h}_1$ , then  $f(G) \subset H_1$ .*

*Proof.* If  $\varphi(\mathfrak{g}) \subset \mathfrak{h}$  then equation (17) may be considered as an equation in the group  $H_1$ . Its solution in  $H_1$  is at the same time a solution in  $H$ . Hence,  $h(t) \in H_1$  for any  $t \in [0, 1]$  and, in particular,  $f(g) = h(1) \in H_1$ .  $\square$

Theorems 4 and 5 have plenty of important corollaries.

**Problem 17.** The kernel of the adjoint representation of a connected Lie group  $G$  coincides with the center  $Z(G)$  of  $G$ .

Define the *center* of a Lie algebra  $\mathfrak{g}$  to be the set  $\mathfrak{z}(\mathfrak{g}) = \{\zeta \in \mathfrak{g}: [\zeta, \xi] = 0 \text{ for any } \xi \in \mathfrak{g}\}$ .

**Problem 18.** The tangent algebra of the center of a connected Lie group  $G$  coincides with the center  $\mathfrak{z}(\mathfrak{g})$  of the tangent algebra  $\mathfrak{g}$ .

**Problem 19.** Let  $R$  be a linear representation of a connected Lie group  $G$  in a space  $V$ . A subspace  $U \subset V$  is invariant with respect to  $R$  if and only if it is invariant with respect to the tangent representation  $dR$  of the Lie algebra  $\mathfrak{g}$ .

**Problem 20.** Let  $G_1$  and  $G_2$  be connected Lie subgroups of  $G$ . Then

$$G_1 \subset G_2 \Leftrightarrow \mathfrak{g}_1 \subset \mathfrak{g}_2 \quad \text{and}$$

$$G_1 = G_2 \Leftrightarrow \mathfrak{g}_1 = \mathfrak{g}_2.$$

**Problem 21.** A connected Lie subgroup  $H$  of a connected Lie group  $G$  is normal if and only if its tangent algebra  $\mathfrak{h}$  is an ideal of  $\mathfrak{g}$ .

7°. **Exponential Map.** A differentiable path  $g(t)$  in a Lie group  $G$  defined for all  $t \in \mathbb{R}$  is called a *one-parameter subgroup* if

$$g(s + t) = g(s)g(t)$$

(and then we automatically have  $g(0) = e$  and  $g(-t) = g(t)^{-1}$ ).

In other words, a one-parameter subgroup is a homomorphism of the Lie group  $\mathbb{R}$  into  $G$ . Sometimes one defines a one-parameter subgroup to be the image of such a homomorphism. As Problem 1.14 shows a one-parameter subgroup in the latter sense may fail to be a Lie subgroup.

**Problem 22.** The path  $g(t)$  defined by the differential equation (15) is a one-parameter subgroup if and only if  $\xi(t) = \text{const}$  and  $g(0) = e$ .

For any  $\xi \in \mathfrak{g}$  put  $g_\xi(t)$  for the one-parameter subgroup defined by equation (15), where  $\xi(t) \equiv \xi$ . Call  $\xi$  its directing vector. For  $G = GL(V)$  it is known (and constitutes the theory of systems of linear differential equations with constant coefficients) that

$$g_\xi(t) = \exp(t\xi)$$

where the exponent is understood as the sum of the series

$$\exp X = \sum_{k \geq 0} \frac{X^k}{k!} \quad (X \in L(V)).$$

The same is obviously true for any linear Lie group. For an arbitrary Lie group  $G$  put

$$\exp(\xi) = g_\xi(1), \quad \text{where } \xi \in \mathfrak{g}.$$

The map  $\exp: \mathfrak{g} \rightarrow G$  thus defined is called the *exponential map*. Here are some of its properties.

**Problem 23.**  $g_\xi(t) = \exp(t\xi)$ .

**Problem 24.**  $\exp$  is differentiable.

**Problem 25.**  $d_0 \exp = \text{Id}$ .

This implies the following statement.

**Proposition 2.** The map  $\exp$  is a diffeomorphism of a neighbourhood of zero of the tangent algebra  $\mathfrak{g}$  onto a neighbourhood of the unit of  $G$ .

However at the global level, the exponential map does not possess, in general, any nice properties. It may be neither injective, nor onto, nor open, etc. (see Exercises 9 and 10).

**Problem 26.** Let  $f: G \rightarrow H$  be a Lie group homomorphism. Then

$$f(\exp(\xi)) = \exp(df(\xi)) \quad \text{for any } \xi \in \mathfrak{g}.$$

In particular,

$$\text{Ad exp } \xi = \exp \text{ ad } \xi \quad \text{for any } \xi \in \mathfrak{g}.$$

As an example consider the homomorphism  $\det: \text{GL}_n(K) \rightarrow K^*$ . Since  $d(\det) = \text{tr}$  (Problem 5), we have

$$\det \exp A = e^{\text{tr } A}$$

for any  $A \in L_n(K)$ .

**Problem 27.** If  $[\xi, \eta] = 0$  then  $\exp(\xi + \eta) = \exp \xi \cdot \exp \eta$ .

In particular, if  $G$  is a commutative Lie group then the same applies to any  $\xi, \eta \in \mathfrak{g}$ , i.e.  $\exp$  is a homomorphism of the vector group  $\mathfrak{g}$  into  $G$ . Proposition 2 implies that the kernel of this homomorphism is discrete and its image is an open subgroup of  $G$ . This can be used to classify the connected commutative Lie groups.

**Problem 28.** If  $G$  is a connected commutative Lie group then  $\exp \mathfrak{g} = G$ . Therefore, any  $n$ -dimensional connected commutative Lie group over  $K$  is isomorphic to  $K^n/\Gamma$ , where  $\Gamma$  is a discrete subgroup of  $K^n$ .

**Problem 29.** If  $G_1$  and  $G_2$  are isomorphic commutative Lie groups then there exists an isomorphism of their tangent algebras which maps the kernel of the homomorphism  $\exp: \mathfrak{g}_1 \rightarrow G_1$  into the kernel of the homomorphism  $\exp: \mathfrak{g}_2 \rightarrow G_2$ .

Therefore, if  $\Gamma_1$  and  $\Gamma_2$  are two discrete subgroups of  $K^n$  then the groups  $K^n/\Gamma_1$  and  $K^n/\Gamma_2$  are isomorphic (as Lie groups) if and only if  $\Gamma_1$  can be transformed into  $\Gamma_2$  by a nondegenerate linear transformation of  $K^n$ .

When  $K = \mathbb{R}$  there is a simple classification of discrete subgroups of  $K^n$ :

**Problem 30.** Any discrete subgroup  $\Gamma$  of the vector Lie group  $\mathbb{R}^n$  is transformed by a nondegenerate linear transformation into a subgroup of the form

$$\Gamma_k = \{(x_1, \dots, x_n) \in \mathbb{R}^n: x_1, \dots, x_k \in \mathbb{Z}, x_{k+1} = \dots = x_n = 0\}$$

This implies

**Proposition 3.** Any  $n$ -dimensional connected commutative real Lie group is isomorphic to a Lie group of the form  $\mathbb{T}^k \times \mathbb{R}^{n-k}$ .

When  $K = \mathbb{C}$  the classification of connected commutative Lie groups is considerably more complicated (see Exercises 12 and 13).

Let us demonstrate one more application of the exponential map.

**Problem 31.** Let  $\sigma$  be automorphism of a Lie group  $G$ . Then

$$G^\sigma = \{g \in G: \sigma(g) = g\}$$

is a Lie subgroup with the tangent algebra

$$\mathfrak{g}^\sigma = \{\xi \in \mathfrak{g}: d\sigma(\xi) = \xi\}.$$

### 8°. Existence Theorem for Lie Group Homomorphisms

**Theorem 6.** Let  $G$  and  $H$  be Lie groups and let  $G$  be simply connected. Then for any Lie algebra homomorphism  $\varphi: \mathfrak{g} \rightarrow \mathfrak{h}$  there exists a Lie group homomorphism  $f: G \rightarrow H$  such that  $df = \varphi$ .

*Proof.* Let us try to construct  $f$  following the lines of the proof of Theorem 4. Namely, in order to define the image of an element  $g \in G$  let us connect it with the unit by a differential path  $g(t)$ , where  $0 \leq t \leq 1$ , and find the velocity  $\xi(t)$  of this path. Furthermore, consider a solution  $h(t)$  of equation (17) with the initial value  $h(0) = e$ . Set  $f(g) = h(1)$ .

Since there is an arbitrariness in the choice of  $g(t)$ , we must prove that  $f(g)$  is well defined. This constitutes the bulk of the proof of the theorem.

We will use the fact that in a simply connected differentiable manifold  $X$  for any two differentiable paths  $\alpha_0$  and  $\alpha_1$  that join some points  $x_0$  and  $x_1$  there is a differentiable homotopy of  $\alpha_0$  into  $\alpha_1$ , i.e. a differentiable map of the square

$$I^2 = \{(t_1, t_2) \in \mathbb{R}^2: 0 \leq t_1, t_2 \leq 1\}$$

into  $X$  such that the bottom line is transformed into  $\alpha_0$  and the top line is transformed into  $\alpha_1$ , while the side lines are transformed into  $x_0$  and  $x_1$ , respectively.

**Lemma.** Let  $(t_1, t_2) \mapsto g(t_1, t_2)$  be a differentiable map of  $I^2$  into a Lie group  $G$ . Let

$$\begin{cases} \frac{\partial g(t, s)}{\partial t} = \xi(t, s)g(t, s) \\ \frac{\partial g(t, s)}{\partial s} = \eta(t, s)g(t, s), \end{cases} \quad (18)$$

where  $\xi(t, s), \eta(t, s) \in \mathfrak{g}$ . Then

$$\frac{\partial \eta(t, s)}{\partial t} - \frac{\partial \xi(t, s)}{\partial s} = [\xi(t, s), \eta(t, s)]. \quad (19)$$

*Proof of the lemma.* Since  $\xi(t, s)$  and  $\eta(t, s)$  do not change under the multiplication of  $g(t, s)$  on the right by any element of the group, then, proving (19) at a point  $(t_0, s_0)$  we may assume that  $g(t_0, s_0) = e$ .

Choose a coordinate system in a neighbourhood of the unit of  $G$  and write (18) in coordinates in a neighbourhood of  $(t_0, s_0)$ . By Problem 15 we get

$$\begin{cases} \frac{\partial \bar{g}(t, s)}{\partial t} = \bar{\xi}(t, s) + \alpha(\bar{\xi}(t, s), \bar{g}(t, s)) + \dots \\ \frac{\partial \bar{g}(t, s)}{\partial s} = \bar{\eta}(t, s) + \alpha(\bar{\eta}(t, s), \bar{g}(t, s)) + \dots, \end{cases}$$

where dots stand for the terms of degree  $\geq 2$  in  $(t - t_0, s - s_0)$ . The differentiation of the first of these equations with respect to  $s$  and of the second one with respect to  $t$  performed at  $(t_0, s_0)$  yields

$$\begin{aligned} \frac{\partial^2 \bar{g}(t_0, s_0)}{\partial t \partial s} &= \frac{\partial \bar{\xi}(t_0, s_0)}{\partial s} + \alpha(\bar{\xi}(t_0, s_0), \bar{\eta}(t_0, s_0)) \\ &= \frac{\partial \bar{\eta}(t_0, s_0)}{\partial t} + \alpha(\bar{\eta}(t_0, s_0), \bar{\xi}(t_0, s_0)), \end{aligned}$$

whence

$$\frac{\partial \bar{\eta}(t_0, s_0)}{\partial t} - \frac{\partial \bar{\xi}(t_0, s_0)}{\partial s} = \gamma(\bar{\xi}(t_0, s_0), \bar{\eta}(t_0, s_0)).$$

This means that

$$\frac{\partial \eta(t_0, s_0)}{\partial t} = \frac{\partial \xi(t_0, s_0)}{\partial s} = [\xi(t_0, s_0), \eta(t_0, s_0)].$$

The lemma is proved.  $\square$

Let us continue with the proof of theorem. Let  $g_0(t)$  and  $g_1(t)$  be two differentiable paths in  $G$  that join  $e$  with  $g$ . The corresponding paths in  $H$  obtained as the solutions of equation (17) will be denoted by  $h_0(t)$  and  $h_1(t)$ . We must show that  $h_0(1) = h_1(1)$ .

There is a differentiable map  $t \mapsto g(t, s)$  of the square  $I^2$  into  $G$  satisfying

1)  $g(t, 0) = g_0(t), g(t, 1) = g_1(t);$

2)  $g(0, s) = e, g(1, s) = g.$

Find  $\xi(t, s)$  and  $\eta(t, s)$  from equations (18). The property 2) implies that

$$\eta(0, s) = \eta(1, s) = 0.$$

Now, define the differentiable map  $(t, s) \mapsto h(t, s)$  of  $I^2$  into  $H$  as the solution of the initial value problem for the differential equation in  $t$  with  $s$  as a parameter:

$$\frac{\partial h(t, s)}{\partial t} = \varphi(\zeta(t, s))h(t, s), \quad h(0, s) = e.$$

Clearly,  $h(t, 0) = h_0(t)$  and  $h(t, 1) = h_1(t)$ .

Let

$$\frac{\partial h(t, s)}{\partial s} = \zeta(t, s)h(t, s),$$

where  $\zeta(t, s) \in \mathfrak{h}$ . Let us prove that  $\zeta(t, s) = \varphi(\eta(t, s))$ . This will imply that  $\zeta(1, s) = 0$ , hence  $h(1, s) = \text{const}$ . In particular, we get  $h_0(1) = h_1(1)$ .

By Lemma,

$$\frac{\partial \zeta(t, s)}{\partial t} = \frac{\partial \varphi(\xi(t, s))}{\partial s} + [\varphi(\xi(t, s)), \zeta(t, s)].$$

This relation may be considered as a differential equation (in  $t$ ) for  $\zeta(t, s)$ . Applying  $\varphi$  to (19) we obtain the same differential equation for  $\varphi(\eta(t, s))$ . Since

$$\zeta(0, s) = \varphi(\eta(0, s)) = 0,$$

$\zeta(t, s) = \varphi(\eta(t, s))$  for any  $t$ .

Thus, we have defined the mapping  $f: G \rightarrow H$ . Let us prove that  $f$  is a homomorphism.

Suppose  $g_1(t)$  and  $g_2(t)$ , where  $0 \leq t \leq 1$ , are differentiable paths in  $G$  that join  $e$  with  $g_1$  and  $g_2$ , respectively,  $\xi_1(t)$  and  $\xi_2(t)$  are their velocities. The path that connects  $e$  with  $g_1 g_2$  may be defined by

$$g(t) = \begin{cases} g_2(2t) & \text{for } 0 \leq t \leq 1/2 \\ g_1(2t - 1)g_2 & \text{for } 1/2 \leq t \leq 1. \end{cases}$$

Under an appropriate choice of paths  $g_1(t)$  and  $g_2(t)$  the path  $g(t)$  is differentiable. Its velocity  $\xi(t)$  is defined by

$$\xi(t) = \begin{cases} 2\xi_2(t) & \text{for } 0 \leq t \leq 1/2 \\ 2\xi_1(2t - 1) & \text{for } 1/2 \leq t \leq 1. \end{cases}$$

If  $h_1(t)$ ,  $h_2(t)$  and  $h(t)$  are paths in  $H$  corresponding to the paths  $g_1(t)$ ,  $g_2(t)$  and  $g(t)$ , then

$$h(t) = \begin{cases} h_2(2t) & \text{for } 0 \leq t \leq 1/2 \\ h_1(2t - 1)h_2(t) & \text{for } 1/2 \leq t \leq 1. \end{cases}$$

In particular,

$$f(g_1 g_2) = h(1) = h_1(1)h_2(1) = f(g_1)f(g_2).$$

From the construction of  $f$  we see that  $f(\exp(\xi)) = \exp \varphi(\xi)$  for any  $\xi \in \mathfrak{g}$ , i.e. the diagram

$$\begin{array}{ccc} \mathfrak{g} & \xrightarrow{\varphi} & \mathfrak{h} \\ \exp \downarrow & & \downarrow \exp \\ G & \xrightarrow{f} & H \end{array}$$

is commutative. Proposition 2 and Problem 25 show that  $f$  is differentiable in a neighbourhood of the unit of  $G$  and  $d_e f = \varphi$ . The homomorphism  $f$  is differentiable at any point  $g \in G$  because the diagram

$$\begin{array}{ccc} G & \xrightarrow{f} & H \\ l(g) \downarrow & & \downarrow l(h) \\ G & \xrightarrow{f} & H \end{array}$$

where  $h = f(g)$  is commutative. Theorem is proved.  $\square$

**Corollary.** *Simply connected Lie groups are isomorphic if and only if their tangent Lie algebras are isomorphic.*

**9°. Virtual Lie Subgroups.** As we have seen (Problem 1.14), the image of a Lie group under a homomorphism is not always a Lie subgroup. More general subgroups obtained in this way can sometimes serve as substitutes of Lie subgroups.

A *virtual Lie subgroup* of a Lie group  $G$  is a subgroup endowed with a Lie group structure so that the identity embedding  $i: H \rightarrow G$  is a Lie group homomorphism. We will assume that  $\mathfrak{h}$  is embedded into  $\mathfrak{g}$  via  $di$ .

Clearly, any Lie subgroup (endowed with the induced Lie subgroup structure) is a virtual Lie subgroup.

**Problem 32.** Let  $f: H \rightarrow G$  be an arbitrary Lie group homomorphism. Then the group  $f(H)$  endowed with a Lie group structure as the quotient group  $H/\text{Ker } f$  is a virtual Lie subgroup of  $G$  with the tangent algebra  $df(\mathfrak{h})$ .

The topology of a virtual Lie subgroup can be different from the topology induced by the ambient group. This is the case for a dense winding of the torus  $\mathbb{T}^2$  which carries the Lie group (in particular, the topology) structure of  $\mathbb{R}$  but intersects with any nonempty open subset of the torus on an unbounded subset of  $\mathbb{R}$ .

However, Theorem 1.2 implies that any sufficiently small neighbourhood  $\mathcal{O}_H(e)$  of the unit of a virtual Lie subgroup  $H$  is a submanifold of the ambient Lie group (in particular, possesses the induced topology) and  $T_e(\mathcal{O}_H(e)) = \mathfrak{h}$ .

The following problem elucidates the topological structure of virtual Lie subgroups.

**Problem 33.** Let  $H$  be a virtual Lie subgroup of  $G$ . There exists a neighbourhood  $\mathcal{O}_H(e)$  of the unit of  $H$  and a submanifold  $S \subset G$  containing the unit such that the map

$$v: S \times \mathcal{O}_H(e) \rightarrow G, \quad (s, h) \mapsto sh,$$

is a diffeomorphism of  $S \times \mathcal{O}_H(e)$  onto a neighbourhood  $\mathcal{O}_G(e)$  of the unit of  $G$  and

$$H \cap \mathcal{O}_G(e) = T\mathcal{O}_H(e),$$

where  $T = H \cap S$  is finite or countable. If  $\mathcal{O}_H(e)$  is connected, it is a connected component of  $H \cap \mathcal{O}_G(e)$  in the induced topology.

**Theorem 7.** Let  $G_1, G_2$  be virtual Lie subgroups of  $G$ . If  $G_1 \subset G_2$  then  $G_1$  is a virtual Lie subgroup of  $G_2$  and  $\mathfrak{g}_1 \subset \mathfrak{g}_2$ . Conversely, if  $\mathfrak{g}_1 \subset \mathfrak{g}_2$  and  $G_1$  is connected then  $G_1 \subset G_2$ .

**Problem 34.** Prove this theorem.

**Corollary 1.** If virtual Lie subgroups  $G_1, G_2$  of  $G$  coincide as subsets then they carry the same Lie group structure.

**Corollary 2.** A connected virtual Lie subgroup is uniquely determined by its tangent algebra (the subalgebra of the tangent algebra of the ambient Lie group).

Introducing virtual Lie subgroups makes the correspondence between Lie subgroups and subalgebras of the tangent algebra more complete. Namely, the following holds:

**Theorem 8.** Any subalgebra  $\mathfrak{h}$  of the tangent algebra of a Lie group  $G$  is the tangent algebra of a (uniquely determined) connected virtual Lie subgroup  $H$ .

Proof of this theorem will be given in n. 4.3.

There exists a simple topological characterization of Lie subgroups and virtual Lie subgroups of real Lie groups. By E. Cartan's theorem *any closed subgroup of a real Lie group is a Lie subgroup* (proof of this theorem can be found e.g. in [4] or [1]). Therefore Lie subgroups of real Lie groups are the same as closed subgroups.

*Any pathwise connected subgroup of a real Lie group is a virtual Lie subgroup* (Yamabe's theorem, see [40]). Therefore virtual Lie subgroups of a real Lie group are just the subgroups with a finite or countable number of pathwise connected components (in the induced topology).

**10°. Automorphisms and Derivations.** Let  $G$  be a connected Lie group and  $\text{Aut } G$  the group of its automorphisms (as of a Lie group).

Any group automorphism of  $G$  generates an automorphism of its tangent algebra  $\mathfrak{g}$ . If  $G$  is simply connected then the converse is true (Theorem 6); in this case  $\text{Aut } G$  is naturally isomorphic to  $\text{Aut } \mathfrak{g}$ , the automorphism group of the Lie algebra  $\mathfrak{g}$ . The latter group is a linear Lie group (Example 1.5.3). Therefore,  $\text{Aut } G$  is naturally endowed with a Lie group structure provided  $G$  is simply connected.

**Problem 35.** The action of the Lie group  $\text{Aut } G$  on a simply connected Lie group  $G$  is differentiable.

Similarly as for abstract groups, the inner automorphisms of a Lie group  $G$  constitute a normal subgroup of  $\text{Aut } G$  isomorphic to the quotient group  $G/Z$  (where  $Z$  is the center of  $G$ ) and denoted by  $\text{Int } G$ . Accordingly, their differentials  $\text{Ad } g$ ,  $g \in G$ , called the *inner automorphisms* of the Lie algebra  $\mathfrak{g}$ , constitute the normal subgroup of  $\text{Aut } \mathfrak{g}$ . This subgroup is denoted by  $\text{Int } \mathfrak{g}$ .

The quotient group  $\text{Aut } G/\text{Int } G$  (resp.  $\text{Aut } \mathfrak{g}/\text{Int } \mathfrak{g}$ ) is called the *group of outer automorphisms* of the Lie group  $G$ . (resp. Lie algebra  $\mathfrak{g}$ ). (Clearly, this term should not be understood literally. Moreover the outer, i.e. not inner, automorphisms do *not* constitute a group at all.) For a simply connected group  $G$  we have the natural isomorphism  $\text{Aut } G/\text{Int } G \simeq \text{Aut } \mathfrak{g}/\text{Int } \mathfrak{g}$ .

The group  $\text{Int } \mathfrak{g}$ , being the image of  $G$  under the adjoint representation, is a virtual Lie subgroup of  $\text{Aut } \mathfrak{g}$ . However, it might be not a genuine Lie subgroup: cf. Exercise 19.

The tangent algebra of  $\text{Aut } \mathfrak{g}$  is the Lie algebra  $\mathfrak{der } \mathfrak{g}$  of derivations of  $\mathfrak{g}$  (Example 3.2). The tangent algebra of  $\text{Int } \mathfrak{g}$  is the image of  $\mathfrak{g}$  under the homomorphism

$$\text{ad} = d\text{Ad}: \mathfrak{g} \rightarrow \mathfrak{der } \mathfrak{g}$$

This shows, in particular, (see Corollary 2 of Theorem 7) that  $\text{Int } \mathfrak{g}$  does not depend on the choice of  $G$  from connected Lie groups with the tangent algebra  $\mathfrak{g}$ .

The derivations of the form  $\text{ad } \xi$ ,  $\xi \in \mathfrak{g}$ , are called the *inner derivations* of the Lie algebra  $\mathfrak{g}$ .

**Problem 36.** The inner derivations constitute an ideal of  $\mathfrak{der } \mathfrak{g}$ . More precisely

$$[D, \text{ad } \xi] = \text{ad } D\xi \quad \text{for any } D \in \mathfrak{der } \mathfrak{g}, \xi \in \mathfrak{g}. \quad (20)$$

*Examples.* 1) If  $\mathfrak{g}$  is a commutative Lie algebra then

$$\text{Aut } \mathfrak{g} = \text{GL}(\mathfrak{g}), \quad \text{Int } \mathfrak{g} = \{E\}.$$

2) Let  $\mathfrak{g}$  be the Lie algebra of nil-triangular (triangular with zeroes on the diagonal)  $3 \times 3$  matrices. This is the tangent algebra of the Lie group of unitriangular  $3 \times 3$  matrices. For its basis take:

$$X = \begin{pmatrix} 0 & 1 & 0 \\ 0 & 0 & 0 \\ 0 & 0 & 0 \end{pmatrix}, \quad Y = \begin{pmatrix} 0 & 0 & 0 \\ 0 & 0 & 1 \\ 0 & 0 & 0 \end{pmatrix}, \quad Z = \begin{pmatrix} 0 & 0 & 1 \\ 0 & 0 & 0 \\ 0 & 0 & 0 \end{pmatrix},$$

with the commutation relations

$$[X, Y] = Z, \quad [X, Z] = [Y, Z] = 0.$$

The subspace  $\mathfrak{z} = \langle Z \rangle$  is the center of  $\mathfrak{g}$ . Any automorphism should transform  $\mathfrak{z}$  into itself, i.e. multiply  $Z$  by some  $c \neq 0$ . It is subject to a straightforward verification that such an automorphism induces in  $\mathfrak{g}/\mathfrak{z}$  a linear transformation with determinant  $c$ . Conversely, any linear transformation with these properties is an automorphism of  $\mathfrak{g}$ . The inner automorphisms are of the form

$$X \mapsto X + aZ, \quad Y \mapsto Y + bZ, \quad Z \mapsto Z \quad (a, b \in K).$$

The group  $\text{Int } \mathfrak{g}$  in this case is a Lie subgroup of  $\text{Aut } \mathfrak{g}$  and is isomorphic to the two-dimensional vector group. The quotient group  $\text{Aut } \mathfrak{g}/\text{Int } \mathfrak{g}$  (the group of outer automorphisms of  $\mathfrak{g}$ ) is isomorphic to  $\text{GL}_2(K)$ .

3) Let  $\mathfrak{g}$  be the Lie algebra of matrices of the form  $\begin{pmatrix} x & y \\ 0 & 0 \end{pmatrix}$ , where  $x, y \in K$ . This is the tangent algebra of the Lie group  $G$  of matrices of the form  $\begin{pmatrix} a & b \\ 0 & 1 \end{pmatrix}$ , where  $a, b \in K$ ,  $a \neq 0$ . The group  $G$  is isomorphic to the group of affine transformations of the line. For the basis of  $\mathfrak{g}$  take  $X = \begin{pmatrix} 1 & 0 \\ 0 & 0 \end{pmatrix}$ , and  $Y = \begin{pmatrix} 0 & 1 \\ 0 & 0 \end{pmatrix}$ , satisfying  $[X, Y] = Y$ . A straightforward calculation shows that the inner automorphism defined by  $\begin{pmatrix} a & b \\ 0 & 1 \end{pmatrix} \in G$  acts as follows:

$$X \mapsto X - bY, \quad Y \mapsto aY.$$

On the other hand, any automorphism of  $\mathfrak{g}$  is, clearly, of this form. Thus, in this case

$$\text{Aut } \mathfrak{g} = \text{Int } \mathfrak{g} \simeq G.$$

**11°. The Tangent Algebra of a Semidirect Product of Lie Groups.** To semidirect products of Lie groups there correspond *semidirect sums* of Lie algebras (which could as well have been called *semidirect products*).

A semidirect sum of Lie algebras  $\mathfrak{g}_1$  and  $\mathfrak{g}_2$  is the direct sum of vector spaces  $\mathfrak{g}_1$  and  $\mathfrak{g}_2$  endowed with the bracket

$$[(\xi_1, \xi_2), (\eta_1, \eta_2)] = ([\xi_1, \eta_1] + \beta(\xi_2)\eta_1 - \beta(\eta_2)\xi_1, [\xi_2, \eta_2]), \quad (21)$$

where  $\beta$  is a Lie algebra homomorphism  $\mathfrak{g}_2 \rightarrow \text{der } \mathfrak{g}_1$ . We will denote the semidirect sum by  $\mathfrak{g}_1 \dot{+} \mathfrak{g}_2$ , or more prudently by  $\mathfrak{g}_1 \dot{+}_\beta \mathfrak{g}_2$ .

**Problem 37.** A semidirect sum of Lie algebras is a Lie algebra.

The elements of the form  $(\xi_1, 0)$  (resp.  $(0, \xi_2)$ ) constitute a subalgebra of  $\mathfrak{g}_1 \dot{+} \mathfrak{g}_2$  isomorphic to  $\mathfrak{g}_1$  (resp.  $\mathfrak{g}_2$ ), usually identified with  $\mathfrak{g}_1$  (resp.  $\mathfrak{g}_2$ ). The subalgebra  $\mathfrak{g}_1$  is an ideal and

$$[\xi_2, \xi_1] = \beta(\xi_2)\xi_1, \quad (\xi_1 \in \mathfrak{g}_1, \xi_2 \in \mathfrak{g}_2). \quad (22)$$

The subalgebra  $\mathfrak{g}_2$  is an ideal if and only if  $\beta = 0$ . In this case the semidirect sum is isomorphic to the direct sum  $\mathfrak{g}_1 \oplus \mathfrak{g}_2$ .

*Example.* Let  $V$  be a vector space considered as a commutative Lie algebra. Then  $\text{der } V = \text{gl}(V)$ . For any linear representation  $\rho: \mathfrak{g} \rightarrow \text{gl}(V)$  of  $\mathfrak{g}$  we may construct the semidirect sum  $V \dot{+}_\rho \mathfrak{g}$  which is also a Lie algebra. The space  $V$  is a commutative ideal in it.

One says that a Lie algebra  $\mathfrak{g}$  splits into a *semidirect sum of Lie subalgebras*  $\mathfrak{g}_1$  and  $\mathfrak{g}_2$  if

- 1)  $\mathfrak{g}_1$  is an ideal;
- 2)  $\mathfrak{g}$  is the direct sum of subspaces  $\mathfrak{g}_1$  and  $\mathfrak{g}_2$  as a vector space.

In this case we have an isomorphism

$$\mathfrak{g}_1 \dot{+}_\beta \mathfrak{g}_2 \cong \mathfrak{g}, \quad (\xi_1, \xi_2) \mapsto \xi_1 + \xi_2,$$

where  $\beta: \mathfrak{g}_2 \rightarrow \text{der } \mathfrak{g}_1$  is the homomorphism defined by formula (22). In this situation we will write  $\mathfrak{g} = \mathfrak{g}_1 \dot{+} \mathfrak{g}_2$  or  $\mathfrak{g} = \mathfrak{g}_2 \dot{+} \mathfrak{g}_1$ .

**Theorem 9.** The tangent algebra of the semidirect product  $G_1 \rtimes_b G_2$  of Lie groups  $G_1$  and  $G_2$  is the semidirect sum  $\mathfrak{g}_1 \dot{+}_\beta \mathfrak{g}_2$  of their tangent algebras and  $\beta = dB$ , where  $B: G_2 \rightarrow \text{Aut } \mathfrak{g}_1$  is a Lie group homomorphism defined by the formula  $B(g_2) = d(b(g_2))$  for any  $g_2 \in G_2$ .

**Problem 38.** Prove this theorem.

*Examples.* 1) Let  $R: G \rightarrow \text{GL}(V)$  be a linear representation of a Lie group  $G$ . The tangent algebra of the semidirect product  $V \rtimes_R G$  (see Example 1.11.1) is the semidirect sum  $V \dot{+}_\rho \mathfrak{g}$ , where  $\rho = dR$ .

2) The Lie group  $GA(V)$  of affine transformations of a vector space  $V$  is identified with the semidirect product  $V \rtimes_{\text{id}} \text{GL}(V)$  (see Example 1.11.2). Its tangent algebra is identified with the semidirect sum  $V \dot{+}_{\text{id}} \text{gl}(V)$ , where  $\text{id}$  is the identity linear representation of the Lie algebra  $\text{gl}(V)$  in  $V$ .

**Problem 39.** Let  $G_1$  and  $G_2$  be simply connected Lie groups. For any homomorphism  $\beta: \mathfrak{g}_2 \rightarrow \text{der } \mathfrak{g}_1$  there exists a homomorphism  $b: G_2 \rightarrow \text{Aut } G_1$ , such that

the  $G_2$ -action on  $G_1$  defined by  $b$  is differentiable and the tangent algebra of the semidirect product  $G_1 \rtimes_b G_2$  is  $\mathfrak{g}_1 \rtimes_{\beta} \mathfrak{g}_2$ .

### Exercises

- 1) The tangent algebra of the group of invertible triangular matrices is the Lie algebra of all triangular matrices.
- 2) Let  $A$  be a finite-dimensional associative algebra with unit 1 over a field  $K$ . Then the multiplicative group  $A^*$  of invertible elements of  $A$  endowed with the induced differentiable structure (as an open subset of the space  $A$ ) is a Lie group. Prove that under the canonical identification of the tangent space  $T_1(A^*)$  with the space  $A$  the bracket in the tangent algebra of the group  $A^*$  is defined by the formula  $[\xi, \eta] = \xi\eta - \eta\xi$ .
- 3) With the notation of 1°, define a bilinear operation  $*$  in the space  $T_e(G)$  by the formula

$$\overline{\xi * \eta} = \alpha(\overline{\xi}, \overline{\eta}) + \alpha(\overline{\eta}, \overline{\xi}).$$

Prove that for a suitable coordinate system this operation coincides with any given commutative bilinear operation in  $T_e(G)$ .

- 4) The tangent algebra of the centralizer  $Z(g)$  of an element  $g \in G$  (see Exercise 1.6)) coincides with

$$\mathfrak{z}(g) = \{\xi \in \mathfrak{g} : (\text{Ad } g)\xi = \xi\} = \{\xi \in \mathfrak{g} : g\xi = \xi g\}.$$

- 5) Suppose  $\xi$  is an element of the tangent algebra  $\mathfrak{g}$  of a Lie group  $G$ . Its centralizer  $Z(\xi)$  in  $G$  defined as

$$Z(\xi) = \{g \in G : (\text{Ad } g)\xi = \xi\}$$

is a Lie subgroup whose tangent algebra coincides with the subalgebra  $\mathfrak{z}(\xi) = \{\eta \in \mathfrak{g} : [\xi, \eta] = 0\}$  called the *centralizer* of  $\xi$  in the Lie algebra  $\mathfrak{g}$ .

- 6) Let  $H$  be a connected Lie subgroup of  $G$ . Its normalizer

$$N(H) = \{g \in G : gHg^{-1} = H\}$$

is a Lie subgroup and the tangent algebra of  $N(H)$  coincides with the algebra

$$\mathfrak{n}(\mathfrak{h}) = \{\xi \in \mathfrak{g} : [\xi, \mathfrak{h}] \subset \mathfrak{h}\},$$

called the *normalizer* of  $\mathfrak{h}$  in  $\mathfrak{g}$ .

- 7) The tangent algebra of  $U_n$  consists of all skewhermitian  $n \times n$  matrices.
- 8) Deduce the Jacobi identity in the tangent algebra of a Lie group directly from the associativity of the product in the Lie group. (Consider the terms of degree  $\leq 3$  in the Taylor series expansions of coordinates of products of any three elements close to the unit.)

- 9) For  $GL_n(\mathbb{C})$  the exponential map is onto, but it is neither open nor injective.
- 10) For  $SL_2(\mathbb{R})$  the exponential map is not onto.
- 11) If the tangent algebra of a connected Lie group  $G$  is commutative then  $G$ , is commutative.
- 12) Any noncompact connected one-dimensional complex Lie group is isomorphic to either  $\mathbb{C}$  or  $\mathbb{C}^*$ .
- 13) Any compact connected one-dimensional complex Lie group is isomorphic to a Lie group of the form  $A(u) = \mathbb{C}/(\mathbb{Z} + \mathbb{Z}u)$ , where  $u \in \mathbb{C}$ ,  $\text{Im } u > 0$ . The Lie groups  $A(u)$  and  $A(v)$  are isomorphic (as complex Lie groups!) if and only if  $v = \frac{au + b}{cu + d}$ , where  $\begin{pmatrix} a & b \\ c & d \end{pmatrix} \in SL_2(\mathbb{Z})$ .
- 14) Any connected compact complex Lie group  $G$  is commutative. (Hint: For any  $\xi \in \mathfrak{g}$  the linear transformation  $\text{ad } \xi$  is diagonalizable and its eigenvalues are purely imaginary.)
- 15) If the center  $Z$  of a connected Lie group  $G$  is discrete then the center of the quotient group  $G/Z$  is trivial.
- 16) A connected Lie group is nilpotent (as an abstract group) if and only if its tangent algebra is nilpotent. (A Lie algebra  $\mathfrak{g}$  is called *nilpotent* if there exists a sequence of subalgebras

$$\mathfrak{g} = \mathfrak{g}_0 \supset \mathfrak{g}_1 \supset \cdots \supset \mathfrak{g}_{m-1} \supset \mathfrak{g}_m = 0,$$

such that  $[\mathfrak{g}, \mathfrak{g}_i] \subset \mathfrak{g}_{i+1}$ .) (Hint: Prove that the center of a connected nilpotent Lie group is of positive dimension.)

- 17) The connected components of open sets in the induced topology on a virtual Lie subgroup constitute a base of its inner topology.
- 18) Let  $\mathfrak{g}$  be the *Heisenberg algebra* i.e. the Lie algebra with basis  $\{x_1, \dots, x_n, y_1, \dots, y_n, z\}$  such that  $[x_i, y_i] = z$  ( $i = 1, \dots, n$ ), all the other brackets of base elements being zero. Find  $\text{Aut } \mathfrak{g}$ ,  $\text{Int } \mathfrak{g}$  and  $\text{Aut } \mathfrak{g}/\text{Int } \mathfrak{g}$ .
- 19) Let  $\mathfrak{g}$  be the Lie algebra of diagonal complex  $3 \times 3$  matrices whose diagonal elements  $x_1, x_2, x_3$  satisfy the condition  $x_1 : x_2 : x_3 = c_1 : c_2 : c_3$ , where  $c_1, c_2, c_3$  are fixed real numbers. The group  $\text{Int } \mathfrak{g}$  is a Lie subgroup of  $\text{Aut } \mathfrak{g}$  if and only if the differences  $c_1 - c_2$  and  $c_2 - c_3$  are commensurable.
- 20) Let a Lie group  $G$  split (as an abstract group) into a semidirect product of its virtual Lie subgroups  $G_1$  and  $G_2$ . Then  $G_1$  and  $G_2$  are genuine Lie subgroup.

### Hints to Problems

2. In  $V$ , choose a basis and assign to any linear transformation  $X \in GL(V)$  the matrix  $\bar{X} = [X] - E$ , where  $[X]$  is the matrix of  $X$  in this basis. The elements of  $\bar{X}$  may be taken for local coordinates in a neighbourhood of the unit  $E$ ; then  $E$  has zero coordinates. A straightforward verification shows that

$$\overline{XY} = \bar{X} + \bar{Y} + \bar{X}\bar{Y}.$$

Hence,  $\alpha(X, Y) = XY$  and  $\gamma(X, Y) = XY - YX$  for any  $X, Y$ . In the associated coordinate system of the tangent space  $L(V)$  of the Lie group  $GL(V)$  (at  $E$ ) the coordinates of a linear transformation coincide with the elements of its matrix. Therefore

$$[X, Y] = XY - YX \quad \text{for any } X, Y \in L(V).$$

3. Choose coordinate systems in neighbourhoods of the units of  $G$  and  $H$ . Let  $\gamma_G$  and  $\gamma_H$  be bilinear vector-functions defined by formula (3) in these coordinate systems on  $G$  and  $H$ , respectively. Let  $C$  be the Jacobi matrix of the map  $f$  at  $e \in G$ . Then

$$\overline{f(x)} = C\bar{x} + \dots,$$

where dots stand for the terms of degree  $\geq 2$ . Hence

$$\overline{f((x, y))} = C\gamma_G(\bar{x}, \bar{y}) + \dots,$$

$$\overline{(f(x), f(y))} = \gamma_H(C\bar{x}, C\bar{y}) + \dots,$$

where dots stand for the terms of degree  $\geq 3$ . Since  $f((x, y)) = (f(x), f(y))$ , we have

$$C\gamma_G(\bar{x}, \bar{y}) = \gamma_H(C\bar{x}, C\bar{y}).$$

Furthermore

$$\overline{df(\xi)} = C\xi.$$

Therefore, the above formula and the definition of the brackets in  $\mathfrak{g}$  and  $\mathfrak{h}$  imply that

$$df([\xi, \eta]) = [df(\xi), df(\eta)] \quad \text{for any } \xi, \eta \in \mathfrak{g},$$

i.e.  $df$  is a tangent algebra homomorphism.

4. Apply Problem 3 to the identity embedding of the subgroup.
5. Find the coefficient of  $t$  in the polynomial  $\det(E + tX)$ .
6. Apply Problem 3 to the canonical homomorphism  $p: G \rightarrow H$ .
7. In the definitions of the representations  $\text{Ad}$  and  $\text{Sq}$  put  $A = E + tY$  and differentiate with respect to  $t$  at  $t = 0$ .
10. It suffices to prove these formulas for simple tensors  $f$  and  $F$ , respectively. It can be done using Problems 8 and 9. The other possible approach is to take a derivative of formulas (1.1) and (1.2) with respect to  $A$  (at  $E$ ).
11. Use the fact that  $a$  is a  $G$ -action, i.e.  $a(g_1g_2) = a(g_1)a(g_2)$ .
12. The simplest approach is to start from the relation  $(gxg^{-1})g = gx$ .

13. II  
a  
ti  
to  
15. T  
fr  
w  
17. B  
tl  
a  
18. S  
tl  
19. A  
g  
20. A  
G  
21. T  
ir  
tl  
ta  
22. II  
  
C  
s  
h  
23. M  
24. T  
o  
P  
F  
25. F  
26. U  
27. F  
  
28. F  
29. F  
30. S  
v  
a

13. If we consider  $\text{Ad}$  as a Lie group homomorphism  $G \rightarrow \text{Aut } \mathfrak{g}$ , then  $\text{ad}$  is a Lie algebra homomorphism  $\mathfrak{g} \rightarrow \text{Der } \mathfrak{g}$  (see Example 3.2). Hence  $\text{ad } \xi$  is a derivation of the Lie algebra  $\mathfrak{g}$  for any  $\xi \in \mathfrak{g}$ . By anticommutativity this is equivalent to the Jacobi identity.
15. The Taylor series expansion of the coordinates of  $g\xi$  (resp.  $\xi g$ ) is obtained from the Taylor series expansion of the coordinates of the group products, when we choose only terms linear in the second (resp. first) factor.
17. By the definition,  $\text{Ad } g$  is the differential of the inner automorphism  $a(g)$  of the group  $G$ . By Theorem 4  $\text{Ad } g = E$  if and only if  $a(g)$  is the identity automorphism, i.e. when  $g \in Z(G)$ .
18. Since  $Z(G)$  is the kernel of  $\text{Ad}$ , the tangent algebra of  $Z(G)$  is the kernel of the tangent representation  $\text{ad}$  (see 2°), and the latter is just  $\mathfrak{z}(\mathfrak{g})$ .
19. Apply Theorem 5 to the homomorphism  $T: G \rightarrow \text{GL}(V)$  and the Lie subgroup  $\text{GL}(V; U) \subset \text{GL}(V)$ . (See the solution of Problem 1.24).
20. Apply Theorem 5 to the identity embedding  $G_1 \hookrightarrow G$  and the subgroup  $G_2 \subset G$ .
21. The subgroup  $H$  is normal if and only if it is invariant with respect to the inner automorphisms of the group  $G$ . By Problem 20 this is equivalent to the invariance of the tangent algebra  $\mathfrak{h}$  with respect to the adjoint representation of  $G$ . Next, apply Problem 25 and Theorem 2.
22. If  $g(t)$  is a one-parameter subgroup, then

$$\frac{dg(t)}{dt} = \left. \frac{dg(s+t)}{ds} \right|_{s=0} = \left. \frac{dg(s)}{ds} \right|_{s=0} \cdot g(t).$$

Conversely, if the path  $g(t)$  satisfies (15), where  $\xi(t) = \text{const}$ , then for any fixed  $s \in \mathbb{R}$  the path  $h(t) = g(t+s)$  satisfies the same equation with the initial value  $h(0) = g(s)$ . If, moreover,  $g(0) = e$ , then  $h(t) = g(t)g(s)$ .

23. Make a linear change of the variable  $t$  in equation (15).
24. The differentiability in a neighbourhood of zero follows from the theorem on smooth dependence of solution of a system of differential equations on parameters. The global differentiability can be proved using the fact that by Problem 23  $\exp \xi = (\exp \xi/m)^m$  for any  $m \in \mathbb{Z}$ .
25. Problem 23 and the definition of  $g_\xi(t)$  imply that  $(d_0 \exp)(\xi) = \xi$ .
26. Use Problem 16.
27. Prove that  $(\text{Ad } \exp t\xi)\eta = \eta$ , next prove that

$$\frac{d}{dt}(\exp t\xi \cdot \exp t\eta) = (\xi + \eta)\exp t\xi \cdot \exp t\eta.$$

28. Follows from Problem 20.
29. Follows from Problem 26.
30. Show by induction in  $n$  that  $\Gamma$  is generated by a linear independent set of vectors. For this choose an indivisible vector  $e_1 \in \Gamma$  and prove that  $\Gamma/\mathbb{Z}e_1$  is a discrete subgroup of the  $(n-1)$ -dimensional vector group  $\mathbb{R}^n/\mathbb{R}e_1$ .

31. Make use of the fact that

$$\delta(\exp \xi) = \exp d\delta(\xi) \quad \text{for any } \xi \in \mathfrak{g}.$$

32. Make use of Proposition 1.16.
33. The neighbourhood  $\mathcal{O}_H(e)$  and the submanifold  $S \subset G$  are constructed as in the solution of Problem 1.19. The countability of  $T$  follows from the fact that  $H$  can only contain a finite or countable family of mutually nonintersecting open subsets. To prove the latter statement one should make use of the fact that any countable subset of  $\mathbb{R}^n$  is discrete.
34. In order to prove the first statement of the theorem it is necessary to show that the identity embedding of  $G_1$  into  $G_2$  is differentiable. With the help of Problem 33 applied to  $G_2$  one can show that a sufficiently small connected neighbourhood of the unit of  $G_1$  is contained in a neighbourhood of the unit of  $G_2$  which is a submanifold of  $G$ . This implies the required differentiability. The second part of the theorem is proved as Theorem 5.
35. The differentiability of the  $(\text{Aut } \mathfrak{g})$ -action on  $\mathfrak{g}$  and the fact that automorphisms commute with the exponential map imply the differentiability of the map

$$(\text{Aut } G) \times G \rightarrow G, \quad (\alpha, g) \mapsto \alpha(g) \quad (23)$$

on  $(\text{Aut } G) \times \mathcal{O}(e)$ , where  $\mathcal{O}(e)$  is a neighbourhood of the unit of  $G$ . On the other hand, the theorem on differentiable dependence of a solution of a system of differential equations on parameters implies that  $\alpha(g)$  is differentiable with respect to  $\alpha$  for any  $g$ . The differentiability of the map (23) at any point  $(\alpha_0, g_0)$  follows from this with the help of the identity

$$\alpha(g) = \alpha(g_0)\alpha(g_0^{-1}g).$$

38. Calculate the differential of the adjoint representation of  $G_1 \times_{\beta} G_2$ .
39. The desired homomorphism  $b$  is obtained from  $\beta$  by "integrating", i.e. the procedure inverse to the one described in the formulation of Theorem 9. The differentiability of the  $G_2$ -action on  $G_1$  defined by it follows from Problem 35.

### § 3. Connectedness and Simple Connectedness

As shown in § 2 (Theorems 2.4 and 2.6) connectedness and simple connectedness play an important role even at the first stages of the Lie group theory. That is why we have devoted to them a separate section.

The definition of the fundamental group and the proof of topological theorems used in this section (the existence of the simply connected covering, the exactness of the homotopy sequence of a locally trivial bundle, etc.) can be found e.g. in

[56]  
for r  
man

1°  
of tv  
two  
these  
man  
diffe  
of a  
num

D  
TL  
G ar

Pr  
Pr

Pr  
neig

Pr  
TL

diffe  
1)

2)  
3)

Pr  
TL

grou  
Pr

Pr  
is th

A  
tran

mat:  
This

Pr

C  
mat:

linea

[56]. One should have in mind that these theorems hold and are naturally proved for more general topological spaces and their maps rather than differentiable manifolds and differentiable maps we deal with in this book.

**1°. Connectedness.** A topological space is called *connected* if it is not a union of two non-intersecting non-empty open subsets and *pathwise connected* if any two of its points can be joined by a continuous path. For a differentiable manifold these notions coincide. Moreover, any two points of a connected differentiable manifold can be joined by a *differentiable* path. Connected components of a differentiable manifold are both open and closed. The assumption of existence of a countable base implies that a differentiable manifold has a finite or countable number of connected components.

Denote by  $G^0$  the connected component of a Lie group  $G$ , which contain  $e$ .

**Theorem 1.**  $G^0$  is a normal Lie subgroup of  $G$ . Other connected components of  $G$  are cosets with respect to  $G^0$ . The quotient group  $G/G^0$  is discrete.

**Problem 1.** Prove Theorem 1.

**Problem 2.** Any open Lie subgroup of  $G$  is closed and contains  $G^0$ .

**Problem 3.** A connected Lie group is generated (as an abstract group) by any neighbourhood of the unit.

**Problem 4.** Any closed subgroup of a finite index of a Lie group is open.

**Theorem 2.** Let  $G$  be a Lie group and  $\alpha$  its transitive action on a connected differentiable manifold  $X$ . Then

- 1) the Lie group  $G^0$  also acts transitively on  $X$ ;
- 2)  $G/G^0 \cong G_x/G_x \cap G^0$  for any point  $x \in X$ ;
- 3) if the stabilizer  $G_x$  is connected for some  $x \in X$  then so is  $G$ .

**Problem 5.** Prove Theorem 2.

Theorem 2 enables us to answer the question whether the classical linear Lie groups are connected.

**Problem 6.**  $SL_n(K)$  is connected.

**Problem 7.**  $O_n(K)$  has two connected components. One that contains the unit is the subgroup  $SO_n(K)$  of unimodular orthogonal matrices.

An  $n \times n$  matrix ( $n$  being even) is called *symplectic* if the corresponding linear transformation of  $K^n$  preserves the skew-symmetric bilinear form with the matrix  $\begin{pmatrix} 0 & E \\ -E & 0 \end{pmatrix}$ . The group of symplectic matrices is denoted by  $Sp_n(K)$ . This is a Lie group of dimension  $n(n+1)/2$  (see 1.5°, Example 2).

**Problem 8.**  $Sp_n(K)$  is connected.

Consider a more complicated example. Let  $k, l > 0$  and  $k + l = n$ . A real matrix of order  $n$  is called *pseudoorthogonal of signature  $(k, l)$*  if the corresponding linear transformation preserves the quadratic form

$$q(x) = x_1^2 + \cdots + x_k^2 - x_{k+1}^2 - \cdots - x_n^2.$$

The group of pseudoorthogonal matrices of signature  $(k, l)$  is denoted by  $O_{k,l}$ . It is a Lie group of dimension  $n(n-1)/2$  (see Example 1.5.1). Clearly  $O_{k,l} \cong O_{l,k}$ . As in the case of usual orthogonal matrices, the subgroup  $SO_{k,l}$  of unimodular pseudoorthogonal matrices is an open subgroup of index 2 in  $O_{k,l}$ . But, as we will see, it is not connected.

**Problem 9.** The upper left minor  $d_k(A)$  of order  $k$  of any pseudoorthogonal matrix  $A \in O_{k,l}$  is nonzero.

$SO_{k,l}$  contains matrices with both positive and negative values of  $d_k$ . Such matrices are easy to find even among diagonal matrices. Since the subsets that are distinguished by inequalities  $d_k > 0$  and  $d_k < 0$  are open, the group  $SO_{k,l}$  is not connected.

**Problem 10.**  $SO_{k,l}$  has two connected components. The connected component containing the unit is distinguished by  $d_k > 0$ .

**2°. Covering Homomorphisms.** The principal technique of Lie group theory consists in replacing the study of Lie groups by the study of their tangent algebras. The applicability of this method depends on the extent to which a Lie group can be recovered from its tangent algebra. Such a recovery is possible and unique for simply connected Lie groups (Corollary of Theorem 2.6), and connected Lie groups are determined up to covering homomorphisms.

Recall that a *covering* is a locally trivial bundle with a discrete fibre.

**Problem 11.** Let  $f$  be a homomorphism of a connected Lie group  $G$  into a Lie group  $H$ . The following conditions are equivalent:

- 1)  $f$  is a diffeomorphism of a neighbourhood of the unit of  $G$  onto a neighbourhood of the unit of  $H$ ;
- 2) the kernel of  $f$  is discrete;
- 3)  $f$  is a covering;
- 4)  $df$  is a tangent algebra isomorphism.

Homomorphisms satisfying conditions of Problem 11 will be called *covering homomorphisms*.

*Examples.* 1) The homomorphism

$$f: \mathbb{R} \rightarrow \mathbb{T}, \quad \text{where } f: x \mapsto e^{ix},$$

is covering since its kernel, i.e.  $2\pi\mathbb{Z}$ , is discrete.

2) Consider the adjoint representation  $\text{Ad}$  of the Lie group  $\text{SL}_2(\mathbb{C})$ . The transformations

$$\text{Ad } A: X \mapsto AXA^{-1} \quad (A \in \text{SL}_2(\mathbb{C}), X \in \mathfrak{sl}_2(\mathbb{C}))$$

preserve the function  $\det$  which is a nondegenerate quadratic form on  $\mathfrak{sl}_2(\mathbb{C})$  and

Ad Sl  
which  
Sir  
cides  
SO(s  
SO<sub>3</sub>(

Pr  
cont

Th  
morp  
of G.

3°.  
fold  
one.

by a  
conn

Th

(F

p:  $\tilde{X}$

$\tilde{x}_0 \in$

map

com

Le

cove

of th

a un

TI

isom

Ther

the

with

TI

wher

The

( $\tilde{G}_1$ ,

$\tilde{G}_1 -$

$\text{Ad } \text{SL}_2(\mathbb{C}) \subset \text{O}(\mathfrak{sl}_2(\mathbb{C}), \det) \simeq \text{O}_3(\mathbb{C})$ . The kernel of  $\text{Ad}$  is the center of  $\text{SL}_2(\mathbb{C})$  which consists of  $E$  and  $-E$ .

Since  $\dim \text{SL}_2(\mathbb{C}) = \dim \text{O}_3(\mathbb{C}) = 3$  and  $\text{SL}_2(\mathbb{C})$  is connected,  $\text{Ad } \text{SL}_2(\mathbb{C})$  coincides with the connected component of  $\text{O}(\mathfrak{sl}_2(\mathbb{C}), \det)$ , i.e. with the subgroup  $\text{SO}(\mathfrak{sl}_2(\mathbb{C}), \det) \cong \text{SO}_3(\mathbb{C})$ . Thus, there is a covering homomorphism  $\text{SL}_2(\mathbb{C}) \rightarrow \text{SO}_3(\mathbb{C})$  whose kernel consists of  $E$  and  $-E$ .

**Problem 12.** Any discrete normal subgroup of a connected Lie group  $G$  is contained in the center of  $G$ .

Thus, for a given connected Lie group  $G$  the description of covering homomorphisms  $G \rightarrow H$  boils down to the description of discrete central subgroups of  $G$ .

**3°. Simply Connected Covering Lie Groups.** A connected differentiable manifold is called *simply connected* if any closed path in it is homotopic to a trivial one. It is known [45] that any connected differentiable manifold can be covered by a simply connected manifold. For the sake of brevity we call it the simply connected covering.

The following functorial property holds.

(F) Let  $X$  and  $Y$  be connected manifolds,  $f: X \rightarrow Y$  a differentiable map. Let  $p: \tilde{X} \rightarrow X$  and  $q: \tilde{Y} \rightarrow Y$  be the simply connected coverings. Then for any points  $\tilde{x}_0 \in \tilde{X}$  and  $\tilde{y}_0 \in \tilde{Y}$  such that  $f(p(\tilde{x}_0)) = q(\tilde{y}_0)$  there exists a unique differentiable map  $\tilde{f}: \tilde{X} \rightarrow \tilde{Y}$  such that the diagram

$$\begin{array}{ccc}
 \tilde{X} & \xrightarrow{\tilde{f}} & \tilde{Y} \\
 \downarrow p & & \downarrow q \\
 X & \xrightarrow{f} & Y
 \end{array} \tag{F}$$

commutes and  $\tilde{f}(\tilde{x}_0) = \tilde{y}_0$ . In this case we say that  $\tilde{f}$  covers  $f$ .

Let  $p: \tilde{X} \rightarrow X$  be the simply connected covering. The diffeomorphisms of  $\tilde{X}$  covering the identity diffeomorphism of  $X$  form the group  $\Gamma(p)$  called the *group of the covering*  $p$ . By (F), for any  $\tilde{x}_1, \tilde{x}_2 \in \tilde{X}$  such that  $p(\tilde{x}_1) = p(\tilde{x}_2)$  there exists a unique element of  $\Gamma(p)$  which transforms  $\tilde{x}_1$  into  $\tilde{x}_2$ .

The group  $\Gamma(p)$  is isomorphic to the fundamental group  $\pi_1(X)$  of  $X$ ; the isomorphism is obtained as follows. Choose a point  $\tilde{x}_0$  in  $\tilde{X}$  and let  $x_0 = p(\tilde{x}_0)$ . Then to any element  $\gamma$  of  $\Gamma(p)$  we assign the class of closed paths in  $X$  with the origin in  $x_0$  which are images under  $p$  of those paths in  $\tilde{X}$  which join  $\tilde{x}_0$  with  $\gamma(\tilde{x}_0)$ .

**Theorem 3.** Any connected Lie group  $G$  is isomorphic to the quotient group  $\tilde{G}/N$ , where  $\tilde{G}$  is a simply connected Lie group, and  $N$  is its discrete central subgroup. The pair  $(\tilde{G}, N)$  is defined by these conditions uniquely up to an isomorphism, i.e. if  $(\tilde{G}_1, N_1)$  and  $(\tilde{G}_2, N_2)$  are two such pairs, then there is a Lie group isomorphism  $\tilde{G}_1 \rightarrow \tilde{G}_2$  that transforms  $N_1$  into  $N_2$ .

The canonical homomorphism  $\tilde{G} \rightarrow \tilde{G}/N$  is covering and therefore the group  $\tilde{G}$  is called the *simply connected covering Lie group* of  $G$ .

*Proof.* Let  $p: \tilde{G} \rightarrow G$  be a simply connected covering of the group manifold  $G$  and  $\tilde{e} \in \tilde{G}$  a pullback of the unit  $e$  of  $G$ . The mapping  $p \times p: \tilde{G} \times \tilde{G} \rightarrow G \times G$  is the simply connected covering of the manifold  $G \times G$ . Define the multiplication  $\tilde{\mu}: \tilde{G} \times \tilde{G} \rightarrow \tilde{G}$  to be the covering map for the multiplication  $\mu$  in  $G$  which transforms  $(\tilde{e}, \tilde{e})$  into  $\tilde{e}$ . Define the inversion  $\tilde{\iota}: \tilde{G} \rightarrow \tilde{G}$  to be the covering map of the inversion  $\iota$  in  $G$  which transforms  $\tilde{e}$  into itself.

**Problem 13.** The multiplication  $\tilde{\mu}$  and the inversion  $\tilde{\iota}$  satisfy group axioms for  $\tilde{G}$  with  $\tilde{e}$  as the unit.

Thus, we have turned the manifold  $\tilde{G}$  into a Lie group. The definition of multiplication in  $\tilde{G}$  implies that  $p$  is a homomorphism. Its kernel  $N$  is a discrete central subgroup (Problems 11 and 12) and  $G \cong \tilde{G}/N$  (Theorem 1.5).

Now, let  $\tilde{G}_1$  and  $\tilde{G}_2$  be simply connected Lie groups,  $N_1$  and  $N_2$  their discrete central subgroups and  $f: \tilde{G}_1/N_1 \rightarrow \tilde{G}_2/N_2$  a Lie group isomorphism. The canonical homomorphisms  $p_1: \tilde{G}_1 \rightarrow \tilde{G}_1/N_1$  and  $p_2: \tilde{G}_2 \rightarrow \tilde{G}_2/N_2$  are covering. By (F) there is a diffeomorphism  $\tilde{f}: \tilde{G}_1 \rightarrow \tilde{G}_2$  that covers  $f$  and transforms the unit  $\tilde{e}_1$  of  $G_1$  into the unit  $\tilde{e}_2$  of  $G_2$ . Since the diagram

$$\begin{array}{ccc} \tilde{G}_1 & \xrightarrow{\tilde{f}} & \tilde{G}_2 \\ p_1 \downarrow & & \downarrow p_2 \\ G_1/N_1 & \xrightarrow{f} & G_2/N_2 \end{array}$$

commutes,  $\tilde{f}(N_1) = N_2$ .

**Problem 14.** The map  $\tilde{f}$  is a group isomorphism.

The theorem is proved.  $\square$

**Problem 15.** Under the assumptions of the theorem,  $N \cong \pi_1(G)$ .

In particular, this implies that the fundamental group  $\pi_1(G)$  of any connected Lie group  $G$  is abelian.

Theorem 3 and corollaries of Theorem 1.6 imply that the connected Lie groups whose tangent algebras are isomorphic to a given Lie algebra, if exist, are described as follows: among them there exists a simply connected one, unique up to an isomorphism and the other ones are obtained from it taking quotients modulo different discrete central subgroups. In Chapter VI we will show that for any finite-dimensional Lie algebra  $\mathfrak{g}$  there exists a Lie group whose tangent algebra is isomorphic to  $\mathfrak{g}$ .

Theorem 3 may be viewed as a generalization of the description of connected commutative Lie groups obtained in 2.7.

**4°. Exact Homotopy Sequence.** In order to calculate fundamental groups of Lie groups it is convenient to use a part of the exact homotopy sequence of a locally trivial bundle.

Let  $X$  a bundle with inverse image  $Z$  respectively homomorphisms

are defined path  $\beta$  in  $p(\alpha) = \beta$ .  $\alpha$  depends

is well-defined The part

Here, the 1)  $\text{Ker } j$  2) the  $f$  3)  $\partial$  is  $s$  Also, if  $Y$  is homomorphism Let us a connected distinguished Define  $i$  to

**Problem** Thus, the **Theorem**  $i: H \rightarrow G$

is exact. **Corollary** **Corollary** Now with classical

Let  $X$  and  $Y$  be connected differentiable manifolds,  $p: X \rightarrow Y$  a locally trivial bundle with fibre  $Z$ . Let  $i: Z \rightarrow X$  be a diffeomorphism of  $Z$  with  $p^{-1}(y_0)$ , the inverse image of a distinguished point  $y_0$  of  $Y$ . Fix points  $x_0$  and  $z_0$  in  $X$  and  $Z$  respectively so that  $i(z_0) = x_0$  and therefore  $p(x_0) = y_0$ . Then the canonical homomorphisms

$$p_*: \pi_1(X, x_0) \rightarrow \pi_1(Y, y_0)$$

$$i_*: \pi_1(Z, z_0) \rightarrow \pi_1(X, x_0)$$

are defined. Let  $\pi_0(Z)$  be the set of connected components of  $Z$ . For any closed path  $\beta$  in  $Y$  beginning at  $y_0$  there is a path  $\alpha$  on  $X$  beginning at  $x_0$  such that  $p(\alpha) = \beta$ . A connected component of  $Z$  whose image contains the end of the path  $\alpha$  depends only on the homotopy class of  $\beta$ . Therefore the map

$$\partial: \pi_1(Y, y_0) \rightarrow \pi_0(Z)$$

is well-defined.

The part of the exact homotopy sequence we need is of the form

$$\pi_1(Z) \xrightarrow{i_*} \pi_1(X) \xrightarrow{p_*} \pi_1(Y) \xrightarrow{\partial} \pi_0(Z) \longrightarrow 0$$

Here, the exactness means the following:

- 1)  $\text{Ker } p_* = \text{Im } i_*$ ;
- 2) the fibres of  $\partial$  are the cosets of  $\pi_1(Y)$  with respect to  $\text{Im } p_*$ ;
- 3)  $\partial$  is surjective.

Also, if  $\pi_2(Y) = 0$ , i.e. any continuous map of a two-dimensional sphere into  $Y$  is homotopic to a trivial one, then  $i_*$  is injective.

Let us apply the above to the locally trivial bundle  $p: G \rightarrow G/H$ , where  $G$  is a connected Lie group,  $H$  its Lie subgroup. Take the unit  $e$  of  $G$  to be the distinguished point of  $G$  and let  $p(e) = H$  be the distinguished point of  $G/H$ . Define  $i$  to be the identity embedding of  $H$  into  $G$ .

In this case  $\pi_0(Z)$  is the group  $H/H^0$ . Denote by  $\iota$  the inversion in this group.

**Problem 16.** The map  $\iota \circ \partial: \pi_1(G/H) \rightarrow H/H^0$  is a homomorphism.

Thus, the following theorem holds.

**Theorem 4.** Let  $G$  be a connected Lie group,  $p: G \rightarrow G/H$  the canonical map,  $i: H \rightarrow G$  the identity embedding. Then the sequence of groups and homomorphisms

$$\pi_1(H) \xrightarrow{i_*} \pi_1(G) \xrightarrow{p_*} \pi_1(G/H) \xrightarrow{\iota \circ \partial} H/H^0 \longrightarrow 0$$

is exact. Moreover, if  $\pi_2(G/H) = 0$ , then  $i_*$  is injective.

**Corollary 1.** If  $\pi_1(G/H) = \pi_2(G/H) = 0$ , then  $\pi_1(G) \cong \pi_1(H)$ .

**Corollary 2.** If  $G$  is simply connected, then  $\pi_1(G/H) \cong H/H^0$ .

Now we will apply Corollary 1 in order to calculate the fundamental groups of classical complex Lie groups.

**Problem 17.**  $SL_n(\mathbb{C})$  and  $Sp_{2n}(\mathbb{C})$  are simply connected.

Since  $SO_3(\mathbb{C}) \cong SL_2(\mathbb{C})/\{E, -E\}$  (see Example 2.2) and  $SL_2(\mathbb{C})$  is simply connected, we have  $\pi_1(SO_3(\mathbb{C})) \cong \mathbb{Z}_2$ .

**Problem 18.**  $\pi_1(SO_n(\mathbb{C})) \cong \mathbb{Z}_2$  for  $n \geq 3$ .

### Exercises

- 1) A Lie subgroup  $H$  of a Lie group  $G$  contains  $G^0$  if and only if the manifold  $G/H$  is discrete.
- 2) If in the definition of a Lie group we omit the assumption that the group manifold possesses a countable base then any connected Lie group still possesses a countable base.
- 3)  $GL_n(\mathbb{C})$  is connected and  $GL_n(\mathbb{R})$  has two connected components.
- 4)  $U_n$  and  $SU_n = \{A \in U_n: \det A = 1\}$  are connected.
- 5) The group  $O_{k,l}/O_{k,l}^0$ , where  $k, l > 0$ , is the direct product of two cyclic groups of order 2.
- 6) Construct the covering homomorphism  $SU_2 \rightarrow SO_3$ .
- 7) Suppose  $\alpha$  is an action of a simply connected Lie group  $G$  on a connected differential manifold  $X$  and  $p: \tilde{X} \rightarrow X$  the simply connected covering. Then there exists a  $G$ -action  $\tilde{\alpha}$  on  $\tilde{X}$  such that  $p(\tilde{\alpha}(g)\tilde{x}) = \alpha(g)p(\tilde{x})$ .
- 8)  $SU_n$  and  $Sp_{2n}$  (see exercise 1.3) are simply connected.
- 9)  $\pi_1(SO_n) \cong \mathbb{Z}_2$  for  $n \geq 3$ .
- 10) Any connected two-dimensional real Lie group is either commutative or isomorphic to the group of orientation preserving affine transformations of the line.
- 11) For any connected Lie group  $G$  the differentials of all its automorphisms form a Lie subgroup in  $\text{Aut } \mathfrak{g}$ . (Hint: characterize a sufficiently small neighbourhood of the unit of this subgroup in terms of the  $(\text{Aut } \mathfrak{g})$ -action on the simply connected covering Lie group of  $G$ .)

### Hints to Problems

1. Use the fact that the inversion, left and right translations, and inner automorphisms are diffeomorphisms of the group manifold, and therefore can only permute connected components.
2. An open subgroup is closed since its complement is the union of cosets and each coset is also an open subset.
3. Prove that the subgroup generated by a neighbourhood of the unit is open and use Problem 2.
5. Let  $x \in X$ . Theorem 1.1 yields  $\text{rk } \alpha_x = \dim X$ . Applying this theorem to the restriction of the action  $\alpha$  to  $G^0$  we find that the orbit  $\alpha(G^0)x$  contains a neighbourhood of  $x$ . Hence, all the orbit of  $G^0$  are open in  $X$ . Since  $X$  is connected, there is actually only one orbit, i.e.  $G^0$  acts transitively on  $X$ . Hence, in any connected component of  $G$ , there is an element of the subgroup  $G_x$  (for any given point  $x \in X$ ). The other statements of the theorem are deduced from here.

6. Cons that  $SL_n$
7. Clear to sh  $SO_n$  of an
8. Cons that t to Sp
9. If  $d_k$  has a vecto the fc
10. For  $k$

- Prov. morph numl conn
11. The  $\epsilon$  2)  $\Rightarrow$
  12. Let  $\Lambda$   $n \in \Lambda$

- Its ir belor
13. Since

wher

is cov

and t

6. Consider the natural  $SL_n(K)$ -action on the punctured space  $K^n \setminus \{0\}$ . Prove that the stabilizer of any point is diffeomorphic to the direct product  $SL_{n-1}(K) \times K^{n-1}$ .
7. Clearly,  $SO_n(K)$  is an open subgroup of index 2 in  $O_n(K)$ . Therefore, it suffices to show that  $SO_n(K)$  is connected. In order to do this consider the natural  $SO_n(K)$ -action on the sphere  $x_1^2 + \cdots + x_n^2 = 1$  and prove that the stabilizer of any point is isomorphic to  $SO_{n-1}(K)$ .
8. Consider the natural  $Sp_{2n}(K)$ -action on the punctured space  $K^{2n} \setminus \{0\}$ . Prove that this action is transitive and the stabilizer of any point is diffeomorphic to  $Sp_{n-2}(K) \times K^{2n-1}$ .
9. If  $d_k(A) = 0$  then the image of the subspace spanned by the first  $k$  basic vectors has a nonzero intersection with the subspace spanned by the last  $l$  basic vectors. This is impossible, since the quadratic form  $q$  is positive definite on the former and negative definite on the latter.
10. For  $k \geq 2$  and  $l \geq 1$  consider the  $SO_{k,l}$ -action on the hyperboloid

$$x_1^2 + \cdots + x_k^2 - x_{k+1}^2 - \cdots - x_n^2 = 1.$$

Prove that this action is transitive and the stabilizer of any point is isomorphic to  $SO_{k-1,l}$ . Use the isomorphism  $SO_{k,l} \cong SO_{l,k}$  to prove that the number of connected components of  $SO_{k,l}$  does not exceed the number of connected components of  $SO_{1,1}$  which equals 2.

11. The equivalences 1)  $\Leftrightarrow$  2)  $\Leftrightarrow$  4) follow from Theorem 1.2 and the implication 2)  $\Rightarrow$  3) follows from Theorems 1.3 and 1.5.
12. Let  $N$  be a discrete normal subgroup of a connected Lie group  $G$ . For any  $n \in N$  consider the map

$$G \rightarrow N, \quad \text{where } g \mapsto gng^{-1}.$$

Its image is connected, hence consists of one point  $n$ . That means that  $n$  belongs to the center of  $G$ .

13. Since each of the maps

$$\tilde{\mu} \circ (\tilde{\mu} \times id), \tilde{\mu} \circ (id \times \tilde{\mu}): \tilde{G} \times \tilde{G} \times \tilde{G} \rightarrow \tilde{G},$$

where

$$\tilde{\mu} \circ (\tilde{\mu} \times id): (\tilde{x}, \tilde{y}, \tilde{z}) \mapsto \tilde{\mu}(\tilde{\mu}(\tilde{x}, \tilde{y}), \tilde{z}),$$

$$\tilde{\mu} \circ (id \times \tilde{\mu}): (\tilde{x}, \tilde{y}, \tilde{z}) \mapsto \tilde{\mu}(\tilde{x}, \tilde{\mu}(\tilde{y}, \tilde{z})),$$

is covering for the map

$$G \times G \times G \rightarrow G, \quad (x, y, z) \mapsto xyz,$$

and transforms  $(\tilde{e}, \tilde{e}, \tilde{e})$  into  $\tilde{e}$  we obtain the associativity of the multiplication

$\tilde{\mu}$ . We similarly prove that

$$\tilde{\mu}(\tilde{x}, \tilde{\iota}(\tilde{x})) = \tilde{\mu}(\tilde{\iota}(\tilde{x}), \tilde{x}) = \tilde{e}$$

and

$$\tilde{\mu}(\tilde{x}, \tilde{e}) = \tilde{\mu}(\tilde{e}, \tilde{x}) = \tilde{x}.$$

14. Each of the maps

$$\tilde{G}_1 \times \tilde{G}_1 \rightarrow \tilde{G}_2, \quad (\tilde{x}, \tilde{y}) \mapsto \tilde{f}(\tilde{x}\tilde{y}), \quad (\tilde{x}, \tilde{y}) \mapsto \tilde{f}(\tilde{x})\tilde{f}(\tilde{y}),$$

covers the map

$$(\tilde{G}_1/N_1) \times (\tilde{G}_1/N_1) \rightarrow \tilde{G}_2/N_2, \quad (x, y) \mapsto f(xy),$$

and transforms  $(\tilde{e}_1, \tilde{e}_1)$  into  $\tilde{e}_2$ . Hence,  $\tilde{f}(\tilde{x}\tilde{y}) = \tilde{f}(\tilde{x})\tilde{f}(\tilde{y})$ .

15. Let  $p: \tilde{G} \rightarrow G$  be a covering homomorphism with kernel  $N$ . Prove that the elements of the group  $\Gamma(p)$  are multiplications by elements of  $N$ .
16. Let  $\beta_1$  and  $\beta_2$  be closed paths on  $G/H$  with the source at  $p(e)$ . Let  $\alpha_1$  and  $\alpha_2$  be paths on  $G$  beginning at  $e$  such that  $p(\alpha_1) = \beta_1$  and  $p(\alpha_2) = \beta_2$ . Let the ends of  $\alpha_1$  and  $\alpha_2$  be  $h_1 \in H$  and  $h_2 \in H$ , respectively. Consider the path  $\alpha_2^{h_1}$  obtained from  $\alpha_2$  via the right multiplication by  $h_1$ . This path begins at  $h_1$  and terminates at  $h_2 h_1$ . We have  $p(\alpha_1 \alpha_2^{h_1}) = \beta_1 \beta_2$ . Therefore  $\partial$  transforms the homotopic class of the path  $\beta_1 \beta_2$  into  $h_2 h_1 H^0 = (h_2 H^0)(h_1 H^0)$ , i.e.  $\partial$  is an antihomomorphism. Therefore,  $\iota \cdot \partial$  is a homomorphism.
17. Consider the action of these groups on the punctured spaces  $\mathbb{C}^n \setminus \{0\}$  and  $\mathbb{C}^{2n} \setminus \{0\}$ , respectively. (See hints to Problems 6 and 8).
18. For  $n > 3$  consider the  $SO_n(\mathbb{C})$ -action on the complex sphere in the space  $\mathbb{C}^n$  (see hint to Problem 7). Prove that the complex sphere is homotopically equivalent to the real sphere of the same dimension.

### § 4. The Derived Algebra and the Radical

This section is devoted to the part of the Lie group theory related to the construction of the derived algebra. We will define here two opposite types of Lie groups: solvable and semisimple. Any Lie group is constructed from groups of these two types in the sense that it possesses a connected solvable normal Lie subgroup the quotient group modulo which is semisimple.

**1°. The Commutator Group and the Derived Algebra.** Recall that the *commutator group* of a group  $G$  is the subgroup  $(G, G) = G'$  generated by all the commutators  $(x, y) = xyx^{-1}y^{-1}$ , where  $x, y \in G$ . This subgroup is normal and it is the smallest normal subgroup the quotient group modulo which is commu-

tative.  
generat  
the cor:

**Theo**  
with th  
subgroup

*Proo*  
algebra  
algebra  
morphi  
of  $f$  wi  
coincid  
Since  $C$   
Let  $t$   
that  $G'$

**Prot**  
in a ne  
1)  $g$   
2)  $g$   
Now  
Let  $g_i$   
[ $\xi, \eta$ ] =  
 $|t_i| < \epsilon$

The  $p$   
spaces  
and th  
For  
 $p: \tilde{G} \rightarrow$   
with  $t$   
that  $C$   
 $dp(\tilde{g}')$   
If  $G$   
Exerci

**Pro**  
**Pro**

2°.   
algebr  
is in a

tative. The *derived algebra* of a Lie algebra  $\mathfrak{g}$  is the subalgebra  $[\mathfrak{g}, \mathfrak{g}] = \mathfrak{g}'$  generated by the brackets  $[\xi, \eta]$ , where  $\xi, \eta \in \mathfrak{g}$ . It is the smallest ideal such that the corresponding quotient algebra is commutative.

**Theorem 1.** *For a connected Lie group  $G$ ,  $G'$  is a connected virtual Lie subgroup with the tangent algebra  $\mathfrak{g}'$ . If  $G$  is simply connected then  $G'$  is a genuine Lie subgroup.*

*Proof.* First, let  $G$  be a simply connected Lie group. Consider the quotient algebra  $\mathfrak{g}/\mathfrak{g}'$ . It is commutative and therefore may be identified with the tangent algebra of a suitable vector Lie group  $V$ . By Theorem 2.6 the canonical homomorphism  $\varphi: \mathfrak{g} \rightarrow \mathfrak{g}/\mathfrak{g}'$  is the differential of a homomorphism  $f: G \rightarrow V$ . The kernel of  $f$  will be denoted by  $H$ . It is a normal Lie subgroup whose tangent algebra coincides with the kernel of  $\varphi$ , i.e. with  $\mathfrak{g}'$ . Since  $G/H \cong V$  is commutative,  $H \supset G'$ . Since  $G$  and  $G/H$  are simply connected,  $H$  is connected (Theorem 3.4).

Let us show that  $G'$  contains a neighbourhood of the unit of  $H$ : this will imply that  $G' = H$ .

**Problem 1.** For any  $\xi, \eta \in \mathfrak{g}$  there exists a differentiable  $C^1$ -path  $g(t)$  in  $G$  defined in a neighbourhood of zero such that

- 1)  $g(0) = e, g'(0) = [\xi, \eta]$ ;
- 2)  $g(t)$  is a commutator in the group  $G$  for any  $t$ .

Now choose a basis  $\{\zeta_1, \dots, \zeta_m\}$  in the space  $\mathfrak{g}'$  over  $\mathbb{R}$  consisting of brackets. Let  $g_i(t)$ , where  $|t| < \varepsilon$ , be a path satisfying the conditions of Problem 1 for  $[\xi, \eta] = \zeta_i$ . Let  $U$  be the neighbourhood of zero in  $\mathbb{R}^m$  defined by the inequalities  $|t_i| < \varepsilon_i$ . Consider the map

$$f: U \rightarrow H, \quad \text{where } (t_1, \dots, t_m) \mapsto g_1(t) \dots g_m(t_m).$$

The properties of the paths  $g_i(t)$  imply that  $d_0 f$  is an isomorphism of tangent spaces. Hence,  $f(U)$  contains a neighbourhood of the unit of  $H$ , but  $f(U) \subset G'$  and therefore  $G'$  also contains a neighbourhood of the unit of  $H$ .  $\square$

For an arbitrary connected Lie group  $G$  consider its simply connected covering  $p: \tilde{G} \rightarrow G$ . By what we have already proved,  $\tilde{G}'$  is a connected Lie subgroup of  $\tilde{G}$  with the tangent algebra  $\tilde{\mathfrak{g}}'$ . However, it is obvious that  $G' = p(\tilde{G}')$ . It follows that  $G'$  is a connected virtual Lie subgroup of  $G$  with the tangent algebra  $dp(\tilde{\mathfrak{g}}') = \mathfrak{g}'$  (Problem 2.32). The theorem is proved.  $\square$

If  $G$  is not simply connected then  $G'$  might be not a genuine Lie subgroup (see Exercise 4).

**Problem 2.** If  $G$  is a connected Lie group and  $\mathfrak{g}' = \mathfrak{g}$ , then  $G' = G$ .

**Problem 3.**  $SL_n(K)$  coincides with its commutator group.

**2°. Malcev Closures.** In the tangent algebra of a Lie group may exist subalgebras that do not correspond to any Lie subgroups. The following example is in a sense a model one.

**Problem 4.** The one-dimensional subalgebra of the tangent algebra of the Lie group  $\mathbb{T}^n$ , generated by  $(ia_1, \dots, ia_n)$ , where  $a_1, \dots, a_n \in \mathbb{R}$ , is the tangent algebra of a Lie subgroup if and only if numbers  $a_1, \dots, a_n$  are commensurable.

Nevertheless, as we will soon see, there is always a Lie subgroup whose tangent algebra is only "a little bit" larger than the initial subalgebra.

**Theorem 2.** Let  $\{H_\nu\}$  be an arbitrary collection of Lie subgroups of  $G$ . Then  $H = \bigcap H_\nu$  is also a Lie subgroup and its tangent algebra coincides with  $\mathfrak{h} = \bigcap \mathfrak{h}_\nu$ .

**Problem 5.** Prove Theorem 2.

Now let  $\mathfrak{h}$  be an arbitrary subalgebra of the tangent algebra  $\mathfrak{g}$  of a Lie group  $G$ . By Theorem 2 there exists the smallest Lie subgroup of  $G$  such that its tangent algebra  $\mathfrak{h}^M$  contains  $\mathfrak{h}$ . The subalgebra  $\mathfrak{h}^M$  will be called the *Malcev closure* of  $\mathfrak{h}$ .

**Theorem 3.** ([43]) Let  $\mathfrak{h}$  be a subalgebra of the tangent algebra of the Lie group  $G$  and  $\mathfrak{h}^M$  its Malcev closure. Then  $(\mathfrak{h}^M)' = \mathfrak{h}'$ .

*Proof.* Apply Problem 1.25 to the adjoint representation of  $G$  with subspaces  $\mathfrak{h}$  and  $\mathfrak{h}'$  serving as  $U$  and  $W$ , respectively. We see that

$$H_1 = \{g \in G: (\text{Ad } g - E)\mathfrak{h} \subset \mathfrak{h}'\}$$

is a Lie subgroup in  $G$  and its tangent algebra is

$$\mathfrak{h}_1 = \{\xi \in \mathfrak{g}: (\text{ad } \xi)\mathfrak{h} \subset \mathfrak{h}'\}.$$

Clearly,  $\mathfrak{h} \subset \mathfrak{h}_1$ . Hence,  $\mathfrak{h}^M \subset \mathfrak{h}_1$ , i.e.  $[\mathfrak{h}^M, \mathfrak{h}] \subset \mathfrak{h}'$ . Now apply Problem 1.23 again taking  $\mathfrak{h}^M$  instead of  $U$ . We see that

$$H_2 = \{g \in G: (\text{Ad } g - E)\mathfrak{h}^M \subset \mathfrak{h}'\}$$

is a Lie subgroup and

$$\mathfrak{h}_2 = \{\xi \in \mathfrak{g}: (\text{ad } \xi)\mathfrak{h}^M \subset \mathfrak{h}'\}.$$

By what we have proved above,  $\mathfrak{h} \subset \mathfrak{h}_2$ . Hence,  $\mathfrak{h}^M \subset \mathfrak{h}_2$ , meaning that  $(\mathfrak{h}^M)' \subset \mathfrak{h}'$ .  $\square$

**Problem 6.** The Malcev closure of an ideal is an ideal.

**3°. Existence of Virtual Lie Subgroups.** Let us prove Theorem 2.8. Let  $\mathfrak{h}$  be a subalgebra of the tangent algebra of a Lie group  $G$ . Consider its Malcev closure  $\mathfrak{h}^M = \mathfrak{f}$ . By Theorem 3  $\mathfrak{f} \supset \mathfrak{h} \supset \mathfrak{f}' = \mathfrak{h}'$ . Let  $F$  be a connected Lie subgroup of  $G$  with the tangent algebra  $\mathfrak{f}$  and  $\tilde{F}$  its simply connected covering Lie group. Since  $\tilde{F}/\tilde{F}'$  is a vector group, it contains a connected Lie subgroup (a subspace of a vector space) with the tangent algebra  $\mathfrak{h}/\mathfrak{h}' \subset \mathfrak{f}/\mathfrak{f}'$ . (We identify the tangent algebra

of  $\tilde{F}$  with the Lie subalgebra  $\mathfrak{f}$ . During the covering map  $p: \tilde{F} \rightarrow F$  the Lie subalgebra  $\mathfrak{h}/\mathfrak{h}'$  is mapped to  $\mathfrak{f}/\mathfrak{f}'$ .

4°. Since  $k = 0, 1$

A group homomorphism  $\rho: \tilde{F} \rightarrow F$  is a Lie group homomorphism. The matrix  $\rho_j$  is a Lie group homomorphism.

is a homomorphism. We have

Similar definitions

A Lie subalgebra  $\mathfrak{h}$  of  $\mathfrak{g}$  is a Lie subalgebra of  $\mathfrak{g}$ .

Example. Let  $\mathfrak{h}_k$  be a Lie subalgebra of  $\mathfrak{g}$  for  $j = 1, \dots, n$  with  $\mathfrak{h}_k$

of  $\tilde{F}$  with  $\mathfrak{f}$ ). Therefore, the group  $\tilde{F}$  itself contains a connected Lie subgroup  $\tilde{H}$  with the tangent algebra  $\mathfrak{h}$ . The image of this subgroup in  $F$  is the desired virtual Lie subgroup of  $G$ .  $\square$

During the proof we have actually obtained a description of arbitrary connected virtual Lie subgroups. Namely, any connected virtual Lie subgroup  $H$  of a Lie group  $G$  may be obtained as follows: there exists a connected Lie subgroup  $F$  of  $G$  and a connected Lie subgroup  $\tilde{H}$  of the simply connected covering Lie group  $\tilde{F}$  containing its commutator subgroup such that  $H = p(\tilde{H})$ , where  $p: \tilde{F} \rightarrow F$  is the covering homomorphism. (Clearly,  $\tilde{H}$  is the simply connected covering Lie group for  $H$ .)

**4°. Solvable Lie Groups.** Recall that the *iterated commutator groups*  $G^{(k)}$  ( $k = 0, 1, 2, \dots$ ) of  $G$  are defined by induction:

$$G^{(0)} = G, \quad G^{(1)} = G', \quad G^{(k+1)} = (G^{(k)})'.$$

A group  $G$  is called *solvable* if there exists an  $m$  such that  $G^{(m)} = \{e\}$ . Any subgroup and any quotient group of a solvable group is solvable. Conversely, if a normal subgroup  $N \subset G$  and the quotient group  $G/N$  are solvable then so is  $G$ .

A Lie group is called *solvable* if it is solvable as an abstract group.

*Example 1.* The group  $B_n = B_n(K)$  of invertible (upper) triangular  $n \times n$  matrices over  $K$ . Denote by  $B_{n,k}$  ( $k = 0, 1, \dots, n$ ) its subgroup consisting of the matrices  $A = (a_{ij})$  with  $a_{ij} = \delta_{ij}$  for  $j - i < k$ . Clearly,  $B'_n \subset B_{n,1}$  and the map

$$A \mapsto (a_{1,k+1}, a_{2,k+2}, \dots, a_{n-k,n}) \tag{1}$$

is a homomorphism of  $B_{n,k}$  onto the vector group  $K^{n-k}$ . The kernel of this homomorphism coincides with  $B_{n,k+1}$ . Therefore  $B'_{n,k} \subset B_{n,k+1}$ . Since  $B_{n,n} = \{e\}$ , we have  $B_n^{(n)} = \{e\}$ .

Similarly, the *iterated derived algebras*  $\mathfrak{g}^{(k)}$  ( $k = 0, 1, 2, \dots$ ) of a Lie algebra  $\mathfrak{g}$  are defined by induction as:

$$\mathfrak{g}^{(0)} = \mathfrak{g}, \quad \mathfrak{g}^{(1)} = \mathfrak{g}', \quad \mathfrak{g}^{(k+1)} = (\mathfrak{g}^{(k)})'.$$

A Lie algebra  $\mathfrak{g}$  is called *solvable* if there exists an  $m$  such that  $\mathfrak{g}^{(m)} = 0$ . Subalgebras and quotient algebras of a solvable Lie algebra are solvable. Conversely, if an ideal  $\mathfrak{n} \subset \mathfrak{g}$  and the quotient algebra  $\mathfrak{g}/\mathfrak{n}$  are solvable then so is  $\mathfrak{g}$ .

*Example 2.* The tangent algebra of  $B_n(K)$  is the Lie algebra  $\mathfrak{b}_n = \mathfrak{b}_n(K)$  of all upper triangular  $n \times n$  matrices over  $K$ . Let us prove that  $\mathfrak{b}_n$  is solvable. Let  $\mathfrak{b}_{n,k}$  ( $k = 0, 1, \dots, n$ ) be its subalgebra consisting of matrices  $X = (x_{ij})$  with  $x_{ij} = 0$  for  $j - i < k$ . Clearly,  $\mathfrak{b}'_n \subset \mathfrak{b}_{n,1}$  and the map (1) is a homomorphism of  $\mathfrak{b}_{n,k}$  onto a commutative Lie algebra  $K^{n-k}$ . The kernel of this homomorphism coincides with  $\mathfrak{b}_{n,k+1}$ . Therefore  $\mathfrak{b}'_{n,k} \subset \mathfrak{b}_{n,k+1}$ . Since  $\mathfrak{b}_{n,n} = 0$ , we have  $\mathfrak{b}_n^{(n)} = 0$ .

The induction shows that the iterated commutator group  $G^{(k)}$  of a connected Lie group  $G$  is its connected virtual Lie subgroup with the tangent algebra  $\mathfrak{g}^{(k)}$ . This implies

**Theorem 4.** *A connected Lie group  $G$  is solvable if and only if so is its tangent algebra. More precisely,  $G^{(m)} = \{e\}$  if and only if  $\mathfrak{g}^{(m)} = 0$ .*

**Problem 7.** Any nontrivial solvable Lie algebra splits into a semidirect sum of an ideal of codimension 1 and a 1-dimensional subalgebra.

Applying Problem 2.39 and induction in  $\dim \mathfrak{g}$  we see that for any solvable Lie algebra  $\mathfrak{g}$  there exists a simply connected Lie group whose tangent algebra is isomorphic to  $\mathfrak{g}$ . Simultaneously we establish the following fact.

**Problem 8.** Any nontrivial simply connected solvable Lie group decomposes into a semidirect product of a normal Lie subgroup of codimension 1 and a one-dimensional Lie subgroup (isomorphic to  $K$ ).

**5°. Lie's Theorem.** The most important tool in the study of solvable Lie groups is

**Theorem 5 (Lie's theorem).** *Let  $R: G \rightarrow GL(V)$  be a complex linear representation of a connected solvable (real or complex) Lie group  $G$ . There exists a one-dimensional subspace  $U \subset V$  invariant with respect to  $R(G)$ .*

Before we prove this theorem let us introduce certain definitions and prove several simple statements on linear representations of abstract groups.

Let  $R: G \rightarrow GL(V)$  be a linear representation (over an arbitrary field). For any character  $\chi$  of  $G$  (see definition of character in 1.4) set

$$V_\chi(G) = \{v \in V: R(g)v = \chi(g)v \text{ for all } g \in G\}. \quad (2)$$

If  $V_\chi(G) \neq 0$  then  $\chi$  is called a *weight* of  $R$ , the subspace  $V_\chi(G)$  a *weight subspace* and its nonzero elements the *weight vectors* corresponding to  $\chi$ . In other words, the weights of a representation are the characters that occur in it as one-dimensional subrepresentations and the weight vectors are the vectors generating one-dimensional invariant subspaces.

**Problem 9.** The weight subspaces corresponding to different weights are linearly independent.

This implies, in particular, that a linear representation may only have a finite number of weights.

Now let  $H$  be a normal subgroup of  $G$ .

**Problem 10.** For any character  $\chi$  of  $H$  and any  $g \in G$  we have

$$R(g)V_\chi(H) = V_{\chi^g}(H),$$

where  $\chi^g(h) = \chi(g^{-1}hg)$  for  $h \in H$ .

Therefore the operators corresponding to elements of  $G$  can only permute weight subspaces of  $H$ .

*Proof* of Theorem 5 will be carried out by induction in  $\dim G$ . Suppose that  $\dim G > 0$  and that the theorem holds for groups whose dimension is less than  $\dim G$ . Passing to the simply connected covering Lie group we can reduce the proof to the case when  $G$  is simply connected. In this case by Problem 8 we have

$$G = H \times P,$$

where  $H$  is a normal Lie subgroup of codimension 1 and  $P$  is a one-dimensional Lie subgroup.

By inductive hypothesis there exists a one-dimensional subspace of  $V$  invariant with respect to  $R(H)$ . This means that  $V_\chi(H) \neq 0$  for a character  $\chi$  of  $H$ . Since the operators  $R(g)$ ,  $g \in G$ , can only permute weight subspaces of  $H$  and since  $G$  is connected, then  $V_\chi(H)$  is invariant with respect to  $R(G)$ , hence with respect to  $dR(\mathfrak{g})$ .

Now let  $\xi$  be a nonzero element of the tangent algebra of  $P$  and  $U$  a one-dimensional subspace of  $V_\chi(H)$  invariant with respect to  $dR(\xi)$ . Then it is also invariant with respect to  $R(P)$ , hence with respect to  $R(G)$ . The theorem is proved.  $\square$

**Problem 11 (Corollary).** Under the conditions of the theorem there exists a basis of  $V$  in which all the operators  $R(g)$ ,  $g \in G$ , are expressed by (upper) triangular matrices.

#### 6°. The Radical. Semisimple Lie Groups.

**Problem 12.** The sum of solvable ideals of a Lie algebra is a solvable ideal.

It follows, that in any Lie algebra  $\mathfrak{g}$  there exists the largest solvable ideal. It is called the *radical* of  $\mathfrak{g}$ . We will denote it by  $\text{rad } \mathfrak{g}$ .

**Theorem 6.** In any Lie group  $G$  there is the largest connected solvable normal Lie subgroup. Its tangent algebra coincides with  $\text{rad } \mathfrak{g}$ .

*Proof.* Consider the Malcev closure  $(\text{rad } \mathfrak{g})^M$ . By Theorem 3  $((\text{rad } \mathfrak{g})^M)' = (\text{rad } \mathfrak{g})'$ . Hence,  $(\text{rad } \mathfrak{g})^M$  is a solvable Lie algebra. By Problem 6  $(\text{rad } \mathfrak{g})^M$  is an ideal. Since  $\text{rad } \mathfrak{g}$  is the largest solvable ideal of  $\mathfrak{g}$ , then  $(\text{rad } \mathfrak{g})^M = \text{rad } \mathfrak{g}$ . This means that there exists a connected Lie subgroup  $R \subset G$  such that its tangent algebra coincides with  $\text{rad } \mathfrak{g}$ .

The definition of  $\text{rad } \mathfrak{g}$  implies that  $\text{rad } \mathfrak{g}$  is invariant with respect to all automorphisms of  $\mathfrak{g}$ . Hence,  $R$  is invariant with respect to all automorphisms of  $G$ . In particular,  $R$  is normal. By Theorem 4 it is solvable.

Any connected solvable normal Lie subgroup  $H \subset G$  must be contained in  $R$  since its tangent algebra  $\mathfrak{h}$  being a solvable ideal of  $\mathfrak{g}$  is contained in  $\text{rad } \mathfrak{g}$ . Thus,  $R$  is the largest connected solvable normal Lie subgroup of  $G$ .  $\square$

The subgroup satisfying the hypotheses of Theorem 5 is called the *radical* of the Lie group  $G$ . We will denote it by  $\text{Rad } G$ .

A Lie group  $G$  (a Lie algebra  $\mathfrak{g}$ ) is called *semisimple* if  $\text{Rad } G = \{e\}$  (resp.  $\text{rad } \mathfrak{g} = 0$ ). Obviously, a Lie group is semisimple if and only if its tangent algebra is semisimple. For any Lie group  $G$  (resp. Lie algebra  $\mathfrak{g}$ ) the quotient group  $G/\text{Rad } G$  (resp. the quotient algebra  $\mathfrak{g}/\text{rad } \mathfrak{g}$ ) is semisimple.

**Problem 13.** A Lie algebra  $\mathfrak{g}$  is semisimple if and only if it has no commutative ideals.

In Chapters IV and V we will show that the classical Lie groups  $\text{SL}_n(K)$ ,  $\text{SO}_n(K)$  for  $n \geq 3$ ,  $\text{Sp}_n(K)$  and several other groups are semisimple. The theory of semisimple Lie groups is the most difficult and significant part of the Lie group theory.

**7°. Complexification.** Complex Lie algebras have a simpler structure than real ones. Therefore the usual way to study real Lie algebras is to complexify them. In order to prove anything in this way we should know which properties of a Lie algebra are preserved under the complexification. In this section we will prove that solvability and semisimplicity are among these properties.

Let  $V(\mathbb{C}) = V \otimes_{\mathbb{R}} \mathbb{C}$  be the *complexification* of a real vector space  $V$ . Any vector  $z \in V(\mathbb{C})$  can be uniquely presented in the form  $z = x + iy$ , where  $x, y \in V$ . The vector  $\bar{z} = x - iy$  is called the *complex conjugate* to  $z$ . The complex conjugation is an antilinear transformation of the space  $V(\mathbb{C})$ . Therefore if  $W \subset V(\mathbb{C})$  is a subspace then so is  $\bar{W}$ .

**Problem 14.** A subspace  $W \subset V(\mathbb{C})$  is the complexification of a subspace  $U \subset V$  if and only if  $\bar{W} = W$ .

Now let  $\mathfrak{g}(\mathbb{C}) = \mathfrak{g} \otimes_{\mathbb{R}} \mathbb{C}$  be the complexification of a real Lie algebra  $\mathfrak{g}$ . Clearly, a subspace  $\mathfrak{h} \subset \mathfrak{g}$  is a subalgebra (resp. ideal) if and only if its complexification  $\mathfrak{h}(\mathbb{C})$  is a subalgebra (ideal) of  $\mathfrak{g}(\mathbb{C})$ . Obviously, the complex conjugation is an antilinear automorphism of  $\mathfrak{g}(\mathbb{C})$ .

**Problem 15.**  $(\mathfrak{g}(\mathbb{C}))' = \mathfrak{g}'(\mathbb{C})$

This implies that  $\mathfrak{g}(\mathbb{C})$  is solvable if and only if so is  $\mathfrak{g}$ .

**Problem 16.**  $\text{rad } \mathfrak{g}(\mathbb{C}) = (\text{rad } \mathfrak{g})(\mathbb{C})$ .

It follows, that  $\mathfrak{g}(\mathbb{C})$  is semisimple if and only if so is  $\mathfrak{g}$ .

### Exercises

- 1)  $(\text{GL}_n(K))' = \text{SL}_n(K)$ .
- 2)  $(\text{O}_n(K))' = \text{SO}_n(K)$ .
- 3)  $U'_n = \text{SU}_n$ .
- 4) Let  $H$  be the Lie group of  $3 \times 3$  unitriangular real matrices and  $G = (H \times \mathbb{T})/N$ , where  $N$  is the cyclic subgroup generated by

$$\left( \left( \begin{pmatrix} 1 & 0 & 1 \\ 0 & 1 & 0 \\ 0 & 0 & 1 \end{pmatrix}, c \right), \text{ where } c \in \mathbb{T}. \right.$$

If  $c$  is an element of infinite order of  $\mathbb{T}$  then  $G'$  is not a Lie subgroup.

- 5) A subspace of the tangent algebra of  $\mathbb{T}^n$  is the tangent space to a Lie subgroup if and only if it is generated by vectors of the form  $(ia_1, \dots, ia_n)$ , where  $a_1, \dots, a_n \in \mathbb{Q}$ .
- 6) Let  $\mathfrak{a}$  and  $\mathfrak{b}$  be subalgebras of the tangent algebra of a Lie group such that  $[\mathfrak{a}, \mathfrak{b}] \subset \mathfrak{a} \cap \mathfrak{b}$ . Let  $\mathfrak{a}^M, \mathfrak{b}^M$  be their Malcev closures. Then  $[\mathfrak{a}^M, \mathfrak{b}^M] = [\mathfrak{a}, \mathfrak{b}]$ . (Here  $[\mathfrak{a}, \mathfrak{b}]$  is the subspace generated by the brackets  $[\xi, \eta]$ , where  $\xi \in \mathfrak{a}, \eta \in \mathfrak{b}$ ).
- 7) The Malcev closure of a commutative subalgebra is a commutative subalgebra.
- 8) If a Lie group (resp. Lie algebra) is not semisimple it has a connected commutative normal Lie subgroup (resp. a commutative ideal) of positive dimension.
- 9) Let  $R$  be a connected solvable normal Lie subgroup of  $G$ . If  $G/R$  is semisimple then  $R = \text{Rad } G$ .
- 10)  $\text{SL}_n(K)$  is semisimple.
- 11) A direct product of semisimple Lie groups is a semisimple Lie group.
- 12) Let  $U$  be a subspace of a complex vector space  $V$ . The radical of the Lie group

$$\text{GL}(V; U) = \{A \in \text{GL}(V) : AU \subset U\}$$

consists of all the transformations  $A \in \text{GL}(V; U)$  that act as multiplications by scalars on  $U$  and on  $V/U$ .

- 13) The radical of a complex Lie group coincides with the radical of this group considered as a real Lie group.
- 14) Any nontrivial connected solvable real Lie group has a connected normal Lie subgroup of codimension 1.
- 15) Let  $G$  be a connected solvable real Lie group and  $H$  its connected solvable Lie subgroup of codimension 1. Then  $G = H \rtimes P$ , where  $P$  is a connected one-dimensional Lie subgroup.

### Hints to Problems

1. Let  $x(t)$  and  $y(t)$ , where  $0 \leq t < \varepsilon$ , be differentiable paths in  $G$  such that  $x(0) = y(0) = e$ ,  $x'(0) = \xi$ ,  $y'(0) = \eta$ . Then we may take

$$g(t) = \begin{cases} (x(\sqrt{t}), y(\sqrt{t})) & \text{for } t \geq 0 \\ (x(\sqrt{|t|}), y(\sqrt{|t|}))^{-1} & \text{for } t \leq 0. \end{cases}$$

3. Let  $E_{ij}$  be a matrix unit, i.e. its  $(i, j)$ -th entry is 1 and the other entries are zeros. Clearly,

$$[E_{ii} - E_{jj}, E_{ij}] = 2E_{ij}$$

$$[E_{ij}, E_{ji}] = E_{ii} - E_{jj}$$

for  $i \neq j$ . This implies that  $\mathfrak{sl}_n(K)' = \mathfrak{sl}_n(K)$ , hence  $\text{SL}_n(K)' = \text{SL}_n(K)$ .

4. If the required Lie subgroup exists, it is the image of  $\mathbb{R}$  under the homomorphism  $\mathbb{R} \rightarrow \mathbb{T}^n$  such that its differential maps 1 into  $(ia_1, \dots, ia_n)$ . This homomorphism is of the form

$$x \mapsto (e^{ia_1 x}, \dots, e^{ia_n x}).$$

Further, use Problem 1.14.

5. For a finite number of subgroups the statement is just the contents of Problem 1.23. In the general case the subalgebra  $\bigcap \mathfrak{h}_v$  coincides with the intersection of a finite number of subalgebras, say  $\mathfrak{h}_{v_1}, \dots, \mathfrak{h}_{v_k}$ , and by the above it is the tangent algebra of the Lie subgroup  $\hat{H} = H_{v_1} \cap \dots \cap H_{v_k}$ . For any  $v$  the Lie subgroup  $\hat{H} \cap H_v$  has the same tangent algebra as  $\hat{H}$ . Hence  $\hat{H} \cap H_v$  is contained in  $\hat{H}$  and contains  $H^0$  and therefore so is and does  $H$ . Thus  $H$  is a Lie subgroup and its tangent algebra coincides with  $\bigcap \mathfrak{h}_v$ .
6. Clearly, if  $a$  is an automorphism of the Lie group  $G$ , then  $(da(\mathfrak{h}))^M = da(\mathfrak{h}^M)$  for any Lie subalgebra  $\mathfrak{h} \subset \mathfrak{g}$ . In particular,  $((\text{Ad } g)\mathfrak{h})^M = (\text{Ad } g)\mathfrak{h}^M$ . Further, use the fact that  $\mathfrak{h}$  is an ideal if and only if  $(\text{Ad } g)\mathfrak{h} = \mathfrak{h}$  for any  $g \in G^0$ .
7. For an ideal take any subspace of codimension 1 containing the derived algebra and for a subalgebra take any complementary subspace.
9. The proof is similar to that of the theorem on linear independence of eigensubspaces of a linear operator.
11. Take a one-dimensional invariant subspace  $U \subset V$  which exists due to the theorem and consider the quotient representation of  $G$  in  $V/U$ . Apply the theorem again to this representation, etc.
13. Consider the last nonzero iterated derived algebra of  $\text{rad } \mathfrak{g}$ .
14. If  $\overline{W} = W$  then with any  $z = x + iy$  ( $x, y \in V$ ) the subspace  $W$  contains both  $x = \frac{1}{2}(z + \bar{z})$  and  $y = \frac{1}{2i}(z - \bar{z})$ , which means that  $W$  is the complexification of  $U = W \cap V$ .
16. Notice that  $\overline{\text{rad } \mathfrak{g}(\mathbb{C})}$  is a solvable ideal of  $\mathfrak{g}(\mathbb{C})$  hence is contained in  $\text{rad } \mathfrak{g}(\mathbb{C})$ .

## Chapter 2

### Algebraic Varieties

The objects that occur in this chapter (vector spaces, algebras, algebraic varieties, etc.) are considered over a fixed ground field  $K$ . In subsections 1.5–3.3 it is assumed to be algebraically closed<sup>1</sup>. Sometimes we require that it be of zero characteristic. The reader, however, would not lose much by restricting himself to the cases  $K = \mathbb{C}$  or (where the algebraic closedness is not required)  $K = \mathbb{R}$ . Only these cases are needed for future applications to the Lie group theory and we only consider more general fields in order to elucidate the algebraic nature of the theory discussed.

Denote by  $\mathbb{A}^n$  (resp.  $\mathbb{P}^n$ ) the  $n$ -dimensional affine (resp. projective) space over  $K$ . The point of  $\mathbb{A}^n$  with coordinates  $X_1, \dots, X_n$  is denoted by  $(X_1, \dots, X_n)$ . A point of  $\mathbb{P}^n$  with homogeneous coordinates  $U_0, U_1, \dots, U_n$  is denoted by  $(U_0:U_1:\dots:U_n)$ .

Hereafter the word “algebra” means “commutative associative algebra with unit” except the subsection 3.6 where arbitrary algebras are also considered. Subalgebras are supposed to contain unit, homomorphisms to transform the unit into the unit.

$QA$  stands for the full quotient algebra of an algebra  $A$ , i.e. the quotient ring of  $A$  with respect to the multiplicative system consisting of all elements that are not zero divisors (see [44]), considered as an algebra over the ground field. If, in particular,  $A$  is an algebra without zero divisors then  $QA$  is a field.

If  $L_1, L_2, \dots$  are some capitals then  $A[L_1, L_2, \dots]$  denotes the polynomial algebra of  $L_1, L_2, \dots$  with coefficients in  $A$ .

#### § 1. Affine Algebraic Varieties

In subsections 1°–4° the ground field  $K$  is an arbitrary infinite field.

**1°. Embedded Affine Varieties.** An *algebraic variety* in  $\mathbb{A}^n$  or an *embedded affine algebraic variety* is a subset in  $\mathbb{A}^n$  defined by a system of equations

$$f(X_1, \dots, X_n) = 0 \quad (f \in S), \quad (1)$$

---

<sup>1</sup> In many cases this assumption is superfluous but we decided not to overburden our narrative with a perpetual change of scenery.

where  $S$  is a (not necessarily finite) set of polynomials. An algebraic variety defined by system (1) will be denoted by  $M(S)$ .

The collection  $I$  of polynomials of the form  $\sum g_i f_i$ , where  $g_i \in K[X_1, \dots, X_n]$  and  $f_i \in S$ , is an ideal of the algebra  $K[X_1, \dots, X_n]$ . It is the smallest ideal that contains  $S$ . We will say that the ideal  $I$  is *generated by the set  $S$*  or that  $S$  is a *system of generators of the ideal  $I$* . Evidently,  $M(S) = M(I)$ .

An algebra is *noetherian* if one of the following conditions is satisfied

- each its ideal is finitely generated;
- any nondescending chain of its ideals  $I_1 \subset I_2 \subset \dots$  stabilizes, i.e.  $I_m = I_{m+1} = \dots$  for some  $m$ .

**Problem 1.** Conditions a) and b) are equivalent.

**Theorem 1** (Hilbert's ideal basis theorem). *If  $R$  is noetherian then so is  $R[X]$ . In particular,  $K[X_1, \dots, X_n]$  is noetherian.*

*Proof:* see e.g. [8].

**Problem 2 (Corollary).** Any affine algebraic variety can be determined by a finite system of equations.

Let  $I$  be an ideal of  $K[X_1, \dots, X_n]$  and  $A = K[X_1, \dots, X_n]/I$ . The natural homomorphism of  $K[X_1, \dots, X_n]$  onto  $A$  will be denoted by  $\pi$ ; put  $\pi(X_i) = x_i$ . The algebra  $A$  is generated over  $K$  by  $x_1, \dots, x_n$ , i.e. any element of  $A$  is presented (in general, non uniquely) as a polynomial in  $x_1, \dots, x_n$  with coefficients in  $K$ . We will express this fact as follows:  $A = K[x_1, \dots, x_n]$ . Clearly, if  $f \in I$ , then  $f(x_1, \dots, x_n) = 0$  and for any homomorphism  $\varphi: A \rightarrow K$  we have  $f(\varphi(x_1), \dots, \varphi(x_n)) = 0$ . This means that for any homomorphism  $\varphi: A \rightarrow K$  the point  $(\varphi(x_1), \dots, \varphi(x_n))$  belongs to the variety  $M(I)$ .

**Problem 3.** This correspondence between the homomorphisms  $A \rightarrow K$  and the points of  $M(I)$  is one to one.

Now let  $A = K[x_1, \dots, x_n]$  be an algebra generated by its elements  $x_1, \dots, x_n$ . There is the unique homomorphism  $\pi: K[X_1, \dots, X_n] \rightarrow A$  such that  $\pi(X_i) = x_i$ . If  $I = \ker \pi$ , then  $A = K[X_1, \dots, X_n]/I$ . By Problem 3 the homomorphisms  $A \rightarrow K$  are in one-to-one correspondence with the points of  $M(I)$ . Thus we may speak about an *affine algebraic variety defined by an algebra with a fixed finite system of generators*.

Different ideals (algebras) may define the same variety. For example, the ideals  $(X)$  and  $(X^2)$  in  $K[X]$  define the subvariety in  $\mathbb{A}^1$  that consists of the single point  $(0)$ . Among all the ideals defining a given variety  $M$  there is the largest one, namely, the ideal generated by all polynomials that vanish on  $M$ .

Let  $M \subset \mathbb{A}^n$  be an algebraic variety. For any polynomial  $f \in K[X_1, \dots, X_n]$  denote by  $f|_M$  its restriction (as of a function) onto  $M$ . The map  $f \mapsto f|_M$  is a homomorphism of  $K[X_1, \dots, X_n]$  into the algebra of functions on  $M$  and the kernel of this homomorphism is  $I(M)$ . Therefore, elements of the algebra

$$K[M] = K[X_1, \dots, X_n]/I(M) \quad (2)$$

may be  
on  $M$  &  
the coo

**Prob**  
a uniqu

In th  
otherw

An e  
does n  
divisor

Let .  
n-dime  
may co

in  $\mathbb{A}^n(I$

2°. I  
variety  
may b  
polync  
 $x \in M$

As a  
functio

(Here g  
that if  
homor

**Pro**  
unique

Thu  
as to d

Clea  
and (g  
an inv  
a poly  
algebr

The  
tract)  
will be  
cally, &  
howev

may be interpreted as functions on  $M$ . These functions will be called *polynomials on  $M$*  and the algebra  $K[M]$  will be called *the algebra of polynomials on  $M$*  or *the coordinate algebra of  $M$* .

**Problem 4.** Suppose  $A = K[x_1, \dots, x_n]$  defines a variety  $M$ . Then there exists a unique homomorphism  $\rho: A \rightarrow K[M]$  such that  $\rho(x_i) = X_i|_M$ .

In the sequel, as long as it is clear what  $M$  is meant and unless mentioned otherwise we will write  $x_i$  for  $X_i|_M$ ; then  $K[M] = K[x_1, \dots, x_n]$ .

An element  $a \in A$  is called *nilpotent* if  $a^k = 0$  for a certain  $k$ . Clearly,  $K[M]$  does not have nilpotent elements. (When talking about algebras without zero divisors or nilpotent elements one obviously has in mind nonzero elements.)

Let  $L$  be a field extension of  $K$ . The space  $\mathbb{A}^n$  is naturally embedded into the  $n$ -dimensional affine space  $\mathbb{A}^n(L)$  over  $L$ . For any algebraic variety  $M \subset \mathbb{A}^n$  one may consider the algebraic variety

$$M(L) = \{x \in \mathbb{A}^n(L): f(x) = 0 \text{ for all } f \in I(M)\}$$

in  $\mathbb{A}^n(L)$ . Obviously,  $M = M(L) \cap \mathbb{A}^n$ .

**2°. Morphisms.** A morphism of an algebraic variety  $M \subset \mathbb{A}^n$  into an algebraic variety  $N \subset \mathbb{A}^m$  is any polynomial map  $f: M \rightarrow N$  i.e. a map that (in coordinates) may be determined by polynomials. More precisely, it means that there are polynomials  $f_1, \dots, f_m \in K[X_1, \dots, X_n]$  such that the map  $f$  transforms a point  $x \in M$  into the point of the variety  $N$  with coordinates  $f_1(x), \dots, f_m(x)$ .

As any map, a morphism  $f: M \rightarrow N$  induces a homomorphism of algebras of functions defined by the formula

$$(f^*g)(x) = g(f(x)) \quad (3)$$

(Here  $g$  is a function on  $N$ ,  $x \in M$ ). The definition of the morphism clearly implies that if  $g$  is a polynomial on  $N$ , then  $f^*g$  is a polynomial on  $M$ . So we get a homomorphism of algebras:  $f^*: k[N] \rightarrow k[M]$ .

**Problem 5.** For any algebra homomorphism  $\varphi: K[N] \rightarrow K[M]$  there exists a unique morphism  $f: M \rightarrow N$  such that  $f^* = \varphi$ .

Thus, to define a morphism of embedded affine algebraic varieties is the same as to define a homomorphism of algebras of polynomials on these varieties.

Clearly, the product  $gf$  of morphisms  $f: M \rightarrow N$  and  $g: N \rightarrow P$  is a morphism and  $(gf)^* = f^*g^*$ . A morphism  $f: M \rightarrow N$  is called an *isomorphism* if there exists an inverse morphism  $f^{-1}: N \rightarrow M$ , i.e. if  $f$  is bijective and the inverse map is also a polynomial one. This is equivalent to the fact that  $f^*$  is an isomorphism of algebras.

The class of isomorphic embedded affine algebraic varieties is called an (*abstract*) *affine algebraic variety* (or, in short, *affine variety*) and its representatives will be called *embeddings* of this variety into the affine space, or *models*. Practically, an affine variety is identified with one of its models (always having in mind, however, the possibility to pass to any other model).

A *polynomial on an affine variety* is a function which is a polynomial on a model of this variety (it does not matter on which one). The polynomials on an affine variety  $M$  constitute the algebra denoted by  $K[M]$ . Similarly, a *morphism* or a *polynomial map of affine varieties* is a map which is a morphism of their models (it does not matter of which ones).

By Problem 3 there is a one-to-one correspondence between the points of an affine variety  $M$  and algebra homomorphisms of  $K[M]$  into  $K$ . Explicitly, to each point  $x \in M$  the homomorphism  $\varphi_x$  corresponds which assigns to each polynomial  $f \in K[M]$  its value at  $x$ :

$$\varphi_x: f \mapsto f(x) \quad (f \in K[M]). \quad (4)$$

It is clear from the above that to determine an affine variety  $M$  is the same as to determine the algebra  $K[M]$  and to determine an embedding of  $M$  in an affine space is the same as to choose a system of generators in the algebra  $K[M]$ . To determine a morphism of affine varieties is the same as to determine a homomorphism of their polynomial algebras. This makes it principally possible to translate any statement about affine varieties from the geometric language into the algebraic one and, the other way around, to translate statements on polynomial algebras into the geometric language.

Thus, the question arises what are the algebras that are algebras of polynomials on affine varieties?

An exact answer to this question in the case of an algebraically closed  $K$  will be given in n. 7°. For the time being we can say that they can only be finitely generated algebras without nilpotent elements. In algebraic geometry more general geometric objects (affine schemes) are also considered which correspond to arbitrary finitely generated algebras. However, for our purposes affine varieties in the above "naive" sense will do.

Let  $L$  be a field extension of  $K$ . Clearly, any morphism  $M \rightarrow N$  of embedded affine varieties extends to a morphism  $M(L) \rightarrow N(L)$  determined by the same polynomials. Therefore we may speak about an abstract affine variety  $M(L)$  over  $L$  determined by an abstract affine variety  $M$  over  $K$  and about an embedding  $M \subset M(L)$ .

**3°. Zariski Topology.** Let us consider algebraic varieties as *closed subsets* of  $\mathbb{A}^n$ .

**Problem 6.** This system of closed subsets determines a topology in  $\mathbb{A}^n$  (i.e. the intersection of closed subsets and the union of a finite number of closed subsets are closed).

This topology in  $\mathbb{A}^n$  is called the *Zariski topology*. Clearly, a point is closed in the Zariski topology.

The Zariski topology of  $\mathbb{A}^n$  induces a topology on any algebraic variety  $M \subset \mathbb{A}^n$  which is called the *Zariski topology* on  $M$ . According to this definition the closed subsets are distinguished in  $M$  by systems of equations of the form  $f(x) = 0$ , where  $f \in K[M]$ . In particular, the Zariski topology on  $M$  is defined

by  $K[M]$ , and that is why we may speak about the *Zariski topology* on an abstract affine variety. Clearly, morphisms of affine varieties are continuous in Zariski topology. Closed subsets  $N$  of an affine variety  $M$  are canonically endowed with an affine variety structure so that

$$K[N] = K[M]/I_M(N),$$

where  $I_M(N)$  is the ideal of  $K[M]$  consisting of the polynomials that vanish on  $N$ .

Notice that the Zariski topology on  $\mathbb{A}^{n+m}$  does not coincide with the direct product topology on  $\mathbb{A}^n \times \mathbb{A}^m$  (e.g. the set in  $\mathbb{A}^2$  determined by the equation  $X_1 = X_2$  is closed but it is not closed in  $\mathbb{A}^1 \times \mathbb{A}^1$ ).

In the sequel, unless otherwise stated, all the topological terms, excluding connectedness and simple connectedness are referred to the Zariski topology.

The space  $\mathbb{A}^n \times \mathbb{A}^m$  is supposed to be endowed with the Zariski topology of the space  $\mathbb{A}^{n+m}$ .

A topological space  $X$  is *noetherian* if it satisfies the descending chain condition for closed subsets.

**Problem 7.** A subspace of a noetherian space is noetherian.

**Problem 8.** The space  $\mathbb{A}^n$  endowed with the Zariski topology is a noetherian topological space.

This implies that any affine variety is a noetherian topological space.

A topological space  $M$  is *irreducible* if it is nonempty and one of the following three conditions is satisfied:

- a) any nonempty open set is dense in  $M$ ;
- b) any two nonempty open sets intersect;
- c) it is impossible to present  $M$  as a union of two of its proper closed subsets.

**Problem 9.** Prove the equivalence of these conditions.

**Theorem 2.** Any noetherian topological space  $M$  can be presented as a union of a finite number of closed irreducible subsets  $M_i$ , so that  $M_i \not\subset M_j$  for  $i \neq j$ . This decomposition is unique up to a renumbering of the  $M_i$ .

The subsets  $M_i$  defined in Theorem 2 are called *irreducible components* of  $M$ .

**Problem 10.** Prove Theorem 2.

**Problem 11.** An affine variety  $M$  is irreducible if and only if  $K[M]$  does not have zero divisors. More precisely, zero divisors in  $K[M]$  are the polynomials which vanish on an irreducible component of  $M$ . In particular,  $\mathbb{A}^n$  is irreducible.

The *closure* of a subset  $M$  in a topological space will be denoted by  $\overline{M}$ .

**Problem 12.** Let  $M$  be a subset of a noetherian topological space. If  $M = \bigcup_i M_i$  is the decomposition of  $M$  into irreducible components, then  $\overline{M} = \bigcup_i \overline{M_i}$  is the decomposition of  $\overline{M}$  into irreducible components. In particular,  $M$  is irreducible if and only if so is  $\overline{M}$ .

Let  $M$  be an affine variety. The open subsets of the form

$$M_h = \{x \in M : h(x) \neq 0\} \quad (h \in K[M])$$

are called *principal open subsets* of  $M$ . Clearly,

$$M_{h_1} \cap M_{h_2} = M_{h_1 h_2}$$

It follows from Problem 11 that  $M_h$  is dense in  $M$  if and only if  $h$  is not a zero divisor in  $K[M]$ .

**Problem 13.** The principal open subsets of an affine variety constitute a base of the Zariski topology (i.e. any open subset is a union of principal open subsets).

If  $h \in K[M]$  is not a zero divisor then the elements of  $K[M][1/h] \subset QK[M]$  can be naturally considered as functions on  $M_h$  since for  $x \in M_h$  the homomorphism (4) uniquely extends to a homomorphism  $K[M][1/h] \rightarrow K$ . On the other hand, for  $x \notin M_h$  such an extension is clearly impossible. This means that  $M_h$  can be considered as an affine variety with the polynomial algebra

$$K[M_h] = K[M] \left[ \frac{1}{h} \right].$$

If  $h$  is a zero divisor and  $M'$  is the union of irreducible components of  $M$  on which  $h$  does not vanish identically then  $M_h = M'_h$ , where  $h' = h|_{M'} \in K[M']$ . Since  $h'$  is not a zero divisor in  $K[M']$ , then  $M_h$  can be considered as an affine variety with the polynomial algebra  $K[M_h] = K[M'][1/h']$ . Keeping the above in mind, we will speak from now on about principal open subsets of affine varieties as about affine varieties.

Let  $L$  be a field extension of  $K$ .

**Problem 14.** The Zariski topology on  $\mathbb{A}^n$  coincides with the topology induced by the Zariski topology on  $\mathbb{A}^n(L)$ . The closure in  $\mathbb{A}^n(L)$  of any algebraic variety  $M \subset \mathbb{A}^n$  coincides with  $M(L)$  and  $I(M(L)) = LI(M)$ .

**4°. The Direct Product.** Let  $M$  and  $N$  be algebraic varieties in  $\mathbb{A}^n$  and  $\mathbb{A}^m$ , respectively. Then  $M \times N$  is an algebraic variety in  $\mathbb{A}^n \times \mathbb{A}^m = \mathbb{A}^{n+m}$ .

**Problem 15.** If  $M$  and  $N$  are irreducible then so is  $M \times N$ .

In order to describe the polynomial algebra on  $M \times N$  it is necessary to introduce the notion of the tensor product of algebras. The *tensor product*  $A \otimes B$  of algebras  $A$  and  $B$  is the tensor product of the vector spaces  $A$  and  $B$  with the multiplication

$$(a_1 \otimes b_1)(a_2 \otimes b_2) = a_1 a_2 \otimes b_1 b_2.$$

The maps  $\iota_A: a \mapsto a \otimes 1$  and  $\iota_B: b \mapsto 1 \otimes b$  determine natural embeddings of algebras  $A$  and  $B$  into  $A \otimes B$ .

The tensor product of algebras is characterized by the following universality condition: for any algebra  $C$  and algebra homomorphisms  $\varphi: A \rightarrow C$  and  $\psi: B \rightarrow C$  there exists a unique homomorphism  $\omega: A \otimes B \rightarrow C$  such that the diagram

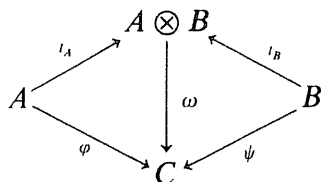

commutes. This homomorphism is defined by the formula

$$\omega(a \otimes b) = \varphi(a)\psi(b).$$

When  $\omega$  is an isomorphism, we say that  $C$  is the tensor product of  $A$  and  $B$  with respect to homomorphisms  $\varphi$  and  $\psi$ . If it is clear which homomorphisms  $\varphi$  and  $\psi$  we have in mind, we write  $C = A \otimes B$ . For example

$$K[X_1, \dots, X_n, Y_1, \dots, Y_m] = K[X_1, \dots, X_n] \otimes K[Y_1, \dots, Y_m].$$

Let  $M \subset \mathbb{A}^n$  and  $N \subset \mathbb{A}^m$  be algebraic varieties. Put  $\pi_M$  and  $\pi_N$  for projections of  $M \times N$  onto  $M$  and  $N$ , respectively.

**Problem 16.**  $K[M \times N] = K[M] \otimes K[N]$  with respect to homomorphisms  $\pi_M^*$  and  $\pi_N^*$ . The ideal  $I(M \times N)$  of the algebra  $K[X_1, \dots, X_n, Y_1, \dots, Y_m]$  is generated by the ideals  $I(M)$  and  $I(N)$  of the algebras  $K[X_1, \dots, X_n]$  and  $K[Y_1, \dots, Y_m]$  naturally embedded into  $K[X_1, \dots, X_n, Y_1, \dots, Y_m]$ .

In the sequel we will identify the algebras  $K[M \times N]$  and  $K[M] \otimes K[N]$  having in mind the isomorphism constructed in Problem 16. Under such an identification an element  $f \otimes g \in K[M] \otimes K[N]$  is presented as the function on  $M \times N$  defined by the formula

$$(f \otimes g)(x, y) = f(x)g(y).$$

An important corollary of Problem 16: The polynomial algebra on  $M \times N$  is defined by polynomial algebras on  $M$  and  $N$ , hence does not depend on embeddings of  $M$  and  $N$  into affine spaces. This enables us to define the *direct product of abstract affine varieties*  $M$  and  $N$  as the affine variety  $M \times N$  whose model is the direct product of any models of  $M$  and  $N$ .

It also follows from Problem 16 that  $(M \times N)(L) = M(L) \times N(L)$  for any field extension  $L$  of  $K$ .

**5°. Homomorphism Extension Theorems.** From here and till the end of the chapter (§§ 3.4–3.7 excluded) we will assume that  $K$  is algebraically closed.

Suppose  $A$  is a subalgebra of  $B$ . For any subset  $U \subset B$  put  $A[U]$  (or  $A[u_1, \dots]$  if  $U = \{u_1, \dots\}$ ) for the subalgebra in  $B$  generated by the set  $U$  over  $A$ , i.e. for

the collection of all elements of  $B$  presentable as polynomials in elements of  $U$  with coefficients in  $A$ . If  $A[U] = B$  we will say that  $U$  is a *system of generators of the algebra  $B$  over  $A$*  (do not confuse with the notion of generators of an ideal!) The algebra  $B$  is called *finitely generated over  $A$*  if it has a finite number of generators over  $A$ . Clearly, if  $B$  is finitely generated over  $K$  then so it is over  $A$ .

Algebras finitely generated over  $K$  will be simply called *finitely generated*.

Suppose  $B$  is without zero divisors. An element  $b \in B$  is called *algebraic over  $A$*  if there is a nonzero polynomial  $f \in A[X]$  such that  $f(b) = 0$ ; otherwise  $b$  is called *transcendental (over  $A$ )*. If  $b$  is transcendental over  $A$ , then  $A[b] \cong A[X]$ . An algebra  $B$  is called an *algebraic extension of  $A$*  if any of its elements is algebraic over  $A$ . It is convenient to introduce the quotient field  $QB$  into which the algebra  $B$  and the field  $QA$  are isomorphically embedded.

**Problem 17.** An element  $b \in B$  is algebraic over  $A$  if and only if  $QA[b]$  is a finite-dimensional vector space over  $QA$ .

**Problem 18.** If  $B = A[b_1, \dots, b_n]$ , where  $b_1, \dots, b_n$  are algebraic over  $A$ , then  $B$  is an algebraic extension of  $A$ .

**Theorem 3.** Suppose  $B$  is an algebra without zero divisors finitely generated over its subalgebra  $A$ . Then for any nonzero element  $b \in B$  there exists a nonzero element  $a \in A$  such that any homomorphism  $\varphi: A \rightarrow \mathbb{C}$  that does not annihilate  $a$  extends to a homomorphism  $\psi: B \rightarrow \mathbb{C}$  which does not annihilate  $b$ .

**Problem 19.** Prove Theorem 3 when  $B = A[u]$ , where  $u$  is transcendental over  $A$ .

**Problem 20.** Prove Theorem 3 when  $B = A[u]$ , where  $u$  is algebraic over  $A$ .

**Problem 21.** Prove Theorem 3.

**Corollary.** If  $B$  is a finitely generated algebra without zero divisors then for any nonzero  $b \in B$  there exists a homomorphism  $\psi: B \rightarrow \mathbb{C}$  which does not annihilate  $b$ .

**Theorem 4.** Let  $\text{char } K = 0$ . Suppose  $B$  is a finitely generated algebra without zero divisors and  $A$  is its finitely generated subalgebra. If there exists a nonzero element  $b \in B$  such that any homomorphism  $A \rightarrow \mathbb{C}$  has no more than one extension to a homomorphism  $B \rightarrow \mathbb{C}$  which does not annihilate  $b$ , then  $B \subset QA$ .

**Problem 22.** Prove Theorem 4.

**6°. The Image of a Dominant Morphism.** A morphism  $f: M \rightarrow N$  of irreducible affine varieties is called *dominant* if  $\overline{f(M)} = N$ .

**Problem 23.** A morphism  $f$  is dominant if and only if the corresponding algebra homomorphism  $f^*: K[N] \rightarrow K[M]$  is injective.

A dominant morphism may be not surjective. For instance let  $M = \{(X_1, X_2) \in \mathbb{A}^2: X_1 X_2 = 1\}$ ,  $N = \mathbb{A}^1$  and  $f: (X_1, X_2) \mapsto (X_1)$ ; then  $f(M) = \mathbb{A}^1 \setminus \{0\}$ . Nevertheless, the image of a dominant morphism is sufficiently large as it is shown by the following theorem.

A sub:  
nonempt  
finite nu

**Theore**  
The imag

*Proof.*  
subset o:  
geometri  
identify t

Indeed  
of  $K[M]$   
 $K[N]$  of  
 $g \in K[M]$   
 $K[N] \rightarrow$   
that does

7°. Hi  
 $A/I$  does  
 $b \in I$ . Fo  
and only  
Clearl  
elements

**Theore**  
prime ide  
*Proof*

**Proble**  
 $RA$ .

In par  
algebra  
nilpoten  
A refo

**Theore**  
on zero  
 $K[X_1, \dots]$   
Apply

**Coroll**

**Proble**  
point of

**Proble**  
of non-  
 $K[M] -$

A subset of an irreducible topological space is called *épais* if it contains a nonempty open subset. Clearly, any *épais* subset is dense. The intersection of a finite number of *épais* subsets is *épais* itself.

**Theorem 5.** *Let  $f: M \rightarrow N$  be a dominant morphism of irreducible affine varieties. The image  $f(M_0)$  of any *épais* subset  $M_0 \subset M$  is an *épais* subset in  $N$ .*

*Proof.* It suffices to prove that the image of any nonempty principal open subset of  $M$  contains a nonempty principal open subset of  $N$ . This is the geometric equivalent of Theorem 3 applied to  $A = K[N]$  and  $B = K[M]$  if we identify the elements of  $K[N]$  with their images under  $f^*$ .

Indeed, the points of  $M$  and  $N$  can be considered as homomorphisms into  $K$  of  $K[M]$  and  $K[N]$  respectively. Then  $f$  can be viewed as a restriction onto  $K[N]$  of the homomorphisms  $K[M] \rightarrow K$ . By Theorem 3 for any nonzero  $g \in K[M]$  there exists a nonzero  $h \in K[N]$  such that any homomorphism  $K[N] \rightarrow K$  that does not annihilate  $h$  extends to a homomorphism  $K[M] \rightarrow K$  that does not annihilate  $g$ ; but this means that  $f(M_g) \supset N_h$ .  $\square$

**7°. Hilbert's Nullstellensatz.** An ideal  $I$  of  $A$  different from  $A$  is *prime* if  $A/I$  does not have zero divisors. This means that if  $ab \in I$  then either  $a \in I$  or  $b \in I$ . For example, in  $K[X]$ , the ideal generated by a polynomial  $f$  is prime if and only if  $f$  is a first degree polynomial.

Clearly, a prime ideal contains all nilpotent elements. The set of all nilpotent elements of  $A$  is an ideal called the *radical* of  $A$  and is denoted by  $RA$ .

**Theorem 6.** *The radical of an algebra  $A$  coincides with the intersection of all the prime ideals of  $A$ .*

*Proof* see e.g. in [8], [53].

**Problem 24.** The kernel of the homomorphism  $\rho$  defined in Problem 4 equals  $RA$ .

In particular, a finitely generated algebra  $A$  coincides with the polynomial algebra on the affine variety that  $A$  defines if and only if  $A$  has no nonzero nilpotent elements.

A reformulation of Problem 24 is

**Theorem 7** (Hilbert's Nullstellensatz which in German means 'theorem on zeroes'). *Suppose  $M = M(I) \subset \mathbb{A}^n$  is the variety defined by an ideal  $I \subset K[X_1, \dots, X_n]$ . For any  $f \in I(M)$  there exists  $k$  such that  $f^k \in I$ .*

Applying this theorem to  $f = 1$  we obtain

**Corollary.** *If  $M(I) = \emptyset$  then  $I = K[X_1, \dots, X_n]$ .*

**Problem 25.** Let  $M$  be an affine variety and  $I$  an ideal of  $K[M]$ . If there is no point of  $M$  at which all the polynomials of  $I$  vanish, then  $I = K[M]$ .

**Problem 26.** Suppose an affine variety  $M$  is presented in the form of a union of non-intersecting closed subsets  $M_1, \dots, M_q$ . Then the homomorphism  $K[M] \rightarrow K[M_1] \times \dots \times K[M_q]$ ,  $f \mapsto (f|_{M_1}, \dots, f|_{M_q})$  is an isomorphism.

In other words, any function on  $M$  whose restrictions to  $M_1, \dots, M_q$  are polynomials is a polynomial itself.

**8°. Rational Functions.** Let  $M$  be an affine variety. The algebra  $QK[M]$  is called the *algebra of rational functions on  $M$*  and is denoted by  $K(M)$ . Problem 11 shows that if  $M$  is irreducible then  $K(M)$  is a field. In particular,  $K(\mathbb{A}^n) = K(X_1, \dots, X_n)$  is the field of rational functions in  $X_1, \dots, X_n$ .

The elements of  $K(M)$  are called *rational functions on  $M$* . A function  $f \in K(M)$  is *defined at a point  $x \in M$*  if  $f$  can be presented in the form of a ratio  $g/h$ , where  $g, h \in K[M]$ , such that  $h(x) \neq 0$ . In this case the element  $g(x)/h(x)$  is called the *value of  $f$  at  $x$*  and is denoted by  $f(x)$ . The value does not depend on the choice of representation of  $f$  in the form of such a ratio.

The set of all points  $x \in M$  where a rational function  $f \in K(M)$  is defined is called the *domain of  $f$* . This set will be denoted by  $D_f$ .

The following properties of rational functions are obvious:

(R1) the domain  $D_f$  of  $f \in K(M)$  is a dense open subset in  $M$ ;

(R2) the map  $f: D_f \rightarrow K$  is continuous ( $K$  is considered here as  $\mathbb{A}^1$  with the Zariski topology);

(R3)  $f$  as an element of  $K(M)$ , is uniquely determined by its restriction to any dense open subset;

(R4) the operations on the elements of  $K(M)$  coincide with the usual operations on functions where these functions are defined.

Let  $f$  be a rational function on  $M$ . The denominators of all possible presentations of  $f$  in the form of a ratio of two polynomials are precisely the nondivisors of zero contained in the ideal

$$I_f = \{h \in K[M]: fh \in K[M]\}$$

**Problem 27.** The ideal  $I_f$  is generated by the nondivisors of zero contained in it. The domain of  $f$  is the complement of the variety of zeros of this ideal.

**Problem 28.** Any rational function defined at all points of  $M$  is a polynomial, i.e. belongs to  $K[M]$ .

**Problems 29.** Any rational function defined at all points of a principal open subset  $M_h$ , where  $h \in K[M]$  is a nondivisor of zero, can be presented in the form  $g/h^k$  ( $g \in K[M]$ ), i.e. belongs to  $K[M][1/h] \subset K(M)$ .

Let  $M'$  be the union of some irreducible components of  $M$ . Since the restriction homomorphism  $K[M] \rightarrow K[M']$  maps the nondivisors of zero into nondivisors of zero, it extends to a homomorphism  $K(M) \rightarrow K(M')$ . The image of a rational function  $f \in K(M)$  under this homomorphism is called its *restriction to  $M'$*  and is denoted by  $f|_{M'}$ .

**Problem 30.** If  $f$  is defined at  $x \in M'$  then so is  $f|_{M'}$  and  $f|_{M'}(x) = f(x)$ .

Let  $M''$  be the union of the irreducible components of  $M$  which do not occur in  $M'$ .

**Problem 31.** If  $f|_{M'}$  is defined at  $x \in M' \setminus M''$  then so is  $f$ .

**Problem 32.** Let  $M = M_1 \cup \cdots \cup M_q$  be the decomposition of  $M$  into irreducible components. Then the homomorphism

$$K(M) \rightarrow K(M_1) \times \cdots \times K(M_q), f \mapsto (f|_{M_1}, \dots, f|_{M_q})$$

is an isomorphism.

**9°. Rational Maps.** A *rational map* of an affine variety  $M$  into  $\mathbb{A}^m$  is a map of the form

$$f: x \mapsto (f_1(x), \dots, f_m(x)), \quad (5)$$

where  $f_1, \dots, f_m \in K(M)$ . The map  $f$  is considered as *defined at a point*  $x \in M$  if all the functions  $f_1, \dots, f_m$  are defined at this point.

**Problem 33.** The domain of a rational map is an open dense subset of  $M$ . A rational map is continuous on its domain.

Now let  $N$  be another affine variety. Considering  $N$  as embedded into  $\mathbb{A}^m$  define a *rational map*  $f: M \rightarrow N$  as a rational map  $f: M \rightarrow \mathbb{A}^m$  such that  $f(M) \subset N$ .

**Problem 34.** The notion of a rational map into a variety  $N$  does not depend on the embedding of  $N$  into an affine space.

Under the inversely directed homomorphism of the algebras of functions defined by formula (3) the coordinate functions are mapped into the functions  $f_i$  while the polynomials on  $N$  are mapped into the rational functions on  $M$ . Thus, a rational map  $f: M \rightarrow N$  induces a homomorphism  $f^*: K[N] \rightarrow K(M)$ . Formula (3) means here that if  $f$  is defined at  $x$  then so is  $f^*g$  and (3) holds.

**Problem 35.** For any homomorphism  $\varphi: K[N] \rightarrow K(M)$  there is a unique rational map  $f: M \rightarrow N$  such that  $f^* = \varphi$ .

Thus, to define a rational map of a variety  $M$  into a variety  $N$  is the same as to define an algebra homomorphism  $K[N] \rightarrow K(M)$ . If the image of  $K[N]$  under this homomorphism is contained in  $K[M]$ , then the corresponding rational map is a morphism.

Suppose that a rational map  $f: M \rightarrow N$  is defined by formula (5) and  $h \in K[M]$  is a polynomial which is not a zero divisor in  $K[M]$  such that  $hf_i \in K[M]$  for  $i = 1, \dots, m$  (e.g. we may take for  $h$  the product of denominators of some presentations of the functions  $f_i$  in the form of a ratio of polynomials). Then  $f_i \in K[M][1/h]$ , i.e. the functions  $f_i$ , where  $i = 1, \dots, m$ , are polynomials on the affine variety  $M_h$  (see Problem 30). Thus the restriction of a rational map to a suitable dense principal open subset is a morphism.

A rational map  $f: M \rightarrow N$  of irreducible affine varieties is called *dominant* if  $\overline{f(M)} = N$ .

**Problem 36.** A rational map  $f$  is dominant if and only if  $f^*$  is injective. If  $f$  is dominant then  $f^*$  extends to an algebra homomorphism  $K(N) \rightarrow K(M)$  (also denoted by  $f^*$ ).

Formula (3) is valid for any rational function  $g$  defined at the point  $f(x)$ .

The superposition of a dominant rational map  $f: M \rightarrow N$  and a rational map  $g: N \rightarrow P$  can be defined as a rational map  $gf: M \rightarrow P$  such that  $(gf)^* = f^*g^*$ .

Clearly, if  $f$  is defined at  $x \in M$  and  $g$  is defined at  $f(x) \in N$  then  $gf$  is defined at  $x$  and  $(gf)(x) = g(f(x))$ .

Note that the map  $gf$  may be defined not only at points satisfying the above condition. For example, let  $M = N = P = A^1$  and  $f = g: (X) \mapsto (1/X)$ ; then  $gf$  is the identity morphism which is defined everywhere, whereas  $f$  is not defined at 0.

### 10°. Factorization of a Morphism

**Theorem 8.** Let  $\text{char } K = 0$ , let  $M, N, P$  be irreducible affine varieties and let  $f: M \rightarrow N, h: M \rightarrow P$  be dominant morphisms. If  $f(x') = f(x'')$  implies  $h(x') = h(x'')$  for any points  $x', x''$  of an épais subset  $M_0 \subset M$ , then there exists a rational map  $g: N \rightarrow P$  such that  $h = gf$ .

The situation is illustrated by the following commutative diagram

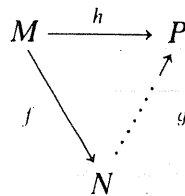

*Proof.* First consider a particular case, when  $P = M$  and  $h = id$ . In this case the condition of the theorem means that  $f$  is one-to-one on  $M_0$ . Let  $M_b$ , where  $b \in K[M], b \neq 0$ , be a principal open subset contained in  $M_0$ .

The same arguments as in the proof of Theorem 7 yield the following algebraic formulation of the bijectiveness of  $f$  on  $M_b$ : any homomorphism of  $f^*K[N] \cong K[N]$  into  $K$  extends in no more than one way to a homomorphism  $K[M] \rightarrow K$  that does not annihilate  $b$ . By Theorem 4 this implies that  $K[M] \subset f^*K(N)$ . In other words, there is a homomorphism  $\varphi: K[M] \rightarrow K(N)$  such that  $f^*\varphi = id$ . The rational map  $g: N \rightarrow M$  defined by this homomorphism is the required inverse of  $f$ .

In general case, consider an auxiliary rational map

$$l: M \rightarrow N \times P, x \mapsto (f(x), h(x))$$

The closure of its image will be denoted by  $L$ . Furthermore, let  $p_1$  and  $p_2$  be the restrictions onto  $L$  of the projections of the product  $N \times P$  onto the first and second factor, respectively. The conditions of the theorem imply that  $p_1$  is a bijection onto the épais subset  $l(M_0) \subset L$ . By the above there exists a rational map  $k: N \rightarrow L$  inverse to  $p_1$ . The map  $g = p_2k$  is the one sought for. Proof is illustrated by the following commuting diagram:

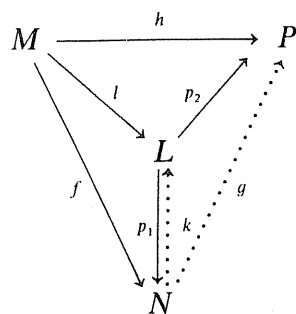

Note that the assumption  $\text{char } K = 0$  is essential. Indeed, suppose that  $\text{char } K = p > 0$ . Then the morphism  $f: \mathbb{A}^1 \rightarrow \mathbb{A}^1, (X) \mapsto (X^p)$  is a bijection but the inverse map is not rational.

### Exercises

The ground field  $K$  is assumed to be algebraically closed.

- 1) Let  $M$  and  $N$  be algebraic varieties in  $\mathbb{A}^n$  and  $N \subset M$ . Then  $K[N]$  is a quotient algebra of  $K[M]$ .
- 2) What is the Zariski topology in  $\mathbb{A}^1$ ?
- 3) The Zariski topology in  $\mathbb{A}^n$  is not the Hausdorff one.
- 4) Any open covering of a noetherian topological space has a finite subcovering.
- 5) Suppose  $f = p_1^{k_1} \dots p_s^{k_s}$  is a decomposition of a polynomial  $f \in \mathbb{C}[X_1, \dots, X_n]$  into irreducible factors. Then  $M(f) = \bigcup M(p_i)$  is the decomposition of the variety  $M(f)$  into irreducible components.
- 6) Give an example of two nonisomorphic algebras that define the same algebraic variety in  $\mathbb{A}^n$ .
- 7) An affine algebraic variety defined by a finite-dimensional algebra consists of a finite number of points.
- 8) A finitely generated algebra which is a field coincides with  $K$ .
- 9) Suppose  $A$  is a finitely generated algebra,  $I$  its maximal ideal. Then  $A/I \cong K$ .
- 10) There is a one-to-one correspondence between the points of an affine algebraic variety  $M$  defined by a finitely generated algebra  $A$  and the maximal ideals of this algebra: to a point  $x \in M$  the kernel of the homomorphism  $\varphi_x: A \rightarrow K$  corresponds.
- 11) If two finitely generated algebras do not have zero divisors (or nilpotent elements) then so does their tensor product. (Prove geometrically.)
- 12) The radical of a finitely generated algebra coincides with the intersection of all its maximal ideals.  
An ideal  $I$  of an algebra  $A$  is called a *radical ideal* if  $f^m \in I$  implies  $f \in I$ .
- 13) Any radical ideal of a finitely generated algebra is the intersection of a finite number of prime ideals.
- 14) Find the domain of the rational function  $x_1/x_3$  on the algebraic variety in  $\mathbb{A}^4$  defined by the equation  $X_1 X_4 = X_2 X_3$ .
- 15) Find the image of the variety  $M = \mathbb{A}^1$  under the rational map  $(X) \mapsto ((1 - X^2)/(1 + X^2), 2X/(1 + X^2))$ .

- 16) Suppose  $M = \mathbb{A}^1$ , and  $f: (X) \mapsto (X^2, X^3)$ . There is an inverse rational map  $f^{-1}: f(M) \rightarrow \mathbb{A}^1$  but it is not defined at  $f(0)$ .
- 17) Suppose  $f_1, \dots, f_k, g$  are rational functions on  $\mathbb{A}^n$ . If  $g$  is constant on the level surfaces of the family  $\{f_1, \dots, f_k\}$ , then it may be presented in the form of a rational function in  $f_1, \dots, f_k$ .
- An *elementary algebraic predicate* in variables  $x \in \mathbb{A}^n, y \in \mathbb{A}^m, z \in \mathbb{A}^p, \dots$  is a predicate of the form " $F(x, y, z, \dots) = 0$ ", where  $F$  is a polynomial in  $n + m + p + \dots$  variables. Furthermore an *algebraic predicate* is any predicate obtained from elementary ones within the framework of the logic of predicates, i.e. by making use of (a finite number of) conjunctions, disjunctions and negations and also quantifiers of existence and generality.
- A set  $M \subset \mathbb{A}^m \times \mathbb{A}^n \times \mathbb{A}^p \times \dots$  is *constructible* if there exists a predicate  $P$  containing free variables  $x \in \mathbb{A}^n, y \in \mathbb{A}^m, z \in \mathbb{A}^p, \dots$  (and containing no other free variables), such that  $(a, b, c, \dots) \in M$  if and only if  $P(a, b, c, \dots) = 0$ .
- 18) An irreducible component of a constructible set is constructible itself.
- 19) The image of an irreducible constructible set under a rational map into  $\mathbb{A}^q$  is a constructible set in  $\mathbb{A}^q$ .
- 20) Any constructible set can be presented as a finite union of sets of the form  $F \setminus G$ , where  $F$  and  $G$  are closed sets.
- 21) An irreducible constructible set is *épais* in its closure.

### Hints to Problems

5. The desired morphism is of the form  $x \mapsto (f_1(x), \dots, f_m(x))$ , where  $f_i = \varphi(y_i)$ , where  $y_1, \dots, y_m$  are the restrictions on  $\mathcal{N}$  of coordinates in  $\mathbb{A}^m$ .
6.  $M(S_1) \cup M(S_2) = M(S)$ , where  $S = \{f_1 f_2: f_1 \in S_1 \text{ and } f_2 \in S_2\}$ .
8. This is a geometric equivalent of Theorem 1.
10. The topological spaces that are not representable as unions of finite numbers of closed irreducible subsets will be called bad spaces. Suppose  $M$  is bad. Then, in particular,  $M$  can not be irreducible, therefore  $M = M_1 \cup M_2$ , where  $M_1, M_2$  are proper closed subsets and at least one of  $M_1, M_2$  is bad. Suppose  $M_1$  is bad. Then  $M_1 = M_{11} \cup M_{12}$ , where  $M_{11}, M_{12}$  are proper closed subsets and at least one of  $M_{11}, M_{12}$  is bad. Suppose this is  $M_{11}$ . Continuing the process, we obtain an infinite descending chain  $M \supset M_1 \supset M_{11} \supset \dots$  of closed subsets of  $M$ . If  $M$  is noetherian, this is impossible.
- Suppose  $M = \bigcup_{1 \leq i \leq k} M_i$ , where  $M_i$  is a closed irreducible subset such that  $M_i \not\subset M_j$  for  $i \neq j$ . Then  $M_1, \dots, M_k$  are all the maximal irreducible subsets of  $M$ , and therefore the  $M_i$  are uniquely defined.
11. Suppose there are nonzero elements  $f_1, f_2 \in K[M]$  such that  $f_1 f_2 = 0$ . Then  $M = M_1 \cup M_2$ , where  $M_k = \{x \in M: f_k(x) = 0\}$  so that  $M_1 \neq M$  and  $M_2 \neq M$ . Thus, if  $K[M]$  has zero divisors then  $M$  is reducible, and each zero divisor vanishes on an irreducible component of  $M$ .
14. Let  $\{u_\alpha\}$  be a basis of  $L$  as of a vector space over  $K$ . Any polynomial  $f \in L[X_1, \dots, X_n]$  is representable in the form  $f = \sum_\alpha u_\alpha f_\alpha$ , where  $f_\alpha \in K[X_1, \dots, X_n]$  and for a point  $x \in \mathbb{A}^n$  the condition  $f(x) = 0$  is equivalent to the conjunction of the conditions  $f_\alpha(x) = 0$ . Therefore the intersection of any

closed subset of  $\mathbb{A}^n(L)$  with  $\mathbb{A}^n$  is closed in  $\mathbb{A}^n$ . Proof of the remaining statements is similar.

15. Suppose  $M \times N = P_1 \cup P_2$ , where  $P_1$  and  $P_2$  are closed subsets. For any  $x \in M$  consider the closed sets

$$P_k(x) = \{y \in N : (x, y) \in P_k\} \subset N \quad \text{for } k = 1, 2.$$

Since  $P_1(x) \cup P_2(x) = N$ , one of the sets  $P_1(x)$  or  $P_2(x)$  coincides with  $N$ . Now consider the closed sets  $M_k = \{x \in M : (x, y) \in P_k \text{ for any } y \in N\} \subset M$ , where  $k = 1, 2$ . By the previous results  $M = M_1 \cup M_2$ . Hence,  $M$  coincides either with  $M_1$  or with  $M_2$ . If  $M = M_k$ , then  $M \times N = P_k$ , therefore  $M \times N = P_1$  or  $P_2$ .

16. Let  $\{f_1, f_2, \dots\}$  be a basis of  $K[M]$ . The homomorphism  $\omega: K[M] \otimes K[N] \rightarrow K[M \times N]$  defined by  $\pi_M^*$  and  $\pi_N^*$  assigns to  $u = \sum_i f_i \otimes g_i$  ( $g_i \in K[N]$ ) the function  $h(x, y) = \sum_i f_i(x)g_i(y)$  ( $x \in M, y \in N$ ). Therefore  $g_i(y) = 0$  for any  $i$  and  $y \in N$ , but then  $u = 0$ . This proves the injectivity of  $\omega$ . Its surjectivity is clear. The second statement of the problem follows from the first one.
19. For any  $f \in A[X]$  put  $f^\varphi$  for a polynomial of  $K[X]$  which is obtained from  $f$  by applying the homomorphism  $\varphi$  coefficient-wise. Let  $b = g(u)$  and  $\alpha \in K$  be any number which is not a root of  $g^\varphi$ . Define the homomorphism  $\psi$  setting  $\psi(f(u)) = f^\varphi(\alpha)$ . In this case  $g^\varphi \neq 0$  is the only restriction on  $\varphi$ . This condition is verified if we take for  $a$  any nonzero coefficient of  $g$ .
20. Let  $p \in A[X]$  be the minimal polynomial of  $u$ . Denote by  $a_1$  the highest degree coefficient of  $p$ . If  $q \in A[X]$  is such that  $q(u) = 0$ , then  $q$  is divisible by  $p$  in  $QA[X]$  and there exists  $k$  such that  $a_1^k q$  is divisible by  $p$  in  $A[X]$ .

Therefore, if  $\varphi(a_1) \neq 0$  and  $\alpha \in K$  is a root of  $p^\varphi$ , then the homomorphism  $\psi: B \rightarrow K$  that coincides with  $\varphi$  on  $A$  is well-defined by the formula  $\psi(f(u)) = f^\varphi(\alpha)$ .

Now let us make  $\psi(b) \neq 0$ . By Problem 18  $b$  is algebraic over  $A$ . Let  $h \in A[X]$  be a nonzero polynomial such that  $h(b) = 0$ . We may assume that the constant term  $a_2$  of  $h$  is nonzero (otherwise we divide  $h$  by  $X$ ). If  $\varphi(b) = \beta$ , then  $h^\varphi(\beta) = 0$ . Let  $\varphi(a_2) \neq 0$ . Then  $\beta$  is a root of a polynomial with a nonzero constant term and therefore  $\beta \neq 0$ . Thus we may put  $a = a_1 a_2$ .

21. The induction in the number of generators of the algebra  $B$  over  $A$  reduces the proof to the cases considered in Problems 19 and 20.
22. The induction in the number of generators of the algebra  $B$  over  $A$  enables us to reduce the proof to the case  $B = A[u]$ . In this case we are under the conditions of Problems 19 or 20. Let  $a \in A$  be a nonzero element constructed while solving the corresponding problem. By Corollary of Theorem 3 there is a homomorphism  $\varphi: A \rightarrow K$  that does not annihilate  $a$ . The solutions of Problems 19 and 20 show that the homomorphism  $\varphi$  uniquely extends to a homomorphism  $\psi: B \rightarrow K$  only when  $u$  is algebraic over  $A$  and  $p^\varphi$  has a unique root, i.e.  $p^\varphi = c(X - \alpha)^k$ , where  $c \in K$  and  $c \neq 0$ .

Let us show that if  $m = \deg p > 1$ , then  $\varphi$  can be chosen so that the polynomial  $p^\varphi$  is not of this form. Since  $p$  is irreducible over  $QA$ , then, in particular,  $p$  is not proportional to any power of a linear binomial. Let

$$p = p_0 + p_1 X + \cdots + p_m X^m, \quad \text{where } p_i \in A, p_m \neq 0.$$

There exists  $i \leq m - 2$  such that  $p_i \neq p_m \binom{m}{i} (p_{m-1}/mp_m)^{m-i}$ , i.e.  $m^{m-i} p_m^{m-i-1} p_i \neq \binom{m}{i} p_{m-1}^{m-i}$ , otherwise  $p = p_m (X + (p_{m-1}/mp_m))^m$ . If we require an extra condition:  $\varphi(m^{m-i} p_m^{m-i-1} p_i - \binom{m}{i} p_{m-1}^{m-i}) \neq 0$ , then  $p^\varphi$  also is not proportional to any degree of a linear binomial.

Thus,  $\deg p = 1$ . But this means exactly that  $u \in QA$  and hence  $B \subset QA$ .

24. First show that the kernel of  $\rho$  coincides with the intersection of the kernels of all the homomorphisms  $A \rightarrow K$ . Further, apply Theorem 5 and Corollary of Theorem 3.
25. Consider an embedding  $M \rightarrow \mathbb{A}^n$  and apply Theorem 7 to the preimage of the ideal  $I$  with respect to the restriction homomorphism  $K[X_1, \dots, X_n] \rightarrow K[M]$  and to  $f = 1$ .
26. The proof reduces to the case  $q = 2$ . In this case Problem 25 implies that  $I_M(M_1) + I_M(M_2) = K[M]$ . This means that the considered map is surjective. Its injectivity is obvious.
27. Let  $M = M_1 \cup \cdots \cup M_q$  be the decomposition of  $M$  into irreducible components. By Problem 11 the set of zero divisors of  $K[M]$  is the union of the ideals  $I_M(M_s)$ ,  $s = 1, \dots, q$ . Since  $I_f$  contains at least one nondivisor of zero, then  $I_f \cap I_M(M_s)$  is a proper subspace of  $I_f$  for any  $s$ . If all the nondivisors of zero contained in  $I_f$  had belonged to some of its proper subspaces, then  $I_f$  would have been a union of a finite number of proper subspaces which is impossible.
28. Let  $f$  be such a function. The conditions of the problem imply that the variety of zeros of  $I_f$  is empty. By Problem 25 this implies that  $I_f \ni 1$ , i.e.  $f$  is presentable in the form  $f = g/1$ , where  $g \in K[M]$ , as required.
29. Is solved like Problem 28 but with the help of the Hilbert's Nullstellensatz itself.
31. Passing to an appropriate dense principal open subset reduce to the case when  $M' \cap M'' = \emptyset$  and use Problem 26.
32. Passing to an appropriate dense principal open subset reduce to the case when irreducible components of  $M$  do not intersect and use Problem 26.
35. Let  $N$  be embedded in the affine space  $\mathbb{A}^m$  with coordinates  $Y_1, \dots, Y_m$ . Then the required map is of the form  $x \mapsto (f_1(x), \dots, f_m(x))$ , where  $f_i = \varphi(y_i)$ ,  $y_i = Y_i|_N$ .

## §2. Projective and Quasiprojective Varieties

**1°. Graded Algebras.** Before we start to define projective varieties recall certain elementary facts on graded vector spaces and algebras.

A vector space  $V$  is *graded* if there are distinguished subspaces  $V_k$  ( $k \in \mathbb{Z}$ ) in it called *grading subspaces* such that  $V = \bigoplus_k V_k$ . The nonzero elements of  $V_k$  are then called *homogeneous* elements of degree  $k$ . By definition any nonzero element is uniquely presentable as the sum of homogeneous elements called its *homogeneous components*. A subspace  $U \subset V$  is called *homogeneous* if together with each of its elements it contains all its homogeneous components. This is equivalent to the fact that  $U = \bigoplus_k U_k$ , where  $U_k \subset V_k$ . If  $U$  is a homogeneous subspace then the quotient space  $V/U$  inherits the grading such that  $(V/U)_k = V_k/U_k$ .

A grading is called *nonnegative* if  $V_k = 0$  for  $k < 0$ . In this chapter we will only consider nonnegative gradings.

An algebra  $A$  is called *graded* if it is graded by subspaces  $A_k$  ( $k \in \mathbb{Z}$ ) as a vector space and  $A_k A_l \subset A_{k+l}$  for any  $k, l \in \mathbb{Z}$ . If  $I$  is a homogeneous ideal of a graded algebra  $A$  then  $A/I$  is also a graded algebra.

A polynomial algebra possesses a standard nonnegative grading: the homogeneous elements of degree  $k$  are just the forms (homogeneous polynomials) of degree  $k$ . Notice, that in this case all the grading subspaces are finite dimensional (though the algebra itself is infinite dimensional).

**Problem 1.** The radical of a graded algebra is a homogeneous ideal.

**Problem 2.** If there are no homogeneous zero divisors in a graded algebra  $A$  i.e.  $pq = 0$  for  $p \in A_k, q \in A_l$  implies either  $p = 0$  or  $q = 0$ , then there are no zero divisors in  $A$  at all.

**2°. Embedded Projective Algebraic Varieties.** Let  $\mathbb{P}^n$  be an  $n$ -dimensional projective space over  $K$  and  $U_0, U_1, \dots, U_n$  homogeneous coordinates in  $\mathbb{P}^n$ . Since homogeneous coordinates of a point are only defined up to a simultaneous multiplication by a nonzero element of  $K$ , it is impossible to speak about the value of a polynomial  $p \in K[U_0, U_1, \dots, U_n]$  at a point  $x \in \mathbb{P}^n$ . But if  $p$  is a form (i.e. a homogeneous polynomial) the equality  $p(x) = 0$  is meaningful. If  $p$  and  $q$  are forms of the same degree and  $q(x) \neq 0$ , then the ratio  $p(x)/q(x)$  is well defined.

An algebraic variety in  $\mathbb{P}^n$  or an embedded *projective algebraic variety* is a subset in  $\mathbb{P}^n$  singled out by the system of equations

$$p(U_0, U_1, \dots, U_n) = 0 \quad (p \in S) \quad (1)$$

where  $S$  is a set of forms. The variety defined by system (1) will be denoted by  $M^{pr}(S)$ .

**Problems 3.** Any homogeneous ideal of  $K[U_0, U_1, \dots, U_n]$  possesses a finite system of homogeneous generators.

Let  $M$  be an algebraic variety in  $\mathbb{P}^n$ . Consider a subspace of  $K[U_0, U_1, \dots, U_n]$  generated by all forms that vanish on  $M$ . This subspace is a homogeneous ideal. Denote it by  $I^{pr}(M)$ . If  $S$  is a system of its homogeneous generators, then  $M = M^{pr}(S)$ . Therefore Problem 3 implies that any algebraic variety in  $\mathbb{P}^n$  can be defined by a finite number of homogeneous equations.

Call the algebraic varieties in  $\mathbb{P}^n$  its closed subsets. This introduces a topology in  $\mathbb{P}^n$  (cf. Problem 1.6) called the *Zariski topology*.

**Problem 4.** The space  $\mathbb{P}^n$  endowed with the Zariski topology is an irreducible noetherian topological space (see 1.3).

Now define rational functions on an algebraic variety  $M \subset \mathbb{P}^n$ . Consider the algebra

$$K[M]^{\text{pr}} = K[U_0, U_1, \dots, U_n]/I^{\text{pr}}(M).$$

Since  $I^{\text{pr}}(M)$  is a homogeneous ideal,  $K[M]^{\text{pr}}$  inherits the grading of  $K[U_0, U_1, \dots, U_n]$ .

Unlike in the affine case, the elements of  $K[M]^{\text{pr}}$  cannot be considered as functions on  $M$ . However, if  $p \in K[M]^{\text{pr}}$  is a homogeneous element then the identity  $p(x) = 0$  makes sense for  $x \in M$ ; if  $p, q \in K[M]^{\text{pr}}$  are homogeneous elements of the same degree and  $q(x) \neq 0$ , then the ratio  $p(x)/q(x)$  makes sense.

**Problem 5.**  $M$  is irreducible if and only if  $K[M]^{\text{pr}}$  has no zero divisors. More precisely, the homogeneous zero divisors of  $K[M]^{\text{pr}}$  are its homogeneous elements which vanish on an irreducible component of  $M$ .

In  $QK[M]^{\text{pr}}$ , consider the subalgebra generated by the ratios of the form  $p/q$ , where  $p, q$  are homogeneous elements of the same degree (and  $q$  is not a zero divisor). This subalgebra is denoted by  $K(M)$  and is called the *algebra of rational functions* on  $M$ . Problem 5 shows that if  $M$  is irreducible then  $K(M)$  is a field.

The elements of  $K(M)$  are called *rational functions* on  $M$ . A function  $f \in K(M)$  is considered defined at  $x \in M$  if it is presentable in the form  $p/q$ , where  $p, q \in K[M]^{\text{pr}}$  are homogeneous elements of the same degree and  $q(x) \neq 0$ . In this case the ratio  $p(x)/q(x) \in K$  (independent of the choice of such a presentation) is called the *value* of  $f$  at  $x$  and is denoted by  $f(x)$ . As in the affine case, the properties (R1)–(R4) of 1.8 hold.

Let  $f$  be a rational function on  $M$ . The denominators of all possible representations of  $f$  in the form of a ratio of two homogeneous elements (of the same degree) of  $K[M]^{\text{pr}}$  are exactly the homogeneous nondivisors of zero contained in the homogeneous ideal

$$I_f = \{h \in K[M]^{\text{pr}}: fh \in K[M]^{\text{pr}}\}.$$

**Problem 6.** The domain  $D_f$  of  $f$  is the complement of the set of zeros of  $I_f$ , i.e. of the set of points where all homogeneous elements of  $I_f$  vanish.

The following theorem demonstrates the crucial difference between projective varieties and affine ones.

**Theorem 1.** Let  $M \subset \mathbb{P}^n$  be an irreducible algebraic variety. Any rational function  $f \in K(M)$  defined at all points of  $M$  is a constant, i.e. belongs to  $K$ .

*Proof.* Consider the affine space  $\mathbb{A}^{n+1}$  with coordinates  $U_0, U_1, \dots, U_n$ . Let  $I$  be the pre-image of  $I_f$  with respect to the canonical homomorphism

$$\pi: K[U_0, U_1, \dots, U_n] \rightarrow K[M]^{\text{pr}}.$$

The absence of zeros of  $I_f$  on  $M$  means that the unique zero of  $I$  on  $\mathbb{A}^{n+1}$  is the origin. Applying Hilbert's Nullstellensatz to the ideal  $I \subset K[U_0, U_1, \dots, U_n]$  and the coordinate functions  $U_0, U_1, \dots, U_n$  we see that  $I$  contains some powers of all coordinate functions and therefore contains all homogeneous polynomials of a sufficiently high degree. Therefore  $I_f$  contains all homogeneous elements of  $K[M]^{\text{pr}}$  of a sufficiently high degree.

Let  $V$  be one of the grading subspaces of  $K[M]^{\text{pr}}$  belonging entirely to  $I_f$ . The map  $h \mapsto fh$  ( $h \in V$ ) is a linear transformation. Consider an eigenvector  $h_0$  of this transformation. We have  $fh_0 = ch_0$  ( $c \in k$ ) and since  $h_0$  is not a zero divisor ( $M$  is irreducible!), we have  $f = c$ , as required.

Developing the arguments contained in the first part of this proof we may assign to every algebraic variety  $M \subset \mathbb{P}^n$  an algebraic variety  $\hat{M} \subset \mathbb{A}^{n+1}$ , "the cone over  $M$ ", defined by the same equations as  $M$  (but in which  $U_0, U_1, \dots, U_n$  are considered as coordinates in  $\mathbb{A}^{n+1}$ ). Then  $K[M]^{\text{pr}}$  is identified with  $K[\hat{M}]$  and  $K(M)$  with a subfield of  $K(\hat{M})$ . Problems 6 and 1.27 imply that the domain of  $f \in K(M)$  on  $\hat{M}$  is a cone (perhaps without the vertex) over its domain on  $M$ . Problems 5 and 1.11 show that the irreducible components of  $\hat{M}$  are cones over the irreducible components of  $M$ .

**Problem 7.** The subfield  $K(M) \subset K(\hat{M})$  consists of all functions invariant with respect to homotheties, i.e. constant on generatrices of  $\hat{M}$ .

The described trick enables one to apply the affine theory to the study of projective varieties. In particular, it enables one to derive from Problems 1.30–1.32 their projective analogues.

Namely, let  $M \subset \mathbb{P}^n$  be an algebraic variety,  $M'$  the union of some of its irreducible components and  $M''$  the union of the remaining components. In exactly the same way as in the affine case the restriction homomorphism  $K(M) \rightarrow K(M')$  is defined.

**Problem 8.** If a function  $f$  is defined at  $x \in M'$  then so is  $f|_{M'}$  and  $f|_{M'}(x) = f(x)$ .

**Problem 9.** If a function  $f|_{M'}$  is defined at  $x \in M' \setminus M''$  then so is  $f$ .

**Problem 10.** Let  $M = M_1 \cup \dots \cup M_q$  be a decomposition of  $M$  into irreducible components. Then the homomorphism

$$K(M) \rightarrow K(M_1) \times \dots \times K(M_q), \quad f \mapsto (f|_{M_1}, \dots, f|_{M_q})$$

is an isomorphism.

**3°. Sheaves of Functions.** To consider affine and projective algebraic varieties from a unified point of view and to be able to define abstract projective and more general algebraic varieties introduce the notion of a topological space with a sheaf of functions or, briefly, of sheafed space.

One says that on a topological space  $M$  the *sheaf*  $\mathcal{O}$  of functions (or, more precisely, of algebras of functions) is defined if for any open subset  $U \subset M$  a subalgebra  $\mathcal{O}(U)$  is distinguished in the algebra of all continuous functions on  $U$  with values in  $K$  so that

(S1) if  $V \subset U$  and  $f \in \mathcal{O}(U)$  then  $f|_V \in \mathcal{O}(V)$

(S2) if  $U = \bigcup_{\alpha} U_{\alpha}$  and  $f$  is a function on  $U$  such that  $f|_{U_{\alpha}} \in \mathcal{O}(U_{\alpha})$  for all  $\alpha$  then  $f \in \mathcal{O}(U)$ .

When needed we will write  $\mathcal{O}_M$  instead of  $\mathcal{O}$ .

A continuous map  $f: M \rightarrow N$  of sheafed spaces is a *morphism* if  $f^*\mathcal{O}_N(V) \subset \mathcal{O}_M(f^{-1}(V))$  for any open subset  $V \subset N$ . Clearly, the composition of morphisms is a morphism.

A subspace  $N$  of a sheafed space  $M$  is canonically endowed with a sheaf of functions. Namely, a function  $f$  on an open subset  $V$  on  $M$  is assumed to belong to  $\mathcal{O}_N(V)$  if there exist open subsets  $U_{\alpha}$  of  $M$  and functions  $f_{\alpha} \in \mathcal{O}_M(U_{\alpha})$  such that  $V = N \cap (\bigcup_{\alpha} U_{\alpha})$  and  $f|_{N \cap U_{\alpha}} = f_{\alpha}|_{N \cap U_{\alpha}}$  for all  $\alpha$ .

**Problem 11.** This structure on  $N$  satisfies the axioms of the sheaf of functions.

The sheaf  $\mathcal{O}_N$  is called the *restriction* of  $\mathcal{O}_M$  onto  $N$ . Its definition implies that the identity embedding  $N \subset M$  is a morphism. If  $N$  is open in  $M$  then  $\mathcal{O}_N(V) = \mathcal{O}_M(V)$  for any open  $V \subset N$ .

**Problem 12.** The restriction of sheaves of functions is a transitive operation meaning that if  $P \subset N \subset M$  then the sheaf of functions on  $P$  obtained by consecutive restrictions of  $\mathcal{O}_M$  first onto  $N$  and then onto  $P$  coincides with the sheaf obtained by directly restricting  $\mathcal{O}_M$  onto  $P$ .

Let  $M$  and  $N$  be two sheafed spaces.

**Problem 13.** If  $f: M \rightarrow N$  is a morphism and  $f(M) \subset N_0 \subset N$  then  $f: M \rightarrow N_0$  is a morphism.

**Problem 14.** Let  $M = \bigcup_{\alpha} U_{\alpha}$  be an open covering. If a map  $f: M \rightarrow N$  is such that its restriction onto any subset  $U_{\alpha}$  is a morphism (into  $N$ ) then  $f$  is a morphism.

Now suppose  $M$  is irreducible (see 1.3). Any morphism of a nonempty open subset  $U \subset M$  into  $N$  will be called a *partial morphism* of  $M$  into  $N$ . Two partial morphisms are called *equivalent* if they coincide on the common domain.

**Problem 15.** The above is an equivalence relation on partial morphisms.

**Problem 16.** An equivalence class of partial morphisms contains a (unique) morphism whose domain contains the domains of all partial morphisms of the given class.

A partial morphism satisfying the conditions of this problem is called a *rational map* of  $M$  into  $N$ . Clearly, an everywhere defined rational map is a morphism.

A rational map  $f: M \rightarrow N$  is called *dominant* if  $f(M) = N$ . (In this case  $N$  is also irreducible).

The product of a dominant rational map  $f: M \rightarrow N$  and a rational map  $g: N \rightarrow P$  is a rational map  $gf: M \rightarrow P$  equivalent to any partial morphism of the

form  $g_0 f_0$ , where  $f_0$  and  $g_0$  are partial morphisms equivalent to  $f$  and  $g$  respectively and the image of  $f_0$  is contained in the domain of  $g_0$ . It is easy to see that such pairs  $(f_0, g_0)$  exist and if  $f$  is defined at  $x \in M$  and  $g$  is defined at  $f(x) \in N$  then  $gf$  is defined at  $x$  and  $(gf)(x) = g(f(x))$ ; however  $gf$  may also be defined at points which do not satisfy these conditions.

**4°. Sheaves of Algebras of Rational Functions.** Let  $M$  be an embedded affine or projective algebraic variety. In both cases the notion of a rational function is defined. For any open subset  $U \subset M$  denote by  $\mathcal{O}(U)$  the algebra of functions on  $U$  defined by restrictions onto  $U$  of rational functions whose domains contain  $U$ . (If  $U$  is dense in  $M$  then  $\mathcal{O}(U)$  is identified with a subalgebra of  $K(M)$ .)

**Problem 17.** This structure  $\mathcal{O}$  on  $M$  is a sheaf of functions.

This sheaf is called the *sheaf of (algebras of) rational functions*.

**Problem 18.** The sheaf  $\mathcal{O}$  on  $M$  coincides with the restriction onto  $M$  of the sheaf of rational functions on the hosting affine or projective space.

The open subset in  $\mathbb{P}^n$  defined by  $U_0 \neq 0$  can be identified with  $\mathbb{A}^n$  and the functions  $X_i = U_i/U_0$  ( $i = 1, \dots, n$ ) form a coordinate system in this  $\mathbb{A}^n$ . Therefore a point  $(X_1, \dots, X_n) \in \mathbb{A}^n$  is identified with the point  $(1 : X_1 : \dots : X_n) \in \mathbb{P}^n$ .

**Problem 19.** The sheaf of rational functions on  $\mathbb{A}^n$  coincides with the restriction of the sheaf of rational functions on  $\mathbb{P}^n$ .

**Problem 20.** Let  $M_h$  ( $h \in K[M]$ ) be a principal open subset of an affine variety  $M$ . The sheaf of rational functions on  $M_h$  as on an affine variety (see 1.8°) coincides with the restriction of the sheaf of rational functions on  $M$ .

**Problem 21.** The morphisms of affine varieties are the same as their morphisms as of sheafed spaces.

This means that affine varieties can be considered as special objects in the category of sheafed spaces. Namely an (abstract) affine algebraic variety is a sheafed space isomorphic to a closed subset of an affine space.

**Problem 22.** The rational maps of irreducible affine varieties (see 1.9°) are the same as their rational maps as of sheafed spaces (see 3°).

Similarly, an (abstract) projective algebraic variety is defined as a sheafed space isomorphic to a closed subset of a projective space. The *morphisms of projective varieties* are by definition the morphisms of sheafed spaces.

**5°. Quasiprojective Varieties.** A *quasiprojective algebraic variety* (or simply a *quasiprojective variety*) is a sheafed space isomorphic to an open subset of a projective variety or, which is the same, a locally closed subset of a projective space.

Affine and projective algebraic varieties are particular cases of quasiprojective ones. These cases exclude each other. More precisely, if an irreducible quasiprojective variety  $M$  is simultaneously affine and projective then it consists of one

point. Indeed, if  $M$  is affine then  $\mathcal{O}(M) = K[M]$ , and if  $M$  is projective then  $\mathcal{O}(M) = K$  (Theorem 1). Therefore if it is both affine and projective then  $K[M] = K$ , but for an affine variety this means that it consists of one point.

A locally closed subset of a quasiprojective variety  $M$  (endowed with the induced topology and a sheaf of functions which is the restriction of the sheaf  $\mathcal{O}_M$ ) is called a *subvariety* of  $M$ . Clearly, it is also a quasiprojective variety; any closed subvariety of an affine (resp. projective) variety is affine (resp. projective).

By definition any quasiprojective variety  $M$  can be embedded as an open subvariety into a projective variety  $P$ . Assuming that  $M$  is dense in  $P$  (we can always do this without loss of generality) set  $K(M) = K(P)$  and consider each element of  $K(M)$  as a function on  $M$  which is the restriction of the corresponding rational function on  $P$ . The functions on  $M$  obtained in this way will also be called *rational* ones. They are characterized in inner terms as the functions from  $\mathcal{O}_M$  whose domains cannot be extended.

On the other hand,  $\mathcal{O}_M$  is completely defined by the algebra of rational functions on  $M$  since for any open subset  $U \subset M$  the functions from  $\mathcal{O}_M(U)$  are nothing but the restrictions of rational functions.

Clearly, if  $M_0 \subset M$  is a dense open subvariety then there exists a natural isomorphism of algebras  $K(M)$  and  $K(M_0)$  which to any rational function on  $M$  assigns its restriction onto  $M_0$ .

The following problems show that quasiprojective varieties can be in a sense approximated by affine ones and their morphisms by morphisms of affine varieties.

**Problem 23.** For any finite set of points of a quasiprojective variety there exists a dense open affine subvariety containing it.

**Problem 24.** For any morphism  $f: M \rightarrow N$  of quasiprojective varieties there exist dense open affine subvarieties  $M_0 \subset M$  and  $N_0 \subset N$  such that  $f(M_0) \subset N_0$  (and then the map  $f: M_0 \rightarrow N_0$  is automatically a morphism, cf. Problem 13). Moreover, we may require that  $M_0$  and  $N_0$  contain any prescribed finite sets of points of  $M$  and  $N$  respectively.

Due to this, Theorems 1.5 and 1.8 are obviously generalized to any quasiprojective varieties. Let us formulate theorems thus obtained.

**Theorem 2.** Let  $f: M \rightarrow N$  be a dominant morphism of irreducible quasiprojective varieties. Then  $f(M)$  is an *épais* subset of  $N$ .

**Theorem 3.** Let  $\text{char } K = 0$ , let  $M, N, P$  be irreducible quasiprojective varieties, and let  $f: M \rightarrow N$ ,  $h: M \rightarrow P$  be dominant morphisms. If  $f(x') = f(x'')$  implies  $h(x') = h(x'')$  for any  $x', x'' \in M$  then there exists a (dominant) rational map  $g: N \rightarrow P$  such that  $h = gf$ .

Clearly, a complex quasiprojective variety is projective if and only if it is compact in a real topology.

**6°. The Direct Product.** The direct product  $M \times N$  of affine varieties  $M$  and  $N$  defined in 1.4° is their set-theoretic direct product endowed with an affine

variety structure. Let us characterize this structure in terms meaningful for any quasiprojective varieties.

**Problem 25:** The projections of the direct product  $M \times N$  onto  $M$  and  $N$  are morphisms. For any affine variety  $P$  and morphisms  $f: P \rightarrow M$  and  $g: P \rightarrow N$  the map

$$P \rightarrow M \times N, \quad z \mapsto (f(z), g(z))$$

is a morphism.

Taking this as a guide, give the following axiomatic definition of the *direct product of quasiprojective varieties*  $M_1, \dots, M_k$ : it is their set-theoretical direct product  $M_1 \times \cdots \times M_k$  endowed with a quasiprojective variety structure so that

(P1) the projections  $p_i: M_1 \times \cdots \times M_k \rightarrow M_i$  ( $i = 1, \dots, k$ ) are morphisms;

(P2) for any quasiprojective variety  $P$  and any morphisms  $f_i: P \rightarrow M_i$  ( $i = 1, \dots, k$ ) the map

$$P \rightarrow M_1 \times \cdots \times M_k, \quad z \mapsto (f_1(z), \dots, f_k(z))$$

is a morphism.

**Problem 26.** On  $M_1 \times \cdots \times M_k$ , there exists no more than one quasiprojective variety structure satisfying these axioms.

(The existence of such a structure, however, is not clear from the definition.)

Thanks to Problem 14 and the existence of an open covering of any quasiprojective variety by affine subvarieties (Problem 23) one may confine oneself in the above definition to affine varieties  $P$ . Therefore the direct product of affine varieties in the sense of 1.4 is also their direct product in the sense of the new definition.

The direct product topology of quasiprojective varieties should not coincide with the topology of the direct product of topological spaces and in nontrivial cases never coincides with the latter (see 1.3). However, the following problem shows that in any case the direct product topology is not weaker than the latter one.

**Problem 27.** Let  $M_1 \times \cdots \times M_k$  be the direct product of quasiprojective varieties  $M_1, \dots, M_k$  and  $N_i \subset M_i$  ( $i = 1, \dots, k$ ) be locally closed (resp. open, closed) subsets. Then  $N_1 \times \cdots \times N_k$  is a locally closed (resp. open, closed) subset of  $M_1 \times \cdots \times M_k$ . Endowed with a quasiprojective variety structure as a subvariety of  $M_1 \times \cdots \times M_k$  it is the direct product of varieties  $N_1, \dots, N_k$ .

Now, let us consider the question of the existence of the direct product.

**Theorem 4.** For any quasiprojective varieties  $M_1, \dots, M_k$  there exists their direct product  $M_1 \times \cdots \times M_k$  and if  $M_1, \dots, M_k$  are affine (resp. projective) varieties then so is  $M_1 \times \cdots \times M_k$ . The direct product of irreducible varieties is an irreducible variety.

The following problem enables us to reduce the proof to the case of two factors.

**Problem 28.** Let  $M_1 \times \cdots \times M_{k-1} = N$  be the direct product of quasiprojective varieties  $M_1, \dots, M_{k-1}$ , and  $N \times M_k$  be the direct product of  $N$  and  $M_k$ . Then  $N \times M_k$  naturally identified with  $M_1 \times \cdots \times M_k$  is the direct product of  $M_1, \dots, M_k$ .

Furthermore, since any quasiprojective variety is by definition a subvariety of a projective space, Problem 27 shows that it suffices to prove the existence of the direct product of projective spaces. For this let us make use of the following criterion.

**Problem 29.** Let  $M = \bigcup_{\alpha} M_{\alpha}$  and  $N = \bigcup_{\beta} N_{\beta}$  be open coverings of quasiprojective varieties  $M$  and  $N$  and let a quasiprojective variety structure on  $M \times N$  be introduced so that the subvariety  $M_{\alpha} \times N_{\beta} \subset M \times N$  is the direct product of varieties  $M_{\alpha}$  and  $N_{\beta}$  for any  $\alpha, \beta$ . Then  $M \times N$  is the direct product of  $M$  and  $N$ .

Now let  $\mathbb{P}^n$  and  $\mathbb{P}^m$  be the projective spaces with homogeneous coordinates  $U_i$  ( $i = 0, 1, \dots, n$ ) and  $V_j$  ( $j = 0, 1, \dots, m$ ) respectively. Consider the projective space  $\mathbb{P}^{nm+n+m}$  with homogeneous coordinates  $W_{ij}$  ( $i = 0, 1, \dots, n; j = 0, 1, \dots, m$ ) and the map

$$\eta: \mathbb{P}^n \times \mathbb{P}^m \rightarrow \mathbb{P}^{nm+n+m}$$

defined by the formulas  $W_{ij} = U_i V_j$ .

**Problem 30.** The map  $\eta$  is one-to-one. Its image is closed in  $\mathbb{P}^{nm+n+m}$ .

Identifying  $\mathbb{P}^n \times \mathbb{P}^m$  with its image under  $\eta$  we introduce on it a projective variety structure.

Let us identify the open subsets of  $\mathbb{P}^n$ ,  $\mathbb{P}^m$  and  $\mathbb{P}^{nm+n+m}$  distinguished by the inequalities

$$U_0 \neq 0, \quad V_0 \neq 0, \quad W_{00} \neq 0, \quad (2)$$

respectively, with the affine spaces  $\mathbb{A}^n$ ,  $\mathbb{A}^m$  and  $\mathbb{A}^{nm+n+m}$  (see 4°). We have

$$\eta(\mathbb{A}^n \times \mathbb{A}^m) \subset \mathbb{A}^{nm+n+m}.$$

**Problem 31.** The map  $\eta$  induces the isomorphism of  $\mathbb{A}^n \times \mathbb{A}^m = \mathbb{A}^{n+m}$  onto a closed subvariety of  $\mathbb{A}^{nm+n+m}$ .

This means that the projective variety structure introduced on  $\mathbb{P}^n \times \mathbb{P}^m$  induces a direct product structure on  $\mathbb{A}^n \times \mathbb{A}^m$ . Since instead of  $U_0$ ,  $V_0$  and  $W_{00}$  in (2) we might have taken  $U_i$ ,  $V_j$  and  $W_{ij}$  with any  $i, j$ , then the conditions of Problem 29 are satisfied, hence  $\mathbb{P}^n \times \mathbb{P}^m$  is actually the direct product of  $\mathbb{P}^n$  and  $\mathbb{P}^m$ .

We have therefore simultaneously proved the first statement of the theorem and the fact that the direct product of projective varieties is a projective variety. The fact that the direct product of affine varieties is an affine variety had actually already been proved in § 1. The irreducibility of the direct product of irreducible varieties is proved as in the affine case (Problem 1.14).

It is useful to describe the topology of  $\mathbb{P}^n \times \mathbb{P}^m$  in the inner terms.

**Problem 32.** A subset  $F \subset \mathbb{P}^n \times \mathbb{P}^m$  is closed if and only if it can be defined by a system of equations of the form

$$p(U_0, U_1, \dots, U_n; V_0, V_1, \dots, V_m) = 0,$$

where  $p$  is a polynomial homogeneous separately in  $U_0, U_1, \dots, U_n$  and in  $V_0, V_1, \dots, V_m$ .

**7°. Flag Varieties.** Let  $V$  be an  $n$ -dimensional vector space.

A *flag* in  $V$  is a set  $\{V_1, \dots, V_n\}$  of its subspaces such that  $\dim V_k = k$  and  $V_k \subset V_{k+1}$  ( $k = 1, \dots, n-1$ ).

In this subsection we aim to introduce a natural structure of a projective algebraic variety on the set of flags. This variety is called the *flag variety* and plays an important role in the theory of algebraic groups.

Let  $\Lambda(V) = \bigoplus_{k \geq 0} \Lambda^k(V)$  be the *exterior (Grassmann) algebra* of  $V$  (see [50, 52]). The elements of  $\Lambda^k(V)$  are called *k-vectors*. There is a canonical isomorphism  $\theta$  between the space  $\Lambda^k V$  and the space of the  $k$ -th degree skewsymmetric tensors, defined by the formula

$$\theta(x_1 \wedge \dots \wedge x_k) = \sum (-1)^{\text{parity of } \sigma} x_{\sigma(1)} \otimes \dots \otimes x_{\sigma(k)},$$

where  $\sigma$  runs through all permutations.

A nonzero  $k$ -vector is called *simple* (or *decomposable*) if it can be presented in the form  $x_1 \wedge \dots \wedge x_k$ , where  $x_i \in V$ . The above isomorphism defines a coordinate system in  $\Lambda^k V$  in which coordinates of a simple  $k$ -vector  $x_1 \wedge \dots \wedge x_k$  are the  $k$ -th order minors of the matrix formed by the coordinates of vectors  $x_1, \dots, x_k$  in a fixed basis of  $V$ . These are the *Plücker coordinates*.

**Problem 33.** Suppose  $u = x_1 \wedge \dots \wedge x_k$  is a simple  $k$ -vector. The subspace  $V(u) \subset V$  spanned by the vectors  $x_1, \dots, x_k$  is uniquely recovered from  $u$  as follows:

$$V(u) = \{x \in V: u \wedge x = 0\} \quad (3)$$

Clearly, a simple  $k$ -vector  $u$  is defined by the subspace  $V(u)$  up to a factor. Thus, there is a one-to-one correspondence between the  $k$ -dimensional subspaces of  $V$  and the one-dimensional subspaces of  $\Lambda^k V$  consisting of simple  $k$ -vectors.

**Problem 34.** If a nonzero  $k$ -vector  $u$  is not simple then  $\dim V(u) < k$ , where  $V(u) \subset V$  is constructed in (3).

Let  $P(U)$  be the projective space associated with the vector space  $U$ . (The points of  $P(U)$  are the one-dimensional subspaces of  $U$ ). In accordance with the above, the set of all  $k$ -dimensional subspaces of  $V$  is identified with some subset  $\text{Gr}_k(V) \subset P(\Lambda^k V)$  called the *Grassmann variety*.

**Problem 35.**  $\text{Gr}_k(V)$  is closed in  $P(A^k V)$ .

Let us prove that the Grassmann variety is irreducible. Let  $E(V)$  be the set of all frames of  $V$ . There is a surjective map

$$g_k: E(V) \rightarrow \text{Gr}_k(V),$$

which to each basis assigns the subspace spanned by the first  $k$  of its elements. The set  $E(V)$  is endowed with the structure of an irreducible affine variety as a principal open subset of the irreducible affine variety  $V \times \cdots \times V$  ( $n$  factors).

**Problem 36.** The map  $g_k$  is a morphism of  $E(V)$  into  $P(A^k V)$ .

Since the image of an irreducible topological space under a continuous mapping is irreducible, the above implies that  $\text{Gr}_k(V)$  is irreducible.

Let  $1 \leq k < l \leq n$ . Consider the subset  $\text{Gr}_{k,l}(V) \subset \text{Gr}_k(V) \times \text{Gr}_l(V)$  consisting of pairs  $(W, U)$  of subspaces, such that  $\dim W = k$ ,  $\dim U = l$  and  $W \subset U$ .

**Problem 37.** The subspace  $\text{Gr}_{k,l}(V)$  is closed in  $\text{Gr}_k(V) \times \text{Gr}_l(V)$ .

The set  $F(V)$  of all flags of  $V$  is a subset in the direct product  $\text{Gr}_1(V) \times \cdots \times \text{Gr}_n(V)$ .

**Problem 38.** The set  $F(V)$  is closed in  $\text{Gr}_1(V) \times \cdots \times \text{Gr}_n(V)$ .

**Problem 39.** The set  $F(V)$  is irreducible.

Thus, the set  $F(V)$  is an irreducible closed subset of the projective variety  $\text{Gr}_1(V) \times \cdots \times \text{Gr}_n(V)$  and due to this fact it is endowed with an irreducible projective variety structure. This variety is called the *flag variety* of  $V$ .

### Exercises

- 1) The projective variety  $M^{pr}(S)$  defined by (1) is empty if and only if there exists  $k$  such that the ideal of  $K[U_0, U_1, \dots, U_n]$  generated by  $S$  contains all the forms of degree  $k$  (therefore all forms of greater degrees as well).
- 2) Let  $S = \{p_1, p_2, \dots\}$  be the set of forms of degrees  $k_1, k_2, \dots$  respectively. For given  $k_1, k_2, \dots$  the necessary and sufficient conditions for  $M^{pr}(S)$  to be nonempty can be expressed in the form of a system of algebraic relations in the coefficients of forms  $p_1, p_2, \dots$  each of relations being homogeneous in the coefficients of each form. (Each relation contains coefficients of only a finite number of forms.)
- 3) Let  $M \subset \mathbb{P}^n$  be an irreducible algebraic variety. An ordered set  $(p_0, p_1, \dots, p_m)$  of homogeneous elements of equal degree from  $K[M]^{pr}$  is *admissible* if it contains at least one nonzero element. Admissible sets  $(p_0, p_1, \dots, p_m)$  and  $(q_0, q_1, \dots, q_m)$  are *equivalent* if  $p_i q_j = p_j q_i$  for all  $i, j$ .  
This equivalence relation is well-defined.
- 4) Each equivalence class of admissible sets defines a map (perhaps not everywhere defined)  $f: M \rightarrow \mathbb{P}^m$  according to the following rule:  $f$  is defined at  $x \in M$  if the given class contains a set  $(p_0, p_1, \dots, p_m)$  such that  $p_i(x) \neq 0$  for some  $i$  and in this case

$$f(x) = (p_0(x) : p_1(x) : \dots : p_m(x)).$$

This is a rational map (in the sense of 3°).

- 5) Any rational map  $f: M \rightarrow \mathbb{P}^m$  is defined in the above sense by an equivalence class of admissible sets.
- 6) Any rational map  $f: \mathbb{P}^1 \rightarrow \mathbb{P}^m$  is a morphism, i.e. is defined everywhere.
- 7) Find the image of the morphism  $\mathbb{P}^1 \rightarrow \mathbb{P}^m$  defined by the set  $(U_0^m, U_0^{m-1}U_1, \dots, U_1^m)$ .
- 8) Find the domain and the range of the rational map  $f: \mathbb{P}^2 \rightarrow \mathbb{P}^2$  defined by  $(U_1U_2, U_2U_0, U_0U_1)$ . Prove that  $f^2 = id$ .
- 9) Let  $M \subset \mathbb{P}^2$  be the conic defined by  $U_0^2 - U_1^2 - U_2^2 = 0$  and  $f: M \rightarrow \mathbb{P}^1$  the rational map (stereographic projection) defined by the set  $(u_0 - u_1, u_2)$ , where  $u_0, u_1, u_2$  are the images of  $U_0, U_1, U_2$  under the canonical homomorphism  $K[U_0, U_1, U_2] \rightarrow K[M]^{pr}$ . Prove that  $f$  is an isomorphism.
- 10) The image of any morphism of a projective variety into a quasiprojective variety is closed. (Hint: make use of Exercises 5 and 2.)
- 11) Let  $M = M(S)$  be an algebraic variety in  $\mathbb{A}^n$  defined by the system of equations (1.1) and  $\tilde{M}$  an algebraic variety in  $\mathbb{P}^n$  defined by the system

$$U_0^{\deg f} f\left(\frac{U_1}{U_0}, \dots, \frac{U_n}{U_0}\right) = 0$$

The closure  $\overline{M}$  of  $M$  in  $\mathbb{P}^n$  coincides with the union of irreducible components of  $\tilde{M}$  which are not entirely contained in the hyperplane  $U_0 = 0$ .

- 12) In the notation of Exercise 11, if  $S = \{X_1, X_1^2 + X_2\}$  then  $\overline{M} \neq \tilde{M}$ .
- 13) In any quasiprojective variety the open affine subvarieties constitute a basis of its topology.

### Hints to Problems

- 1, 2. Consider the highest components of nilpotent elements and of zero divisors respectively.
3. Deduce from Hilbert's theorem on the basis of an ideal.
5. Is proved similarly to Problem 1.11.
6. Let  $M = M_1 \cup \dots \cup M_q$  be a decomposition of  $M$  into irreducible components and  $I_s$  ( $s = 1, \dots, q$ ) the ideal of  $K[M]^{pr}$  generated by the homogeneous elements that vanish on  $M_s$ . Since  $I_f$  contains homogeneous nondivisors of zero, then there exists a homogeneous element  $q \in I_f$  which does not belong to any of the  $I_s$ . Let  $x \in M$  be a point which does not belong to the set of zeros of  $I_f$  and  $r \in I_f$  a homogeneous element such that  $r(x) \neq 0$ . Replacing  $q$  and  $r$  by their appropriate powers we may achieve that  $\deg q = \deg r$ . An appropriate linear combination of  $q$  and  $r$  is then a nondivisor of zero contained in  $I_f$  and does not vanish at  $x$ . Therefore  $x \in D_f$ .
7. If  $f \in K[\tilde{M}]$  is invariant with respect to homotheties then so is the ideal  $I_f$  of  $K[M] = K[M]^{pr}$ , i.e.  $I_f$  is homogeneous. We must prove that it contains homogeneous nondivisors of zero. Since it contains some nondivisors of

zero, then in the notation of the solution of Problem 6  $I_f \not\subset I_s$  for any  $s$ . Therefore, for any  $s$  there exists a homogeneous element  $q_s \in I_f$  such that  $q_s \notin I_s$ . We may assume (see the solution of Problem 6) that the degrees of all these elements are equal. Then their appropriate linear combination is the required homogeneous nondivisor of zero.

10. Make use of Problem 7.
17. To verify axiom (S2) in the affine case make use of Problem 1.31 and 1.32 and in the projective case make use of Problems 9 and 10.
18. Due to axiom (S2), it suffices to prove the statement for an irreducible  $M$ .
23. Let a given quasiprojective variety  $M$  be embedded as a subvariety into  $\mathbb{P}^n$ . By an appropriate projective transformation we can achieve that none of the given points and none of the irreducible components of  $M$  belong to the hyperplane  $U_0 = 0$ . Then  $M \cap \mathbb{A}^n$  is a dense open subset of  $M$  containing all the given points. Furthermore in the affine variety  $\overline{M} \cap \mathbb{A}^n$  there exists a principal open subset contained in  $M \cap \mathbb{A}^n$  and containing all the given points. This is the desired subvariety of  $M$ .
24. First, choose a subvariety  $N_0 \subset N$  which contains at least one point of the image of every irreducible component of  $M$ .
25. This is a geometric reformulation of the properties of the tensor product of algebras (see 1.4).
27. Make use of Problem 13.
29. For any morphisms  $f: P \rightarrow M$  and  $g: P \rightarrow N$  consider their restrictions onto  $P_{\alpha\beta} = f^{-1}(M_\alpha) \cap g^{-1}(N_\beta)$  and make use of Problem 14.
30. If we arrange the homogeneous coordinates of a point of  $\mathbb{P}^{nm+n+m}$  into an  $(n+1) \times (m+1)$ -matrix then the image of  $\eta$  consists of the points whose matrix of coordinates is of rank 1 and is determined by the conditions that the second order minors of this matrix vanish.
31. Follows from the fact that among the coordinates of the point

$$\eta((X_1, \dots, X_n), (Y_1, \dots, Y_m)) \in \mathbb{A}^{nm+n+m}$$

some are equal to  $X_1, \dots, X_n, Y_1, \dots, Y_m$  and the remaining ones are their products.

32. Let the subset  $F$  be defined by equations of the form mentioned in the conditions of the problem. Suppose one of these equations is of the form  $p = 0$ , where  $p$  is a quasihomogeneous polynomial of degree  $k$  in  $U_0, U_1, \dots, U_n$  and of degree  $l$  in  $V_0, V_1, \dots, V_m$ . If, say,  $k > l$  then multiplying  $p = 0$  by all monomials of degree  $k - l$  in  $V_0, V_1, \dots, V_m$  we obtain a system of equations equivalent to the initial equation and consisting of equations of homogeneity degree  $k$  in each group of coordinates. Therefore, we may require that each of equations that determine  $F$  have the same homogeneity degree in both groups of coordinates. The equations of this form can be presented as homogeneous equations in the products  $U_i V_j$ , where  $i = 0, 1, \dots, n$  and  $j = 0, 1, \dots, m$ , yielding the closedness of  $F$ . The converse is obvious.

- 34. Let  $(x_1, \dots, x_l)$  be a basis of the subspace  $V(u)$ . Let us complete this basis to a basis of the space  $V$  by vectors  $x_{l+1}, \dots, x_n$ . Let  $u = \sum_{i_1 < \dots < i_k} u_{i_1 \dots i_k} x_{i_1} \wedge \dots \wedge x_{i_k}$ . The relations  $u \wedge x_i = 0$  for  $i = 1, \dots, l$  imply that  $u_{i_1 \dots i_k} = 0$  if at least one of  $1, \dots, l$  is not one of  $i_1, \dots, i_k$ . It follows that  $l \leq k$  and if  $l = k$  then  $u = cx_1 \wedge \dots \wedge x_l$  for  $c \in \mathbb{C}$ .
- 35. Problems 33 and 34 imply that a  $k$ -vector  $x$  is simple if and only if the rank of the linear map  $x \mapsto u \wedge x$  is not greater than  $n - k$  (and in this case it equals  $n - k$ ). The latter is equivalent to the vanishing of all minors of order  $n - k + 1$  of the matrix of this map.
- 36. The map  $g_k$  is defined by the  $k$ -th order minors of the matrix constructed from the coordinates (in a fixed basis) of the first  $k$  vectors of a basis.
- 37. Let  $u$  be a simple  $k$ -vector and  $v$  a simple  $l$ -vector. Problem 33 implies that  $V(u) \subset V(v)$  if and only if the rank of the linear map

$$V \rightarrow A^{k+1}V \oplus A^{l+1}V, \quad x \mapsto (u \wedge x, v \wedge x)$$

is not greater than  $n - k$  (and in this case it automatically equals  $n - k$ ).

- 38. Follows from Problem 37.
- 39. The proof follows the line of the proof of irreducibility of  $\text{Gr}_k(V)$ .

### §3. Dimension and Analytic Properties of Algebraic Varieties

In this section “algebraic varieties” are understood as quasiprojective algebraic varieties (but other varieties will do if the reader knows what those concepts mean).

**1°.** **Definition of the Dimension and its Main Properties.** Let  $A$  be an algebra without zero divisors. Elements  $u_1, \dots, u_m \in A$  are called *algebraically independent* (over  $K$ ) if they do not satisfy any nontrivial algebraic relation with coefficients in  $K$ . In such a case  $K[u_1, \dots, u_m] \cong K[X_1, \dots, X_m]$ . A maximal algebraically independent system of elements is called a *transcendence basis* of  $A$ .

**Problem 1.** Algebraically independent elements  $u_1, \dots, u_m \in A$  form a transcendence basis if and only if  $A$  is an algebraic extension of a subalgebra  $K[u_1, \dots, u_m]$  (see 1.5).

**Problem 2.** Let  $A = K[u_1, \dots, u_n]$  and  $\{u_1, \dots, u_m\}$  be a maximal algebraically independent subsystem of  $\{u_1, \dots, u_n\}$ . Then  $\{u_1, \dots, u_m\}$  is a transcendence basis of  $A$ .

**Problem 3.** Any transcendence basis of  $A$  is a transcendence basis of  $QA$ .

**Theorem 1.** *If  $A$  has a transcendence basis of  $m$  elements, then any  $n > m$  of its elements are algebraically dependent.*

Proof see e.g. in [52]. Another proof will be given in 2°.

**Corollary.** *All transcendence bases of  $A$  contain the same number of elements.*

This number is called the *transcendence degree* of  $A$  and denoted  $\text{tr. deg } A$ . If  $A$  has no (finite) transcendence basis we set  $\text{tr. deg } A = \infty$ .

Clearly, the transcendence degrees of a subalgebra and a quotient algebra do not exceed the transcendence degree of the algebra. By Problem 3  $\text{tr. deg } A = \text{tr. deg } QA$ . Finally,  $\text{tr. deg } K[X_1, \dots, X_n] = n$ .

The *dimension* of an irreducible algebraic variety  $M$  is  $\dim M = \text{tr. deg } K(M)$ . The *dimension* of an arbitrary algebraic variety is the maximum of dimensions of its irreducible components. Clearly, the dimension of a variety equals the dimension of any of its dense open subvarieties and  $\dim \mathbb{P}^n = \dim \mathbb{A}^n = n$ .

**Problem 4.** If  $N$  is a subvariety of an algebraic variety  $M$  then  $\dim N \leq \dim M$ .

**Problem 5.** Under the conditions of Problem 4, if  $M$  is irreducible and  $N$  is closed in  $M$ , then  $\dim N = \dim M$  implies  $N = M$ .

**Theorem 2.** *Any non-descending chain  $N_1 \subset N_2 \subset \dots$  of irreducible closed subsets in an algebraic variety  $M$  is stable.*

**Problem 6.** Prove Theorem 2.

**2°. Derivations of the Algebra of Functions.** Let  $\varphi$  be a homomorphism of an algebra  $A$  without zero divisors into a field  $L$  containing  $K$  (and considered as a  $K$ -algebra). A linear map  $\partial: A \rightarrow L$  is called a  $\varphi$ -*derivation of  $A$  into  $L$*  if

$$\partial(ab) = \partial(a)\varphi(b) + \varphi(a)\partial(b), \quad (1)$$

for any  $a, b \in A$ . It is easy to see that  $\partial(1) = 0$ . The set of all  $\varphi$ -derivations of  $A$  into  $L$  is a vector space over  $L$  with respect to the natural operations:

$$\begin{aligned} (\partial_1 + \partial_2)(a) &= \partial_1(a) + \partial_2(a), \\ (\lambda\partial)(a) &= \lambda\partial(a) \quad \text{for } \lambda \in L. \end{aligned} \quad (2)$$

This space will be denoted by  $D(A, L)$ .

**Problem 7.** Let  $A = K[X_1, \dots, X_n]$ . Then for any  $\lambda_1, \dots, \lambda_n \in L$  there exists a unique  $\varphi$ -derivation  $\partial: A \rightarrow L$  which transforms  $X_i$  into  $\lambda_i$  for  $i = 1, \dots, n$ .

Clearly, under the conditions of Problem 7  $\dim D(A, L) = n$ .

Consider a particular case, when  $A \subset L$  and  $\varphi = \text{id}$ . In this case we will simply speak about a derivation of  $A$  into  $L$ .

**Problem 8.** Any derivation  $\partial: A \rightarrow L$  uniquely extends to a derivation  $QA \rightarrow L$ .

**Problem 9.** Let  $B \subset L$  be a subalgebra finitely generated over  $A$ . If  $B$  is an algebraic extension of  $A$ , then any derivation  $\partial: A \rightarrow L$  uniquely extends to a derivation  $B \rightarrow L$ .

**Problem 10.** If  $A \subset L$  is a finitely generated algebra, then  $\dim D(A, L) = \text{tr. deg } A$ .

Theorem 1 easily follows from Problem 10: take  $QA$  instead of  $L$ . Thus, if  $M$  is an irreducible algebraic variety then

$$\dim M = \dim D(K(M), K(M)). \tag{3}$$

**Theorem 3.** Let  $M \subset \mathbb{A}^n$  be an irreducible algebraic variety and  $\{f_1, \dots, f_m\}$  a system of generators of  $I(M)$ . Let  $r$  be the rank of  $J = \left. \frac{\partial(f_1, \dots, f_m)}{\partial(X_1, \dots, X_n)} \right|_M$  (as of a matrix with entries in  $K(M)$ ). Then  $\dim M = n - r$ .

To prove the theorem first of all note that  $\dim M = \dim D(K[M], K(M))$ . Further,  $K[M] \cong K[X_1, \dots, X_n]/I(M)$ . Let  $\pi$  be a homomorphism of  $K[X_1, \dots, X_n]$  into the field  $K(M)$  defined by the formula  $\pi(f) = f|_M$ . To any derivation  $\partial: K[M] \rightarrow K(M)$  assign a  $\pi$ -derivation  $\tilde{\partial}: K[X_1, \dots, X_n] \rightarrow K(M)$  by the formula  $\tilde{\partial}f = \partial\pi(f)$ .

**Problem 11.** The map  $\partial \mapsto \tilde{\partial}$  is an isomorphism of the space  $D(K[M], K(M))$  onto the space of  $\pi$ -derivations of  $K[X_1, \dots, X_n]$  into  $K(M)$  that vanish on  $I(M)$ .

**Problem 12.** Prove Theorem 3.

**3°. Simple Points.** Let  $M$  be an irreducible algebraic variety in  $\mathbb{A}^n$  and  $J$  a matrix with entries from  $K[M]$  constructed as in Theorem 3. A point  $x \in M$  is *simple*, if  $\text{rk } J(x) = \text{rk } J$ .

This definition has, actually, an intrinsic sense. Moreover, for any point  $x \in M$  the number  $n - \text{rk } J(x)$  does not depend on an embedding of  $M$  into an affine space. The proof of this fact is similar to that of Theorem 3. Consider the homomorphism

$$\varphi_x: K[M] \rightarrow K, \quad f \mapsto f(x)$$

and denote by  $D_x(K[M], K)$  the space of all  $\varphi_x$ -derivations of  $K[M]$  into the field  $K$ . The elements of this space are the linear maps  $\partial: K[M] \rightarrow K$  satisfying

$$\partial(fg) = \partial f \cdot g(x) + f(x) \cdot \partial g.$$

**Problem 13.**  $\dim D_x(K[M], K) = n - \text{rk } J(x)$ .

In particular, since  $\text{rk } J(x) \leq \text{rk } J = r$ , then  $\dim D_x(K[M], K) \geq n - r = \dim M$ , and the equality holds if and only if  $x$  is a simple point of  $M$ . This gives an intrinsic characterization of simple points of irreducible affine varieties.

The notion of a simple point may be extended to arbitrary algebraic varieties. To do this let us give a local definition of a simple point of an irreducible affine variety  $M$  that does not involve  $K[M]$ .

For a point  $x \in M$  define its local algebra  $O_x$  as the algebra of all rational functions on  $M$  defined at  $x$ .

**Problem 14.** Any  $\varphi_x$ -derivation of  $K[M]$  into  $K$  uniquely extends to a  $\varphi_x$ -derivation of  $O_x$  into  $K$ .

Now, denote by  $D_x(O_x, K)$  the space of all  $\varphi_x$ -derivations of  $O_x$  into  $K$ . Problems 13 and 14 imply that  $x$  is simple if and only if

$$\dim D_x(O_x, K) = \dim M. \quad (4)$$

For an *irreducible quasiprojective variety*  $M$  the equality (4) is understood as a definition of a *simple point*. The local algebra  $O_x$  in this situation is defined exactly as in the affine case, i.e. as the algebra of all rational functions on  $M$  defined at  $x$ .

The set of all simple points of  $M$  is denoted by  $M^{\text{reg}}$ .

**Problem 15.** Let  $N$  be an open subvariety of an irreducible algebraic variety  $M$ . Then  $N^{\text{reg}} = N \cap M^{\text{reg}}$ .

**Problem 16.** The set  $M^{\text{reg}}$  is non-empty and open in  $M$ .

Finally, a point of a reducible algebraic variety  $M$  is *simple* if it is a simple point of an irreducible component of  $M$  of the maximal dimension and is not contained in any other irreducible component.

All points of an algebraic variety  $M$  which are not simple are called *singular*. A variety  $M$  is called *non-singular* if it has no singular points. Clearly, it is so if and only if all irreducible components of  $M$  are non-singular, have the same dimension and have empty intersections.

Problem 16 and the definition of simple points of reducible varieties imply that the set of singular points is always a closed subvariety whose dimension is strictly less than that of the variety itself.

**Problem 17.** Any algebraic variety  $M$  is the union of a finite number of nonintersecting nonsingular subvarieties.

**4°. The Analytic Structure of Complex and Real Algebraic Varieties.** The *dimension of a real affine variety*  $M$  is the dimension of its complexification  $M(\mathbb{C})$ ; a point  $x \in M$  is *simple* if it is a simple point of  $M(\mathbb{C})$ . Clearly, simple points constitute a nonempty open subset of  $M$ . It is denoted by  $M^{\text{reg}}$ .

**Theorem 4.** Let  $M$  be a  $d$ -dimensional irreducible algebraic variety in a complex or real affine space  $\mathbb{A}^n$ . Then  $M^{\text{reg}}$  is a  $d$ -dimensional analytic subvariety of  $\mathbb{A}^n$ .

In both cases the theorem is proved similarly. Let  $K$  stand for  $\mathbb{C}$  in the first case and for  $\mathbb{R}$  in the second case. Let  $f_1, \dots, f_m \in K[X_1, \dots, X_n]$  be a system of generators of  $I(M)$  and  $J$  a matrix with entries from  $K[M]$  constructed as in Theorem 3.

Let  $x \in M(K)$  be a simple point. We may assume that the minor  $\Delta = \frac{D(f_1, \dots, f_r)}{D(X_1, \dots, X_r)}$  of the matrix  $\frac{\partial(f_1, \dots, f_m)}{\partial(X_1, \dots, X_n)}$  is non-zero at  $x$  and all the bordering minors vanish identically on  $M$ .

**Problem 18.** There exist  $g_{ik} \in K[X_1, \dots, X_n]$ , where  $i = 1, \dots, m$  and  $k = 1, \dots, r$ , such that

$$\Delta \frac{\partial f_i}{\partial X_j} \equiv \sum_{1 \leq k \leq r} g_{ik} \frac{\partial f_k}{\partial X_j} \pmod{I(M)} \quad (i = 1, \dots, m; j = 1, \dots, n)$$

Consider the algebraic variety  $M' \subset \mathbb{A}^n$  defined by the equations  $f_i(x) = 0$ , where  $i = 1, \dots, r$ .

**Problem 19.** There exists a neighbourhood  $U$  of  $x$  in the real topology of  $\mathbb{A}^n$  such that  $M' \cap U$  is a  $d$ -dimensional analytic subvariety of  $\mathbb{A}^n$  and  $M \cap U = M' \cap U$ .

The theorem is proved.  $\square$

Notice that if  $K = \mathbb{R}$  then  $M^{\text{reg}}$  is at the same time a real analytic subvariety of the complex analytic variety  $M^{\text{reg}}(\mathbb{C})$  and any of its tangent spaces is a real form of the tangent space of  $M^{\text{reg}}(\mathbb{C})$  at the same point.

**Problem 20 (Corollary).** Any  $d$ -dimensional algebraic variety  $M$  in a complex or real affine space  $\mathbb{A}^n$  is the union of a finite number of nonintersecting analytic subvarieties of  $\mathbb{A}^n$ , the maximal of their dimensions being equal to  $d$ .

Theorem 4 proved enables us to introduce a natural analytic structure on an arbitrary nonsingular complex algebraic variety.

**Theorem 5.** Any  $d$ -dimensional nonsingular complex algebraic variety possesses a unique structure of a  $d$ -dimensional complex analytic variety such that

- 1) all rational functions are analytic in their domains;
- 2) in an appropriate neighbourhood of any point a system of analytic coordinates may be chosen from the restrictions of rational functions.

**Problem 21.** The analytic structure on an embedded nonsingular affine complex algebraic variety defined as on an analytic subvariety of an affine space satisfies the conditions of Theorem 5.

**Problem 22.** Prove Theorem 5.

**Problem 23.** Any morphism of nonsingular complex algebraic varieties is an analytic map.

**Problem 24.** The analytic structure of the direct product of nonsingular complex algebraic varieties, coincides with the analytic structure of their direct product as of analytic varieties.

**5°. Realification of Complex Algebraic Varieties.** A complex analytic variety can be considered as a real analytic variety (of doubled dimension), and similarly a complex algebraic variety can be considered as a real algebraic variety. We confine ourselves to the construction of the realification functor for affine varieties.

First, let us agree to consider the  $n$ -dimensional complex affine space  $\mathbb{A}^n$  also as the  $2n$ -dimensional real affine space  $\mathbb{A}^{2n}(\mathbb{R})$  identifying  $(Z_1, \dots, Z_n) \in \mathbb{A}^n$  with  $(X_1, \dots, X_n, Y_1, \dots, Y_n) \in \mathbb{A}^{2n}(\mathbb{R})$ , where  $X_k + iY_k = Z_k$ .

Now let  $M$  be an algebraic variety in  $\mathbb{A}^n$ . Rewriting the equations which define it in real coordinates, it is easy to see that it is an algebraic variety in  $\mathbb{A}^{2n}(\mathbb{R})$ , too. The variety  $M$  determined in this way will be called a *realification* of  $M$  and denoted by  $M^{\mathbb{R}} = \text{Res}_{\mathbb{C}/\mathbb{R}} M$ .

Similarly, passing to real coordinates it is easy to see that any morphism of embedded complex affine varieties is at the same time a morphism of the corresponding real varieties. Therefore the realification makes sense independently of an embedding.

**Problem 25.**  $\dim M^{\mathbb{R}} = 2 \dim M$ .

Let us describe the polynomial algebra on  $M^{\mathbb{R}}$ . Let  $z_1, \dots, z_n$  be the restrictions onto  $M$  of coordinate functions on  $\mathbb{A}^n$ . By the definition  $\mathbb{R}[M^{\mathbb{R}}]$  is generated by the real and imaginary parts of these functions. Sometimes it is more convenient to consider the algebra  $\mathbb{C}[M^{\mathbb{R}}] = \mathbb{R}[M^{\mathbb{R}}] \otimes_{\mathbb{R}} \mathbb{C}$  of "complex polynomials" on  $M^{\mathbb{R}}$  that contains functions  $z_1, \dots, z_n$  themselves. The above implies that

$$\mathbb{C}[M^{\mathbb{R}}] = \mathbb{C}[z_1, \dots, z_n, \bar{z}_1, \dots, \bar{z}_n] \quad (5)$$

Therefore,  $\mathbb{C}[M^{\mathbb{R}}]$  is generated by  $\mathbb{C}[M] = \mathbb{C}[z_1, \dots, z_n]$  and  $\overline{\mathbb{C}[M]} = \mathbb{C}[\bar{z}_1, \dots, \bar{z}_n]$ .

This shows, in particular, that closed subsets of  $M^{\mathbb{R}}$  are the subsets defined by algebraic equations with respect to  $z_1, \dots, z_n$  and  $\bar{z}_1, \dots, \bar{z}_n$ . Considered as real algebraic varieties, they are called (*closed*) *real subvarieties* of  $M$ .

A map  $f: M \rightarrow N$  of complex affine varieties is an *antiholomorphic morphism* if  $f^* \mathbb{C}[N] \subset \overline{\mathbb{C}[M]}$ . Clearly, antiholomorphic morphisms, as well as genuine (holomorphic) morphisms, are morphisms of realified varieties.

**Problem 26.** Any antiholomorphic morphism is continuous in the complex Zariski topology.

**Problem 27.** Let  $M$  be a real affine variety. Then there exists a unique antiholomorphic automorphism  $x \mapsto \bar{x}$  (complex conjugation) of  $M(\mathbb{C})$  identical on  $M$ . Moreover, we have

$$M = \{x \in M(\mathbb{C}) : \bar{x} = x\}$$

and  $\bar{\bar{x}} = x$  for any  $x \in M(\mathbb{C})$ .

In conclusion notice that  $(M \times N)^{\mathbb{R}} = M^{\mathbb{R}} \times N^{\mathbb{R}}$  for any complex affine varieties  $M$  and  $N$ .

**6°. Forms of Vector Spaces and Algebras.** Let  $V$  be a vector space or algebra (not necessarily commutative or associative) over an arbitrary field  $K$  and  $k$  a subfield of  $K$ . One says that a  $k$ -subspace (resp.  $k$ -subalgebra)  $V_0 \subset V$  is a  *$k$ -form* of the space (resp. algebra)  $V$  if the identity embedding  $V_0 \subset V$  extends to an

isomorphism  $V_0 \otimes_k K \simeq V$ , i.e. a basis of  $V_0$  over  $k$  is a basis of  $V$  over  $K$ . A subspace  $U \subset V$  is *defined over  $k$*  (with respect to  $V_0$ ) if it is generated by vectors of  $V_0$ . In this case  $U_0 = U \cap V_0$  is a  $k$ -form of  $U$  and  $V_0/U_0$  is a  $k$ -form of  $V/U$ .

For instance  $k[X_1, \dots, X_n]$  is a  $k$ -form of  $K[X_1, \dots, X_n]$ . More generally, let  $M = M_0(K)$  be an affine variety over  $K$  obtained by a field extension from an affine variety  $M_0$  over  $k$ . Assuming  $M_0$  embedded in the  $n$ -dimensional affine space we deduce from Problem 1.14 that  $I(M) = KI(M_0)$  and therefore  $k[M_0] = k[X_1, \dots, X_n]/I(M_0)$  is a  $k$ -form of  $K[M] = K[X_1, \dots, X_n]/I(M)$ .

A linear map  $\varphi: U \rightarrow V$  of vector spaces with distinguished  $k$ -forms  $U_0, V_0$  is *defined over  $k$*  if  $\varphi(U_0) \subset V_0$ . Clearly, the kernel and the image of such a map are defined over  $k$ .

If  $K$  is the Galois extension of  $k$  then it is convenient to describe the  $k$ -forms in terms of the Galois group action. In particular, this is so in the only important for us case  $K = \mathbb{C}$ ,  $k = \mathbb{R}$  when the Galois group is generated by the complex conjugation. We will only consider this case and instead of “ $\mathbb{R}$ -form” we will say “*real form*”.

A real form  $V_0$  of a complex vector space (resp. algebra)  $V$  defines an involutive antilinear automorphism  $\tau$  of this space (resp. algebra)—the complex conjugation with respect to  $V_0$ —so that  $V_0 = \{v \in V: \tau(v) = v\}$ .

**Problem 28.** Conversely, let  $\tau$  be an involutive antilinear automorphism of a complex vector space (resp. algebra)  $V$ . Then the set  $V_0$  of the fixed points of  $\tau$  is a real form of the space (resp. algebra)  $V$ .

**Problem 29.** A subspace  $U \subset V$  is defined over  $\mathbb{R}$  if and only if  $\tau(U) = U$ .

**Problem 30.** A linear map of complex vector spaces with fixed real forms is defined over  $\mathbb{R}$  if and only if it commutes with the complex conjugation.

**7°. Real Forms of Complex Algebraic Varieties.** A *real form* of a complex affine variety  $M$  is its closed real subvariety  $M_0$  such that the identity embedding  $M_0 \subset M$  extends to an isomorphism

$$M_0(\mathbb{C}) \simeq M. \quad (6)$$

Therefore the passage to a real form of an algebraic variety is an operation inverse to the complexification. However, unlike the complexification and the realification, this operation is not uniquely defined and does not always exist.

The complex conjugation on  $M_0(\mathbb{C})$  is transported onto  $M$  via (6). The involutive antiholomorphic automorphism  $\tau$  of  $M$  obtained in this way is called the *complex conjugation (with respect to  $M_0$ )*. Clearly  $M_0 = \{x \in M: \tau(x) = x\}$ .

With certain reservations the converse statement, similar to Problem 28, holds.

**Theorem 6.** Let  $\tau$  be an involutive antiholomorphic automorphism of an *irreducible* complex affine variety  $M$ . If the set  $M_0$  of its fixed points contains at least one simple point then  $M_0$  is a real form of  $M$ .

*Proof.* For any  $f \in \mathbb{C}[M]$  set

$$f^\tau(x) = \overline{f(\tau(x))} \quad (x \in M).$$

The map  $f \mapsto f^\tau$  is an involutive antilinear automorphism of  $\mathbb{C}[M]$ . By Problem 28

$$\mathbb{C}[M]_0 = \{f \in \mathbb{C}[M]: f^\tau = f\},$$

is a real form of  $\mathbb{C}[M]$ . Let  $\mathbb{C}[M]_0 = \mathbb{R}[x_1, \dots, x_n]$  and let  $f_1, \dots, f_m \in \mathbb{R}[X_1, \dots, X_n]$  be generators of the ideal of relations between  $x_1, \dots, x_n$ . Suppose that  $M$  is embedded into the complex affine space  $\mathbb{A}^n$  so that  $x_1, \dots, x_n$  are the coordinate functions. Then  $\tau$  is just  $\mathbf{z}$  coordinate-wise complex conjugation and  $M_0$  is the set of real points of  $M$ . The ideal  $I(M)$  is generated by the polynomials  $f_1, \dots, f_m$ . By Theorem 3  $\text{rk} \frac{\partial(f_1, \dots, f_m)}{\partial(X_1, \dots, X_n)} \Big|_M = r = n - d$ , where  $d = \dim M$ .

Let  $x \in M_0$  be a simple point of  $M$ . Without loss of generality we may assume that  $\frac{D(f_1, \dots, f_r)}{D(X_1, \dots, X_r)} \neq 0$  at  $x$ . Then by Problem 19 there exists a neighbourhood  $U$  of  $x$  in a real topology of  $\mathbb{A}^n$  such that  $M \cap U$  is defined by the equations  $f_i(x) = 0, i = 1, \dots, r$ . On the other hand, if  $U$  is sufficiently small then the real solutions of these equations in  $U$  constitute a  $d$ -dimensional real analytic subvariety. Therefore  $\dim M_0 = \dim M_0(\mathbb{C}) = d$ . Since  $M_0(\mathbb{C}) \subset M$  and  $M$  is irreducible,  $M_0(\mathbb{C}) = M$  (Problem 5), as required.  $\square$

### Exercises

- 1) Any  $(n - 1)$ -dimensional irreducible algebraic variety in  $\mathbb{A}^n$  (resp. in  $\mathbb{P}^n$ ) can be defined by a single (resp. homogeneous) equation.
- 2) Any nontrivial (resp. homogeneous) equation defines in  $\mathbb{A}^n$  (resp. in  $\mathbb{P}^n$ ) a variety of dimension  $n - 1$ .
- 3) The line  $X_1 = 1, X_2 = 0$  in  $\mathbb{A}^3$  cannot be singled out of the surface  $X_1^2 + X_2X_3 = 1$  by a single equation.
- 4) Let  $f: M \rightarrow N$  be a dominant morphism of irreducible algebraic varieties. Then  $\dim N \leq \dim M$ .
- 5) If, under the conditions of Exercise 4,  $\dim N = \dim M$  then there exists a nonempty open subset  $N_0 \subset N$  such that any point of  $N_0$  has only a finite number of preimages.
- 6) In Theorem 2 it is impossible not to require irreducibility of  $N_k$ .
- 7)  $\mathbb{P}^n$  satisfies the ascending chain condition for irreducible quasiprojective algebraic varieties (see 2.6).
- 8) If  $\text{char } K = 0$  and an irreducible algebraic variety  $M \subset \mathbb{A}^n$  is singled out by the equations  $f_i(x) = 0$  for  $i = 1, \dots, m$ , then  $\text{rk } J \leq n - \dim M$  (see Theorem 3). Give an example (one can do it even for  $n = m = 1$ ) when  $\text{rk } J < n - \dim M$ .

- 9) The derivations  $\partial/\partial X_i$  constitute a basis of the space  $D(K(X_1, \dots, X_n), K(X_1, \dots, X_n))$ .
- 10) Let  $M \subset \mathbb{A}^2$  be defined by the equation  $X_1^2 + X_2^2 = 1$ . Find a basis of the space  $D(K(M), K(M))$ .
- 11) Under the notation of the proof of Theorem 4 the variety  $M$  is an irreducible component of the variety  $M'$ .
- 12) Under the notation of Theorem 4 let  $x$  be a simple point of  $M$ . For any tangent vector  $\xi \in T_x(M^{\text{reg}})$  put  $\partial_\xi$  for the derivation along  $\xi$ . Then the map  $\xi \mapsto \partial_\xi$  is an isomorphism of  $T_x(M)$  onto  $D_x(K[M], K)$ , where  $K = \mathbb{C}$  or  $\mathbb{R}$ . In Exercises 13–16 we assume  $\text{char } K = 0$ .
- 13) Let  $A$  and  $B$  be subalgebras of the field  $L$  that contains  $K$ , such that  $A \subset B$  and  $B$  is finitely generated over  $A$ . Then the restriction map  $D(B, L) \rightarrow D(A, L)$  is an epimorphism.
- 14) Let  $f: x \mapsto (f_1(x), \dots, f_m(x))$  be a morphism of an irreducible algebraic variety  $M$  into  $\mathbb{A}^m$ . Further, let  $\{\partial_1, \dots, \partial_k\}$  be a basis of the space  $D(K(M), K(M))$ . Consider the matrix  $(\partial_j f_i)$  with entries from  $K(M)$ . Suppose that  $\text{rk}(\partial_j f_i) = l$ . Then  $\dim f(M) = l$ .
- 15) If  $f_1, \dots, f_n \in K(X_1, \dots, X_n)$  are such that  $\frac{D(f_1, \dots, f_n)}{D(X_1, \dots, X_n)} \neq 0$  then these functions are algebraically independent.
- 16) Let  $M \subset \mathbb{A}^n$  be an irreducible algebraic variety and  $f \in K(\mathbb{A}^n)$ . If  $(\partial f/\partial X_i)|_M = 0$  for  $i = 1, \dots, n$ , then  $f|_M = \text{const}$ .  
The *Poincaré series* of a nonnegatively graded vector space  $V$  with finite dimensional grading subspaces  $V_k$  is the formal power series

$$P_V(t) = \sum_{k \geq 0} (\dim V_k) t^k.$$

Clearly, if  $U \subset V$  is a homogeneous subspace then

$$P_{V/U}(t) = P_V(t) - P_U(t).$$

If  $A$  is a graded algebra then a *graded  $A$ -module* is an  $A$ -module  $M$  graded as a vector space so that  $A_k M_l \subset M_{k+l}$  for any  $k, l \in \mathbb{Z}$ .

- 17) Let  $A = K[U_0, U_1, \dots, U_n]$  and  $M$  a finitely generated graded  $A$ -module. Then  $P_M(t) = p(t)/(1-t)^{k+1}$ , where  $p$  is a polynomial with integer coefficients and  $k \leq n$ . (Hint: prove by induction in  $n$  with the kernel of the multiplication by  $u_n$  considered as a graded  $K[U_0, U_1, \dots, U_{n-1}]$ -module).
- 18) Let  $p(t) = \sum_{k \geq 0} a_k t^k$  be a formal power series with rational coefficients. It may be presented in the form  $p(t) = p(t)/(1-t)^{d+1}$ , where  $p$  is a polynomial and  $p(1) \neq 0$ , if and only if  $a_k = f(k)$  for sufficiently large  $k$ , where  $f$  is a polynomial of degree  $d$ .
- 19) Let  $M \subset \mathbb{P}^n$  be a  $d$ -dimensional algebraic variety and  $A = K[M]^{\text{pr}}$ . Then  $p_A(t) = p(t)/(1-t)^{d+1}$ , where  $p$  is a polynomial with integer coefficients and  $p(1) \neq 0$ .

- 20) The same as in Exercise 19 but with  $K[M]^{\text{pr}}$  replaced by any graded algebra of the form  $K[U_0, U_1, \dots, U_n]/I$ , where  $I$  is a homogeneous ideal whose set of zeros is  $M$ .
- 21) Let  $M \subset \mathbb{P}^n$  be an irreducible algebraic variety and  $M_1 = \{x \in M : p(x) = 0\}$ , where  $p \in K[M]^{\text{pr}}$  is a nonzero homogeneous element. Then  $\dim M_1 = \dim M - 1$ .
- 22) The dimension of an irreducible algebraic variety equals  $d$  if and only if the maximum of the dimensions of its proper closed subvarieties equals  $d - 1$ .
- 23) Let  $M$  be an irreducible algebraic variety in a complex affine space and  $\bar{M}$  its complex conjugate. There is an isomorphism  $M^{\mathbb{R}}(\mathbb{C}) \simeq M \times \bar{M}$  which to any  $x \in M^{\mathbb{R}}$  assigns  $(x, \bar{x}) \in M \times \bar{M}$ .
- 24) Let  $M$  be an irreducible complex affine variety. Prove that  $(M^{\mathbb{R}})^{\text{reg}} = M^{\text{reg}}$ .

### Hints to Problems

2. Apply Problem 1.18.
3. Let  $B \subset A$  be a subalgebra generated by a given transcendence basis. It suffices to verify that if  $a \in A$ , where  $a \neq 0$ , then  $a^{-1} \in QA$  is algebraic over  $B$ . Let  $b_0 + b_1 a + \dots + b_m a^m = 0$ , where  $b_i \in B$  and  $b_0 \neq 0$ . Then  $a^{-1} = -b_0^{-1}(b_1 + b_2 a + \dots + b_m a^{m-1})$ , i.e.  $a^{-1} \in QB[a]$ . Next, apply Problem 1.14.
4. Reduce to the case when  $M$  and  $N$  are irreducible and  $M$  is an affine variety. Next, make use of the fact that if  $M$  is an irreducible affine variety then  $\dim M = \text{tr. deg } K[M]$ .
5. Reduce to the case when  $M$  is an affine variety. Then there is a homomorphism  $\sigma: K[M] \rightarrow K[N]$ . We must prove that its kernel is zero. Let  $\{f_1, \dots, f_k\}$  be a transcendence basis of  $K[N]$  and  $\bar{f}_i$ , where  $i = 1, \dots, k$ , are elements of  $K[M]$  such that  $\sigma(\bar{f}_i) = f_i$ . Then  $\{\bar{f}_1, \dots, \bar{f}_k\}$  is a transcendence basis of  $K[M]$ . Put  $A = K[\bar{f}_1, \dots, \bar{f}_k]$  and let  $f \in \text{Ker } \sigma$ , where  $f \neq 0$ . Then  $f$  is algebraic over  $A$ , i.e. there are  $a_0, a_1, \dots, a_m \in A$ , where  $a_0 \neq 0$ , such that  $a_0 + a_1 f + \dots + a_m f^m = 0$ . Applying  $\sigma$  to this equality we get  $\sigma(a_0) = 0$  which is impossible because of algebraic independence of  $f_1, \dots, f_k$ .
8. It suffices to put  $\partial(a/b) = (\partial(a)b - a\partial(b))/b^2$ .
9. Reduce to the case  $B = A[u]$ . If  $f$  is a minimal polynomial of  $u$  over  $A$  then  $f'(u) \neq 0$  and  $\partial u$  is determined from the linear equation  $f'(u)\partial u + f^\partial(u) = 0$ , where  $f^\partial$  is the polynomial obtained from  $f$  by applying  $\partial$  coefficient-wise.
10. Follows from Problems 7 and 9.
12. First prove that if  $\tilde{\partial}$  is a  $\pi$ -derivation of  $K[X_1, \dots, X_n]$  into  $K(M)$  which carries  $X_i$  into  $\lambda_i$  then

$$\tilde{\partial}(f) = \sum_{1 \leq i \leq n} \lambda_i \frac{\partial f}{\partial X_i} \Big|_M$$

for any polynomial  $f \in K[X_1, \dots, X_n]$ .

13. To each derivation  $\partial \in D_x(K[M], K)$  assign the derivation  $\tilde{\partial} = \partial \cdot \pi \in D_x(K[X_1, \dots, X_n], K)$ , where  $\pi$  is the restriction homomorphism onto  $M$ . The map  $\partial \mapsto \tilde{\partial}$  is an isomorphism of the space  $D_x(K[M], K)$  onto the space

of  $\varphi_x$ -derivations of  $K[X_1, \dots, X_n]$  into  $K$  that vanish on  $I(M)$ . The derivation  $\tilde{\delta} \in D_x(K[X_1, \dots, X_n], K)$  is defined by the numbers  $\lambda_i = \tilde{\delta}X_i$  and it vanishes on  $I(M)$  if and only if

$$\sum_j \lambda_j \frac{\partial f_i}{\partial X_j}(x) = 0 \quad \text{for } i = 1, \dots, m.$$

Hence, these derivations form the space of dimension  $n - \text{rk } J(x)$ .

14. Proved similarly to Problem 8.
16. By Problem 2.23 and Problem 15 the proof reduces to the affine case for which the statement follows from the first definition of a simple point.
17. Take  $M^{\text{reg}}$  to be one of the required subvarieties.
18. Consider the decomposition with respect to the last column of each minor of order  $r + 1$  of the matrix  $\frac{\partial(f_1, \dots, f_m)}{\partial(X_1, \dots, X_n)}$  bordering  $\Delta$ .
19. The implicit function theorem implies that in a neighbourhood  $U$  of the point  $x$  (in the real topology of  $\mathbb{A}^n$ ) the equations of the variety  $M'$  can be written in the form

$$X_i = \varphi_i(X_{r+1}, \dots, X_n) \quad \text{for } i = 1, \dots, r$$

where  $\varphi_i$  are smooth functions and the point  $(X_{r+1}, \dots, X_n)$  runs over an open (in the real topology) set  $V \subset \mathbb{A}^{n-r}$ . We may assume that  $\Delta \neq 0$  everywhere on  $U$  and  $V$  is pathwise connected. Let us prove that  $M' \cap U = M \cap U$ . Let  $x = (X_1^0, \dots, X_n^0)$ . Consider a smooth path  $X_i = X_i(t)$ , where  $i = r + 1, \dots, n$ , in  $V$  satisfying  $X_i(0) = X_i^0$ . The corresponding smooth path  $x(t)$  on  $M'$  satisfies  $x(0) = x$ . Problem 18 implies that along  $x(t)$  we have

$$\frac{df_i}{dt} = \sum_{1 \leq k \leq m} \psi_{ik}(t) f_k \quad \text{for } i = 1, \dots, m$$

where  $\psi_{ik}$  are certain smooth functions. Since  $f_i(x(0)) = 0$  for  $i = 1, \dots, m$ , then  $f_i(x(t)) = 0$  for any  $t$  i.e.  $x(t) \in M$ .

22. The uniqueness is obvious. It suffices to prove the existence for the affine varieties (cf. Problems 2.23 and 15) in which case it follows from Problem 21.
25. Compare the complex and the real analytic structure on  $M = M^{\mathbb{R}}$  described in Problem 20.
28. If  $V$  is considered as a real vector space then  $\tau$  is its involutive linear transformation. The space  $V$  decomposes over  $\mathbb{R}$  into the direct sum of eigensubspaces  $V_0$  and  $V_1$  of this transformation corresponding to the eigenvalues 1 and  $-1$  respectively. Since  $\tau$  is antilinear over  $\mathbb{C}$ , then  $V_1 = iV_0$ , hence,  $V_0$  is a real form of  $V$ .
29. See Problem 1.4.14.

## Chapter 3

### Algebraic Groups

The definition of an algebraic group is similar to that of a Lie group, except that differentiable manifolds are replaced by algebraic varieties and differentiable maps by morphisms of algebraic varieties. In this book we will only consider the algebraic groups whose underlying varieties are affine ones. They are called “affine” or “linear” algebraic groups. The difference between arbitrary groups and affine ones is quite essential from the point of view of algebraic geometry and almost indiscernible from the group-theoretical points of view, since the commutator group of any irreducible algebraic group is an affine algebraic group. Besides, the general linear groups and any of their algebraic subgroups are affine algebraic groups. Therefore the affine algebraic groups are the most interesting ones for the Lie group theory. We will simply call them algebraic groups.

In 1.4–3.7 of this chapter the ground field  $K$  is assumed to be algebraically closed.

#### § 1. Background

**1°. Main Definitions.** In this subsection the ground field  $K$  is an arbitrary infinite field. An *algebraic group* is a group  $G$  endowed with the structure of an affine algebraic variety so that the maps

$$\mu: G \times G \rightarrow G, \quad (x, y) \mapsto xy$$

$$l: G \rightarrow G, \quad x \mapsto x^{-1}$$

are morphisms of algebraic varieties.

The most important example of an algebraic group is the general linear group, i.e.  $GL_n(K)$  or, in another interpretation, the group  $GL(V)$ , where  $V$  is an  $n$ -dimensional vector space over  $K$ . Being a principal open subset in the vector space  $L_n(K)$ , the group  $GL_n(K)$  inherits the canonical structure of an affine variety (see 2.1.3). In this situation the rational functions in matrix elements whose denominators are powers of the determinant serve as polynomials on  $GL_n(K)$ . This implies that the multiplication and the inversion in  $GL_n(K)$  are morphisms of algebraic varieties, i.e.  $GL_n(K)$  is an algebraic group.

Similarly, the group of affine transformations of the  $n$ -dimensional affine space over  $K$  can be considered as an algebraic group.

Other important examples of algebraic groups are the *additive group of the field  $K$* , which we will denote also by  $K$ , and the *multiplicative group of  $K$* , which we will denote by  $K^*$ . The latter is, however, just  $GL_1(K)$ . The *direct product of algebraic groups* is the direct product of abstract groups endowed with the structure of an affine variety as the direct product of affine varieties (see 2.4.1). Clearly, the direct product of algebraic groups is an algebraic group.

The algebraic group  $K^n$  (the direct product of  $n$  copies of the additive group of  $K$ ) is called the  *$n$ -dimensional (algebraic) vector group*.

The definition of an algebraic group  $G$  implies that for any  $g \in G$  the left and the right translations

$$l(g): x \mapsto gx, \quad r(g): x \mapsto xg^{-1}$$

and also the inner automorphism  $a(g) = l(g)r(g)$  are automorphisms of the algebraic variety  $G$ .

Since left translations act transitively on  $G$ , all points of the variety  $G$  are on an equal footing.

**Theorem 1.** *Let  $G$  be an algebraic group. Put  $G^0$  for the irreducible component of  $G$  that contains the unit. Then  $G^0$  is a normal subgroup and other irreducible components of  $G$  are cosets with respect to  $G^0$ .*

**Problem 1.** Prove Theorem 1.

An *algebraic subgroup* of an algebraic group is a closed (in the Zariski topology) subgroup. Clearly, an algebraic subgroup is an algebraic group with respect to the same group operation and induced structure of the affine variety.

**Problem 2.** The closure of any subgroup of an algebraic group is an (algebraic) subgroup.

**Problem 3.** Any irreducible subgroup of an algebraic group is closed.

An algebraic subgroup of a general linear group is called an *algebraic linear group*. Let us emphasize that an *algebraic linear group* is *not* just an algebraic group but an algebraic group given in a linear representation (do not confuse this term with the term “linear algebraic group” which means in this text the same as just “algebraic group”!).

*Examples of algebraic linear groups.* 1) The group  $SL(V)$  of unimodular linear transformations. The polynomials on  $SL(V)$ , or any of its algebraic subgroups, are simply polynomials in matrix elements.

2) The groups  $O(V, f)$  ( $Sp(V, f)$ ) of linear transformations that preserve a non-degenerate (skew)symmetric bilinear form  $f$ .

3) The group

$$GL(V; U) = \{A \in GL(V): AU \subset U\},$$

where  $U$  is a subspace of a space  $V$ , and more generally, the group

$$\mathrm{GL}(V; U, W) = \{A \in \mathrm{GL}(V): (A - E)U \subset W\},$$

where  $U, W$  are subspaces of  $V$  such that  $W \subset U$ .

4) Any finite linear group.

**Problem 4.** Linear groups in the above examples are algebraic.

Let  $V_1, \dots, V_n$  be vector spaces. The algebraic group  $\mathrm{GL}(V_1) \times \cdots \times \mathrm{GL}(V_n)$  is naturally identified with an algebraic linear group in the space  $V = V_1 \oplus \cdots \oplus V_n$  consisting of all invertible linear transformations that preserve each of the subspaces  $V_1, \dots, V_n$ . In the basis of  $V$ , which is the union of bases of  $V_1, \dots, V_n$ , the elements of  $\mathrm{GL}(V_1) \times \cdots \times \mathrm{GL}(V_n)$  are presented by block-diagonal matrices. In particular,  $(K^*)^n \cong \mathrm{GL}_1(K) \times \cdots \times \mathrm{GL}_1(K)$  ( $n$  factors) can be presented as a group of invertible diagonal  $n \times n$  matrices.

A *homomorphism of algebraic groups* is a map which is a group homomorphism and at the same time a morphism of algebraic varieties. An *isomorphism* of algebraic groups is an invertible homomorphism, i.e. a map which is simultaneously an isomorphism of groups and of algebraic varieties.

Let  $f: G \rightarrow H$  be a homomorphism of algebraic groups and  $H_1 \subset H$  an algebraic subgroup. Clearly,  $f^{-1}(H_1)$  is an algebraic subgroup in  $G$ . In particular,  $\mathrm{Ker} f$  is a (normal) algebraic subgroup in  $G$ .

A *linear representation of an algebraic group* in a space  $V$  is its homomorphism into  $\mathrm{GL}(V)$ .

**Problem 5.** If  $R$  and  $S$  are linear representations of an algebraic group  $G$ , then the representations  $R + S, RS$  and  $R^*$  (see 1.1.4) are also its linear representations as of an algebraic group. (Cf. Problem 1.1.9).

In particular, this implies that the natural linear representation  $T_{k,l}$  of  $\mathrm{GL}(V)$  in the space of tensors of type  $(k, l)$  (see 1.1.4) is its linear representation as of an algebraic group.

The one-dimensional linear representations of an algebraic group  $G$  are called its *characters*. They constitute a group which will be denoted by  $\mathcal{X}(G)$ , cf. 1.1.4.

Let  $L$  be a field extension of  $K$ . For any algebraic group  $G$  over  $K$  we may consider the algebraic group  $G(L)$  over  $L$  whose variety is obtained from the variety  $G$  by a field extension, cf. 2.1.1 and 2.1.2, and the group operations are the morphisms extending the operations of  $G$ . The group  $G$  is a dense subgroup of  $G(L)$  as is shown in Problem 2.1.14.

## 2°. Complex and Real Algebraic Groups

**Problem 6.** Any complex algebraic group is a nonsingular algebraic variety.

Due to this fact any complex algebraic group possesses a canonical complex analytic manifold structure, cf. 2.3.4. Similarly, any real algebraic group possesses a canonical real analytic manifold structure. Since morphisms of nonsingular complex and real affine varieties are analytic, the following statement holds.

**Theorem 2.** Any complex (real) algebraic group is a complex (real) Lie group of the same dimension. Any algebraic subgroup of a complex or real algebraic group is its Lie subgroup.

However, not any Lie subgroup is an algebraic subgroup.

**Problem 7.** Subgroups  $\left\{ \exp t \begin{pmatrix} 1 & 0 \\ 0 & i \end{pmatrix} : t \in \mathbb{C} \right\}$  and  $\left\{ \exp t \begin{pmatrix} 1 & 1 \\ 0 & 1 \end{pmatrix} : t \in \mathbb{C} \right\}$  of  $\mathrm{GL}_2(\mathbb{C})$  are Lie subgroups but not algebraic subgroups.

Any homomorphism of complex or real algebraic groups is at the same time a Lie group homomorphism but not vice versa. If it is necessary to emphasize that we are speaking about an algebraic group homomorphism we will say “polynomial homomorphism”. We will also adopt the similar convention for linear representations.

**Problem 8.** Any complex algebraic group connected in the real topology is irreducible.

The converse is also true: see Theorem 3.1. Moreover, any irreducible complex algebraic variety is connected, see e.g. [53]

The realification of complex affine varieties (see 2.3.5) transforms any complex algebraic group  $G$  into a real algebraic group  $G^{\mathbb{R}}$  of the doubled dimension.

As an example, consider  $\mathrm{GL}_n(\mathbb{C})$ . The polynomial algebra on this group is generated by the matrix elements and the function  $A \mapsto (\det A)^{-1}$ . By 2.3.5 this implies that the algebraic subgroups of  $\mathrm{GL}_n(\mathbb{C})^{\mathbb{R}}$  (we will call them *real algebraic subgroups* of  $\mathrm{GL}_n(\mathbb{C})$ ) are the subgroups which can be determined by algebraic equations in the matrix elements and their complex conjugates.

For instance, the unitary group  $U_n$  is a real algebraic subgroup of  $\mathrm{GL}_n(\mathbb{C})$  and therefore a real algebraic group.

A real algebraic subgroup  $G_0$  is a *real form* of a complex algebraic group  $G$  if the identity embedding  $G_0 \subset G$  extends to an isomorphism  $G_0(\mathbb{C}) \simeq G$ .

**Problem 9.** Any subgroup  $G_0 \subset G$  which is a real form of a group variety  $G$  is a real form of the group  $G$ . The complex conjugation with respect to  $G_0$  is an automorphism of  $G$  as of an abstract group.

A map of complex algebraic groups which is a homomorphism of abstract groups and an antiholomorphic morphism of their group varieties is called an *antiholomorphic homomorphism*. By the above, the complex conjugation with respect to any real form  $G_0$  is an involutive antiholomorphic automorphism of the group  $G$ . For the irreducible groups the converse statement is also true.

**Problem 10.** The set of fixed points of any involutive antiholomorphic automorphism of an irreducible complex algebraic group is its real form.

For instance the subgroups  $\mathrm{GL}_n(\mathbb{R})$  and  $U_n$  are real forms of the group  $\mathrm{GL}_n(\mathbb{C})$  since they are the sets of fixed points of the involutive antiholomorphic automorphisms  $A \mapsto \bar{A}$  and  $A \mapsto (\bar{A}^t)^{-1}$ , respectively.

For the reducible groups the similar statement is false as the example of the complex conjugation in the group of cubic roots of unity shows.

**3°. Semidirect Products.** A *semidirect product of algebraic groups*  $G_1$  and  $G_2$  is defined as the semidirect product  $G_1 \rtimes_b G_2$  of abstract groups, cf. 1.1.11, endowed with the affine variety structure as the direct product of affine varieties. Here it is required that the map (1.1.7) be polynomial which ensures the polynomiality of the group operations.

Clearly, a semidirect product of complex or real algebraic groups is at the same time their semidirect product as of Lie groups.

Let an algebraic group  $G$  decompose into a semidirect product of its algebraic subgroups  $G_1$  and  $G_2$ , as an abstract group. Then the action  $b$  of  $G_2$  on  $G_1$  by conjugations is polynomial and we may form an algebraic group  $G_1 \rtimes_b G_2$ . Theorem 6 which will be proved in the following subsection shows that if the ground field  $K$  is algebraically closed and  $\text{char } K = 0$  then the abstract isomorphism  $G_1 \rtimes_b G_2 \simeq G$  defined by (1.1.6) is an algebraic group isomorphism.

If  $\text{char } K = p > 0$  this might be false. For instance in this case the algebraic group  $(K^*)^2 = \{(z_1, z_2) : z_1, z_2 \in K^*\}$  splits as an abstract group into the direct product of algebraic subgroups distinguished by the equations  $z_2 = 1$  and  $z_2 = z_1^p$  respectively. However,  $(K^*)^2$  is not the direct product of these subgroups as an algebraic group.

*Examples.* (cf. 1.1.11). 1) The group of affine transformations of a vector space  $V$  decomposes as an algebraic group into the semidirect product of the normal subgroup of parallel translations and  $\text{GL}(V)$ .

2) The group of invertible (upper) triangular  $n \times n$  matrices decomposes as an algebraic group into the semidirect product of the normal subgroup of untriangular matrices and the subgroup of invertible diagonal matrices.

**4°. Certain Theorems on Subgroups and Homomorphisms of Algebraic Groups.** Hereafter and till the end of §3 (subsection 3.8 excluded) the ground field  $K$  is assumed to be algebraically closed. This assumption is essential, in particular, for the subsequent theorems whose proof is based on the theorems on the image and the factorization of morphisms of algebraic varieties.

**Theorem 3.** *Let  $f: G \rightarrow H$  be an algebraic group homomorphism. Then  $f(G)$  is an algebraic subgroup of  $H$ .*

**Problem 11.** Prove this theorem.

**Theorem 4.** *The subgroup  $H$  of an algebraic group  $G$  generated by an arbitrary family  $\{M_\alpha | \alpha \in A\}$  ( $A$  is an index set) of irreducible subsets that contain the unit and are *épais* in their closures is an irreducible algebraic subgroup. In particular, the subgroup generated by an arbitrary family of irreducible algebraic subgroups is an irreducible algebraic subgroup.*

*Proof.* For any finite sequence  $(\varepsilon_1, \dots, \varepsilon_k)$ , where  $\varepsilon_i = \pm 1$ , consider the morphism ( $k$  factors)

$$\mu^{\varepsilon_1 \dots \varepsilon_k}: G \times \cdots \times G \rightarrow G, \quad (g_1, \dots, g_k) \mapsto g_1^{\varepsilon_1} \cdots g_k^{\varepsilon_k}.$$

The subgroup  $H$  is the union of the subsets of the form

$$M_{\alpha_1 \dots \alpha_k}^{\varepsilon_1 \dots \varepsilon_k} = \mu^{\varepsilon_1 \dots \varepsilon_k}(M_{\alpha_1} \times \cdots \times M_{\alpha_k}) \quad (\alpha_1, \dots, \alpha_k \in A).$$

Each of these subsets is irreducible and *épais* in its closure as the image of an irreducible subset which is *épais* in its closure, namely  $M_{\alpha_1} \times \cdots \times M_{\alpha_k} \subset G \times \cdots \times G$  ( $k$  factors), under the morphism  $\mu^{\varepsilon_1 \dots \varepsilon_k}$  (see Theorem 7 and Problems 2.1.13 and 2.1.14). Besides, since each of the subsets  $M_\alpha$  contains the unit,

$$M_{\alpha_1 \dots \alpha_k}^{\varepsilon_1 \dots \varepsilon_k} \cup M_{\alpha_{k+1} \dots \alpha_{k+1}}^{\varepsilon_{k+1} \dots \varepsilon_{k+1}} \subset M_{\alpha_1 \dots \alpha_{k+1}}^{\varepsilon_1 \dots \varepsilon_{k+1}}.$$

By Theorem 2.3.2 any non-decreasing chain consisting of the closures of  $M_{\alpha_1 \dots \alpha_k}^{\varepsilon_1 \dots \varepsilon_k}$  stabilizes. Hence, among all such closures there is one that contains all the others. Denote it by  $N$ . Clearly,  $\bar{H} = N$  and  $H$  is *épais* in  $N$ . By Problem 7 this implies that  $H = N$ .  $\square$

**Theorem 5.** *The commutator subgroup of an irreducible algebraic group is an irreducible algebraic subgroup.*

**Problem 12.** Prove Theorem 5.

Note that the similar theorem for Lie groups is false (see Exercise 1.4.4).

**Corollary.** *The commutator subgroup of an irreducible complex algebraic group is a Lie subgroup.*

**Problem 13.** Let  $G$  and  $H$  be irreducible algebraic groups and  $f: G \rightarrow H$  a map which is an abstract group homomorphism and coincides with a rational map  $f_0: G \rightarrow H$  on the latter's domain. Then  $f$  is a polynomial homomorphism.

**Theorem 6.** *A bijective homomorphism of algebraic groups over a field of zero characteristic is an isomorphism.*

**Problem 14.** Prove this theorem.

Over a field  $K$  of characteristic  $p > 0$  the similar theorem fails. A counterexample is given by the Frobenius endomorphism  $x \mapsto x^p$  of  $K$  (or  $K^*$ ).

**5°. Actions of Algebraic Groups.** An action of the algebraic group  $G$  on a quasiprojective algebraic variety  $M$  is a homomorphism  $\alpha$  of  $G$  into the group of automorphisms of  $M$  such that the map

$$G \times M \rightarrow M, \quad (g, x) \mapsto \alpha(g)x \tag{1}$$

is a morphism of algebraic varieties.

For example, any algebraic group acts in three ways on itself: by the action  $l$  by the left translations, the action  $r$  by the right translations and the action  $a$  by inner automorphisms. Any linear representation of an algebraic group may be considered as its action on the space of the representation.

When it is necessary to emphasize that we mean an action of an algebraic group and not of a Lie group or an abstract group we will use the term “an algebraic action”.

**Problem 15.** The natural action of  $GL(V)$  on the projective space  $P(V)$  is algebraic.

**Problem 16.** If an algebraic group  $G$  acts on a reducible quasiprojective variety  $M$ , then the elements of  $G^0$  transform each irreducible component of  $M$  into itself.

**Theorem 7.** Suppose  $\alpha$  is an action of an algebraic group  $G$  on a quasiprojective algebraic variety  $M$  and  $x \in M$ . Then

- 1) the stabilizer  $G_x$  is an algebraic subgroup of  $G$ ;
- 2) the orbit  $\alpha(G)x$  is a non-singular algebraic subvariety of  $M$ .

**Problem 17.** Prove Theorem 7.

**Corollary.** Under the conditions of the theorem  $G$  possesses at least one closed orbit on  $M$ .

*Proof.* The boundary of any orbit is invariant with respect to  $G$ . The dimension of the boundary is less than that of the orbit itself and therefore the boundary consists of orbits of lesser dimension. Therefore any orbit of the minimal dimension is closed.  $\square$

Clearly, any algebraic action of a complex algebraic group on a non-singular quasiprojective variety is also an action in the sense of Lie group theory, i.e. it is differentiable. In this situation the orbits are differentiable submanifolds due to the Theorem 7, which is in general false for arbitrary differentiable actions. (See Example in 1.1.6; its complexification gives a similar example for complex Lie groups).

The local closedness of orbits and closedness of images of homomorphisms stand in favour of the theory of algebraic groups as compared to the theory of Lie groups, where the phenomenon of dense winding of a torus, that does not deserve such an attention, required lengthy discussions. Confining ourselves to algebraic Lie groups and their algebraic actions we may get rid of various nuisances without substantially impoverishing the Lie group theory.

**6°. Existence of a Faithful Linear Representation.** In the theory of linear representations of compact topological groups one of the main methods is the study of the regular representation, i.e. the linear representation of the group in the space of functions on this group induced by its action on itself, say by right translations. This method turns out to be fruitful in the theory of algebraic groups as well. Making use of this method we will prove in this subsection the following

**Theorem 8.** Any algebraic group is isomorphic to an algebraic linear group.

First, consider the following general situation. Suppose  $\alpha$  is an action of any algebraic group  $G$  on an affine variety  $M$ . Put  $\alpha_*$  for the corresponding linear

representation of  $G$  in the space  $K[M]$  of polynomials on  $M$  defined by the formula

$$(\alpha_*(g)f)(x) = f(\alpha(g)^{-1}x). \quad (2)$$

This representation is infinite-dimensional (unless  $M$  consists of a finite number of points). However, we will see that it is the inductive limit of finite-dimensional representations.

By the definition of an algebraic action, the function

$$(g, x) \mapsto f(\alpha(g)^{-1}x) = f(\alpha(g^{-1})x)$$

is a polynomial on  $G \times M$  for any  $f \in K[M]$ . Since  $K[G \times M] = K[G] \otimes K[M]$  (see 2.1.4), there exist polynomials  $\varphi_i \in K[G]$ ,  $f_i \in K[M]$ , where  $i = 1, \dots, n$ , such that

$$f(\alpha(g)^{-1}x) = \sum_{1 \leq i \leq n} \varphi_i(g)f_i(x).$$

For a fixed  $g \in G$  we deduce that

$$\alpha_*(g)f = \sum_{1 \leq i \leq n} c_i f_i,$$

where  $c_i = \varphi_i(g) \in K$ . In other words, the orbit of a polynomial  $f$  under the action  $\alpha_*$  of  $G$  is contained in the finite-dimensional subspace  $\langle f_1, \dots, f_n \rangle \subset K[M]$ . Its linear span is a finite-dimensional invariant subspace containing  $f$ . Therefore, we have proved

**Theorem 9.** *For any action  $\alpha$  of  $G$  on an affine algebraic variety  $M$  the space  $K[M]$  is the union of finite-dimensional subspaces invariant with respect to  $\alpha_*(G)$ .*

**Problem 18.** Any finite-dimensional subrepresentation of  $\alpha_*$  is a polynomial one.

Now, let  $r$  be an action of an algebraic group  $G$  on itself by right translations. The corresponding linear representation  $r_*$  of  $G$  in the space  $K[M]$  defined by the formula

$$(r_*(g)f)(x) = f(xg) \quad (3)$$

is called the (*right*) *regular representation* of  $G$ .

Let  $V \subset K[G]$  be a finite dimensional subspace invariant with respect to  $r_*(G)$ . Denote by  $R$  the linear representation of  $G$  in the space  $V$  induced by  $r_*$ . By Theorem 3 the image  $H = R(G)$  of  $G$  under this representation is an algebraic subgroup of  $GL(V)$ . We will see that the space  $V$  may be chosen so that the map  $R: G \rightarrow H$  is an isomorphism of algebraic groups. The homomorphism  $R^*: K[H] \rightarrow K[G]$  is injective by the definition of  $H$  and its image is a subalgebra generated by the matrix elements of  $R$ .

**Problem 19.** The linear span of the matrix elements of  $R$  contains  $V$ .

If we take for  $V$  a subspace containing a system of generators of  $K[G]$ , then the homomorphism  $R^*: K[H] \rightarrow K[G]$  is an algebra isomorphism, hence the map  $R: G \rightarrow H$  is an isomorphism of algebraic groups. Therefore, Theorem 8 is proved.  $\square$

With this theorem we easily prove the following important statement: *the adjoint representation of a complex algebraic group  $G$  is polynomial.* Indeed, if  $G$  is realized as a linear group, then its adjoint representation is a subrepresentation of the linear representation  $T_{1,1}|_G$  whose polynomiality follows from Problem 5.

**7°. The Coset Variety and the Quotient Group.** Let  $G$  be an algebraic group,  $H$  its algebraic subgroup. It is natural to ask: how to introduce an algebraic variety structure on the coset space  $G/H$ ? The necessary requirement here is that the action of  $G$  on  $G/H$  be algebraic. When  $K$  is of zero characteristic this requirement already guarantees the uniqueness of the desired structure.

**Problem 20.** Let  $\text{char } K = 0$ . Suppose, that a quasiprojective algebraic variety structure is introduced on  $G/H$  so that the canonical action of  $G$  on  $G/H$  is an algebraic one. Then for any action  $\alpha$  of  $G$  on a quasiprojective variety  $M$  and any point  $x \in M$  satisfying  $G_x \supset H$  the map

$$\beta: G/H \rightarrow M, \quad gH \mapsto \alpha(g)x$$

is a morphism of algebraic varieties. If  $\beta$  is a bijection (i.e. if  $G_x = H$  and  $\alpha$  is transitive), then  $\beta$  is an isomorphism.

The existence of an algebraic structure on  $G/H$  is proved with the help of the following theorem.

**Theorem 10 (Chevalley's theorem).** *Let  $G$  be an algebraic group,  $H$  its algebraic subgroup. There exist a linear representation  $R: G \rightarrow \text{GL}(V)$  and a vector  $v_0 \in V$  such that  $H = \{h \in G: R(h)v_0 \in Kv_0\}$ . If  $H$  is a normal subgroup, then there exists a linear representation  $T$  of  $G$  such that  $H = \text{Ker } T$ .*

*Proof* of this theorem makes use of the regular representation  $r_*$  of  $G$ . Let  $I_G(H)$  be the ideal of  $K[G]$  consisting of all polynomials that vanish on  $H$ .

**Problem 21.**  $H = \{h \in G: r_*(h)I_G(H) \subset I_G(H)\}$ .

Choose a finite-dimensional subspace  $V \subset K[G]$  invariant with respect to  $r_*(G)$  and containing a system of generators of  $I_G(H)$ . Denote by  $W$  its intersection with  $I_G(H)$  and by  $S$  a (polynomial) linear representation of  $G$  in  $U$  induced by  $r_*$  (see Problem 18).

**Problem 22.**  $H = \{h \in G: S(h)W \subset W\}$ .

Let  $(f_1, \dots, f_m)$  be a basis of  $W$ . Put  $V = A^m U$ ,  $v_0 = f_1 \wedge \dots \wedge f_m$  and denote by  $R$  the linear representation of  $G$  in  $V$  induced by  $S$  (the subrepresentation of  $T_{m,0} \circ S$ ).

**Problem 23.**  $H = \{h \in G: R(h)v_0 \in Kv_0\}$ .

Thus, the first part of the theorem is proved. Now suppose that  $H$  is a normal subgroup. Denote by  $\chi_0$  the character of  $H$  defined from the identity

$$R(h)v_0 = \chi_0(h)v_0 \quad (h \in H)$$

By the definition (see 1.4.5)  $\chi_0$  is a weight of the representation  $R|_H$  and  $v_0$  the corresponding weight vector.

Let  $\chi_0, \chi_1, \dots, \chi_k$  be different characters of  $H$  constituting  $\{\chi^g: g \in G\}$ . By Problem 1.4.10 the sum  $\bigoplus_{0 \leq i \leq k} V_{\chi_i}(H) = V_1$  is invariant with respect to the representation  $R$  of  $G$  and the operators of the representation transitively permute its summands. (In particular, if  $G$  is irreducible the sum contains only one summand, i.e. the space  $V_{\chi_0}(H)$  is already invariant with respect to  $R(G)$ .)

Consider the restriction  $T$  of the natural linear representation of  $G$  in  $L(V_1)$  onto the invariant subspace  $\bigoplus_{0 \leq i \leq k} L(V_{\chi_i}(H)) = L_0(V_1)$ .

**Problem 24.**  $H = \text{Ker } T$ .

The Theorem is proved.  $\square$

Returning to the problem of defining an algebraic variety structure on  $G/H$  we can, under the notation of Theorem 10, identify  $G/H$  with the orbit  $O$  of the point  $Kv_0 \in P(V)$  under the natural  $G$ -action in the projective space  $P(V)$  defined by the representation  $R$ . By Theorem 7 it is an (embedded) quasiprojective variety. The  $G$ -action on  $G/H$  by left translations coincides with the restriction onto  $O$  of the natural  $G$ -action in the space  $P(V)$ , hence, it is algebraic.

Similarly, if  $H$  is a normal subgroup, then we can, under the notation of Theorem 10, identify  $G/H$  with the group  $T(G)$  which is, due to Theorem 3, an algebraic linear group.

These results combined with Problem 21 yield the following theorem.

**Theorem 11.** *Let  $\text{char } K = 0$  and  $G$  an algebraic group,  $H$  its algebraic subgroup. Then, on  $G/H$ , there is a unique quasiprojective algebraic variety structure for which the canonical  $G$ -action on  $G/H$  is algebraic. If, in addition,  $H$  is normal, then  $G/H$  is an affine variety and the quotient group  $G/H$  is algebraic.*

The reader has probably noticed the difference of our approaches to the definition of coset varieties for algebraic groups and coset manifolds for Lie groups. In fact we might base the definition of an algebraic structure on cosets for an algebraic group on the notion of factorization as we had done for Lie groups.

A map  $p: M \rightarrow N$  of algebraic varieties is called a *quotient map* if

- 1) a subset  $U \subset N$  is open if and only if  $p^{-1}(U)$  is open in  $M$ ;
- 2) a function  $f$  defined on an open subset  $U \subset N$  belongs to  $O_N(U)$  if and only if  $p^*f \in O_M(p^{-1}(U))$ .

For the proof of the following theorem see e.g. [10]

**Theorem 12.** *Let  $G$  be an algebraic group and  $H$  an algebraic subgroup. Then there exists a unique quasiprojective algebraic variety structure on  $G/H$  for which*

the canonical map  $p: G \rightarrow G/H$  is a quotient map. With respect to this structure the canonical  $G$ -action on  $G/H$  is algebraic and if  $H$  is normal then  $G/H$  is an algebraic group.

### Exercises

- 1) In the definition of an algebraic group the requirement on the inversion to be a morphism is redundant. (Hint: analyze the proof of Theorem 8.)
- 2) The automorphism group of an arbitrary finite-dimensional algebra is an algebraic linear group.
- 3) If  $M$  and  $N$  are *épais* subsets of an irreducible algebraic group  $G$  then  $MN = G$ .  
In exercises 4–6 the ground field  $K$  should be assumed algebraically closed.
- 4) Under the conditions of Theorem 4 there exist  $\alpha_1, \dots, \alpha_k$  and  $\varepsilon_1, \dots, \varepsilon_k = \pm 1$  such that  $H = M_{\alpha_1}^{\varepsilon_1} \dots M_{\alpha_k}^{\varepsilon_k}$ .
- 5) Give an example which shows that the irreducibility of  $M_\alpha$ 's in Theorem 4 is essential for the algebraicity of  $H$ .
- 6) The commutator group of any (not necessarily irreducible) algebraic group  $G$  is its algebraic subgroup. (Hint: first prove using Theorem 4 that  $(G, G^0)$  is an algebraic subgroup; then make use of the theorem that if the center of a group is of finite index then its commutator group is finite.)
- 7) Any connected real algebraic group is irreducible.
- 8) Give an example of an irreducible real algebraic group which is not connected.
- 9) Let  $G \subset \mathrm{GL}_n(\mathbb{C})$  be an irreducible complex algebraic group,  $\bar{G}$  its complex conjugate. The map  $G^{\mathbb{R}}(\mathbb{C}) \simeq G \times \bar{G}$  which to any  $A \in G^{\mathbb{R}}$  assigns  $(A, \bar{A})$  is an isomorphism.
- 10) The set of fixed points of an action of an algebraic group  $G$  on a quasi-projective variety  $M$  is closed in  $M$ .
- 11) The kernel of an action of an algebraic group  $G$  on a quasiprojective variety  $M$  is a (normal) algebraic subgroup of  $G$ .
- 12) For any action of an algebraic group  $G$  on an affine variety  $M$  there exists an embedding of  $M$  in a vector space  $V$  such that the action is induced by a linear representation of  $G$  in  $V$ . (Hint: for  $V$  take the vector space dual to a finite-dimensional  $G$ -invariant subspace of  $K[M]$  that contains a system of generators of this algebra).
- 13) Reproducing the proof of Theorem 8 construct a faithful linear representation of the additive group of the field.
- 14) Let  $H$  be an algebraic subgroup of a complex algebraic group  $G$  such that the quotient space  $G/H$  is compact in the real topology. Then  $G/H$  is a projective algebraic variety.

### Hints to Problems

1. Make use of the fact that transformations of the form  $l(g)$ ,  $r(g)$  and  $a(g)$ , where  $g \in G$ , being automorphisms of the group variety, can only permute its irreducible components.

3. Proof is similar to that of Problem 1.1.7.
6. Follows from the fact that all the points of a group variety are on equal footing.
7. If  $A$  is one of the matrices  $\begin{pmatrix} 1 & 0 \\ 0 & i \end{pmatrix}, \begin{pmatrix} 1 & 1 \\ 0 & 1 \end{pmatrix}$ , then the map  $\mathbb{C} \rightarrow GL_2(\mathbb{C})$ ,  $t \mapsto \exp tA$ , is a proper one (i.e. the preimage of any compact is compact itself). This implies that these subgroups are Lie subgroups. The first of them is contained in the algebraic subgroup of diagonal matrices but is not algebraic itself since there is no nonzero polynomial  $f$  of two variables (the diagonal elements of the matrices) such that  $f(e^t, e^{it}) = 0$  for all  $t \in \mathbb{C}$ . The proof of the fact that the other subgroup is not algebraic is similar.
9. Proof is deduced from the continuity of the group operations and the complex conjugation and from the density of  $G_0$  in  $G$ .
10. Follows from Theorem 2.3.6.
11. For an irreducible  $G$  follows from Theorem 2.1.5 and Problem 7.
12. Apply Theorem 4 to the set  $M$  of all commutators of elements of  $G$ .
13. For any  $g \in G$  the diagram of rational maps

$$\begin{array}{ccc}
 G & \xrightarrow{f_0} & H \\
 \downarrow l(g) & & \downarrow l(f(g)) \\
 G & \xrightarrow{f_0} & H
 \end{array}$$

commutes. From here we deduce that  $f_0$  is defined everywhere, hence  $f_0$  is polynomial (see Problem 2.1.29).

14. For irreducible groups this follows from Theorem 2.1.8 and Problem 13. In general case it is necessary to make use of Problem 2.2.14.
17. The orbit  $\alpha(G)x$  is the image of  $G$  under the morphism

$$\alpha^x: G \rightarrow M, \quad g \mapsto \alpha(g)x.$$

We may assume that  $G$  is irreducible. Theorem 2.2.2 implies then that the orbit is *épais* in its closure but, since all its points are on equal footing, it is open in its closure, i.e. is an algebraic subvariety of  $M$ . The same ("equality of rights" of points) considerations show that this subvariety is non-singular.

18. Let  $(f_1, \dots, f_n)$  be a basis of a  $G$ -invariant subspace  $V \subset K[M]$ . Then the definition of an algebraic action implies that

$$f_j(\alpha(g)^{-1}x) = \sum_i a_{ij}(g)f_i(x) \quad (g \in G, x \in M),$$

where  $a_{ij} \in K[G]$ .

19. Let  $(f_1, \dots, f_n)$  be a basis of  $V$ . Then

$$f_j(xg) = \sum_i a_{ij}(g)f_i(x),$$

where  $a_{ij}$  are the matrix elements of the representation  $R$ . Substituting  $x = e$  we find that  $f_j = \sum_i c_i a_{ij}$ , where  $c_i = f_i(e)$ .

20. For an irreducible group  $G$  it follows from Theorem 2.2.3 and the homogeneity (equal rights of points) considerations. For a reducible group  $G$  it is necessary to make use of Problem 2.2.14.
21.  $r(h)H \subset H \Leftrightarrow r_*(h)I_G(H) \subset I_G(H)$ .
23. Follows from the fact that a subspace is uniquely determined by the exterior product of its basics' vectors (see Problem 2.2.33).
24. Follows from the fact that the centralizer of  $L_0(V_1)$  in  $L(V_1)$  consists of operators acting as scalars on each of  $V_{x_i}(H)$ .

## §2. Commutative and Solvable Algebraic Groups

In this section, except 1°, we assume that  $\text{char } K = 0$ .

**1°. The Jordan Decomposition of a Linear Operator.** Let  $V$  be a finite-dimensional vector space. For any linear operator  $A \in L(V)$  and  $\lambda \in K$  consider the *eigenspace*

$$V_\lambda(A) = \{v \in V : (A - \lambda E)v = 0\}$$

and ambient *root subspace*

$$V^\lambda(A) = \{v \in V : (A - \lambda E)^m v = 0 \text{ for some } m\}$$

The subspaces  $V_\lambda(A)$  and  $V^\lambda(A)$  are invariant with respect to any linear operator commuting with  $A$ . As it is known,

$$V = \bigoplus_\lambda V^\lambda(A).$$

A linear operator  $A \in L(V)$  is called *semisimple* if it satisfies any of the following equivalent conditions:

- 1) in some basis  $A$  is expressed by a diagonal matrix;
- 2)  $V = \bigoplus_\lambda V_\lambda(A)$ ;
- 3)  $V^\lambda(A) = V_\lambda(A)$  for any  $\lambda \in K$ .

**Problem 1.** Let  $A \in L(V)$  be a semisimple linear operator and  $U \subset V$  a subspace invariant with respect to  $A$ . Then

- 1)  $A|_U$  is semisimple;
- 2) there exists an invariant subspace complementary to  $U$ .

**Problem 2.** Any family of commuting semisimple linear operators can be simultaneously reduced to the diagonal form.

In particular, this implies that the *sum and the product of commuting semisimple operators are semisimple operators.*

A linear operator  $A \in L(V)$  is called *nilpotent* (resp. *unipotent*) if  $A^m = 0$  (resp.  $(A - E)^m = 0$ ) for some  $m$ . This is equivalent to the fact that  $A^n = 0$  (resp.  $(A - E)^n = 0$ ), where  $n = \dim V$ .

Clearly, the *sum of commuting nilpotent operators is a nilpotent operator. The product of commuting unipotent operators is a unipotent operator.*

If  $A$  is both semisimple and nilpotent (resp. unipotent) then  $A = 0$  (resp.  $A = E$ ).

Let  $A \in L(V)$  be an arbitrary linear operator. The semisimple operator  $A_s$  defined by the condition

$$V_\lambda(A_s) = V^\lambda(A) \quad \text{for any } \lambda \in K$$

i.e. acting on each root subspace  $V^\lambda(A)$  of  $A$  as multiplication by  $\lambda$ , is called the *semisimple part* of  $A$ . The definition of root subspaces implies that  $A_n = A - A_s$  is nilpotent; it is called the *nilpotent part* of  $A$ . If  $A$  is invertible then  $A_u = AA_s^{-1} = E + A_nA_s^{-1}$  is unipotent; it is called the *unipotent part* of  $A$ . The operators  $A_s$ ,  $A_n$  and  $A_u$  commute with each other and with any operator commuting with  $A$ .

The decomposition  $A = A_s + A_n$  (resp.  $A = A_sA_u$ ) is called the *additive* (resp. *multiplicative*) *Jordan decomposition* of  $A$ . The following problem gives its axiomatic characterization.

**Problem 3.** The additive (resp. multiplicative) Jordan decomposition of a linear operator  $A$  is its unique decomposition into the sum (resp. product) of commuting semisimple and nilpotent (resp. unipotent) linear operators.

**2°. Commutative Unipotent Algebraic Linear Groups.** Let  $X$  be a nilpotent operator. For any formal power series

$$f(x) = \sum_{k \geq 0} a_k x^k \quad (a_k \in K)$$

set

$$f(X) = \sum_{k \geq 0} a_k X^k$$

(this sum is finite, actually). Clearly,

- 1)  $f(X) - a_0 E$  is nilpotent;
- 2)  $f(AXA^{-1}) = Af(X)A^{-1}$  for any invertible linear operator  $A$ .

In particular, set

$$\exp X = \sum_{k \geq 0} \frac{1}{k!} X^k,$$

$$\log(E + X) = \sum_{k \geq 1} \frac{(-1)^{k-1}}{k} X^k.$$

Since any unipotent operator is of the form  $E + X$ , where  $X$  is a nilpotent operator, the (nilpotent) operator  $\log A$  is defined for any unipotent  $A$ .

Let  $L_n(V)$  (resp.  $L_u(V)$ ) be the set of all nilpotent (resp. unipotent) operators in  $V$ . Clearly,  $L_n(V)$  and  $L_u(V)$  are algebraic varieties in  $L(V)$ .

**Problem 4.** The maps

$$\exp: L_n(V) \rightarrow L_u(V), \quad \log: L_u(V) \rightarrow L_n(V)$$

are morphisms inverse to each other.

**Problem 5.** 1) If nilpotent operators  $X, Y$  commute then

$$\exp(X + Y) = \exp X \cdot \exp Y.$$

2) If unipotent operators  $A, B$  commute then

$$\log AB = \log A + \log B$$

**Theorem 1.** *The minimal algebraic linear group  $G(A)$  containing a unipotent linear operator  $A$  consists of all (unipotent) linear operators of the form*

$$A^t = \exp(t \log A) \quad (t \in K)$$

and

$$K \rightarrow G(A), \quad t \mapsto A^t,$$

is an algebraic group isomorphism provided  $A \neq E$ .

**Problem 6.** Prove this theorem.

**Corollary 1.** *Any invertible linear operator  $A$  of finite order, i.e. such that  $A^m = E$  for some positive integer  $m$ , is semisimple.*

*Proof.* We have  $A^m = A_s^m A_u^m = E$  implying  $A_u^m = E$ , but due to Theorem 1 it is only possible if  $A_u = E$ .  $\square$

An algebraic linear group is called *unipotent* if all its operators are unipotent.

**Corollary 2.** Any unipotent algebraic linear group  $G$  is irreducible.

*Proof.* For any  $A \in G$  the subgroup  $G(A) \subset G$  is irreducible by Theorem 1. Therefore  $A \in G(A) \subset G^0$ .  $\square$

Problems 4 and 5 and Theorem 1 imply the following description of commutative unipotent groups.

**Theorem 2.** *Let  $G \subset GL(V)$  be a commutative unipotent algebraic linear group. Then  $\mathfrak{g} = \log G \subset L(V)$  is a subspace consisting of commuting nilpotent linear*

operators and  $\exp: \mathfrak{g} \rightarrow G$  is an isomorphism of the vector group  $\mathfrak{g}$  onto  $G$ . Conversely, if  $\mathfrak{g} \subset L(V)$  is a subspace consisting of commuting nilpotent linear operators then  $G = \exp \mathfrak{g} \subset GL(V)$  is a commutative unipotent algebraic linear group.

A similar description can be obtained for arbitrary unipotent groups the difference being that  $\exp$  is an isomorphism of not algebraic groups but only of algebraic varieties. In 3.6 we will give such a description for  $K = \mathbb{C}$  and see that  $\mathfrak{g} = \log G$  is nothing but the tangent algebra of  $G$ .

**3°. Algebraic Tori and Quasitori.** An algebraic group isomorphic to the direct product of  $n$  copies of  $K^*$  is called the  $n$ -dimensional algebraic torus. The adjective "algebraic" is applied here to distinguish algebraic tori from the tori in the sense of Lie group theory. In the context of the algebraic group theory over an algebraically closed field we will usually skip this adjective.

Together with the tori it is useful to consider algebraic groups which are direct products of a torus and a commutative finite group; we will call them (*algebraic*) quasitori. Note that irreducible quasitori are just tori.

**Problem 7.** In any quasitorus the elements of finite order form a dense subset.

**Theorem 3.** Under any linear representation of a quasitorus its elements are mapped into semisimple operators which are simultaneously diagonalizable.

*Proof.* If we confine ourselves to the elements of finite order then the statement of the theorem follows from Corollary of Theorem 1 and Problem 2; but Problem 7 implies that the basis which diagonalizes operators corresponding to elements of finite order also diagonalizes all the operators of the representation.

This theorem means that any linear representation of a quasitorus is a sum of one-dimensional representations. Now describe one-dimensional representations, or *characters*, of tori.

**Theorem 4.** Any character  $\chi$  of the torus  $(K^*)^n$  is of the form

$$\chi(x_1, \dots, x_n) = x_1^{k_1} \dots x_n^{k_n}, \quad \text{where } k_1, \dots, k_n \in \mathbb{Z}.$$

**Problem 8.** Prove this theorem.

Let  $T$  be an  $n$ -dimensional algebraic torus.

**Problem 9.** The characters of  $T$  form a basis of  $K[T]$  (as of vector space over  $K$ ).

Let  $\mathcal{X}(T)$  be the character group of  $T$ . Theorem 4 implies that this is a free commutative group of rank  $n$ . A duality between  $T$  and  $\mathcal{X}(T)$  holds, see Exercise 4. One of the manifestations of this duality is that a representation of  $T$  in the form of the direct product of  $n$  copies of  $K^*$  is equivalent to the choice of a basis of  $\mathcal{X}(T)$ . More precisely the following statement holds.

**Problem 10.** Let  $(\varepsilon_1, \dots, \varepsilon_n)$  be a basis of  $\mathcal{X}(T)$ . Then the map

$$\varepsilon: T \rightarrow (K^*)^n, \quad x \mapsto (\varepsilon_1(x), \dots, \varepsilon_n(x)),$$

is an isomorphism. Any isomorphism  $\varepsilon: T \simeq (K^*)^n$  is obtained in this way.

Another manifestation of the mentioned duality is the following description of the algebraic subgroups of  $T$ .

**Theorem 5.** *There is a one-to-one correspondence between algebraic subgroups of an  $n$ -dimensional torus  $T$  and subgroups of  $\mathcal{X}(T)$ , which to a subgroup  $\Gamma \subset \mathcal{X}(T)$  assigns the subgroup*

$$T^\Gamma = \{x \in T: \chi(x) = 1 \text{ for all } \chi \in \Gamma\} \subset T.$$

Let  $c_1, \dots, c_m$  ( $m \leq n$ ) be nonzero invariant factors of  $\Gamma$  (as of a subgroup of the free commutative group  $\mathcal{X}(T)$ ). There exists an isomorphism  $\varepsilon: T \simeq (K^*)^n$  such that

$$\varepsilon(T^\Gamma) = \{(x_1, \dots, x_n) \in (K^*)^n: x_1^{c_1} = \dots = x_m^{c_m} = 1\} \quad (1)$$

*Proof.* Let  $S \subset T$  be an algebraic subgroup. By Chevalley's theorem (Theorem 1.10) there exists a linear representation of  $T$  whose kernel is  $S$ . Let  $\chi_1, \dots, \chi_q$  be the weights of this representation. Then

$$S = \{x \in T: \chi_1(x) = \dots = \chi_q(x) = 1\} = T^\Gamma,$$

where  $\Gamma \subset \mathcal{X}(T)$  is a subgroup generated by  $\chi_1, \dots, \chi_q$ .

Further, let  $\Gamma \subset \mathcal{X}(T)$  be any subgroup and  $c_1, \dots, c_m$  ( $m \leq n$ ) its nonzero invariant factors. There exists a basis  $(\varepsilon_1, \dots, \varepsilon_n)$  of  $\mathcal{X}(T)$  such that  $\Gamma = \langle c_1 \varepsilon_1, \dots, c_m \varepsilon_m \rangle$ . We have

$$T^\Gamma = \{x \in T: \varepsilon_1(x)^{c_1} = \dots = \varepsilon_m(x)^{c_m} = 1\}$$

and if  $\varepsilon: T \simeq (K^*)^n$  is an isomorphism corresponding to the basis  $(\varepsilon_1, \dots, \varepsilon_n)$  then the subgroup  $\varepsilon(T^\Gamma)$  is singled out in  $(K^*)^n$  exactly by (1).

To complete the proof of the theorem it remains to show that  $\Gamma$  consists of all characters whose value on  $T^\Gamma$  is 1. Let  $\chi = k_1 \varepsilon_1 + \dots + k_n \varepsilon_n$  be such a character. Considering the values of  $\chi$  on the elements  $x \in T^\Gamma$  all the coordinates  $\varepsilon_1(x), \dots, \varepsilon_n(x)$  of which except one are equal to 1 we easily deduce from the above description that  $k_{m+1} = \dots = k_n = 0$ , while  $k_1, \dots, k_m$  are divisible by  $c_1, \dots, c_m$  respectively. But this means that  $\chi \in \Gamma$ .  $\square$

**Corollary.** *Any algebraic subgroup of a torus is a quasitorus.*

Notice two more corollaries of Theorem 5.

**Problem 11.** The character group of a torus is generated by weights of any faithful linear representation.

**Problem 12.** Any torus has elements which are not contained in any of its proper algebraic subgroups.

**4°. The Jordan Decomposition in an Algebraic Group.** In this subsection we will prove the following theorems:

**Theorem 6.** *An algebraic linear group  $G \subset GL(V)$  contains together with any linear operator  $A$  the operators  $A_s$  and  $A_u$ .*

**Theorem 7.** *Let  $R: G \rightarrow GL(U)$  be a linear representation of an algebraic group  $G$ . If  $A \in G$  is semisimple (resp. unipotent) then so is  $R(A)$ .*

In general terms the reason why this is true might be explained as follows:

1) the semisimple elements of an algebraic linear group are linked to its algebraic subgroups isomorphic to  $K^*$  or to its finite subgroups and the unipotent elements are linked to the subgroups isomorphic to  $K$ ;

2) the groups  $K^*$  and  $K$  do not admit nontrivial homomorphisms into each other and thanks to this they do not "intermix".

*Proof of Theorem 6.* For any linear operator  $A \in GL(V)$  denote by  $G(A)$  the smallest algebraic linear group containing  $A$ , i.e. the closure of the cyclic linear group generated by  $A$ .

If  $A$  is unipotent then by Theorem 1  $G(A)$  consists of unipotent operators and is isomorphic to  $K$  except for the trivial case  $A = E$ .

**Problem 13.** If  $A$  is semisimple then  $G(A)$  consists of semisimple operators and is a quasitorus.

In general,  $G(A)$  is contained in the smallest algebraic linear group  $G(A_s, A_u)$  containing  $A_s$  and  $A_u$ . The continuity considerations imply that  $G(A_s, A_u)$  is commutative. Since  $G(A_s)$  consists of semisimple elements and  $G(A_u)$  of unipotent ones, we have  $G(A_s) \cap G(A_u) = \{E\}$ . It follows,

$$G(A) \subset G(A_s, A_u) = G(A_s) \times G(A_u). \tag{2}$$

**Problem 14.** A quasitorus does not admit nontrivial homomorphisms into  $K$ .

**Problem 15.**  $G(A) = G(A_s) \times G(A_u)$ .

This immediately implies Theorem 6.  $\square$

*Proof of Theorem 7.* First, note that for any  $A \in G$  we have  $G(A) \subset G$  and  $R(G(A)) = G(R(A))$ .

If  $A \in G$  is semisimple then  $G(A)$  is a quasitorus. Applying Theorem 3 to  $R|_{G(A)}$  we see that  $R(A)$  is semisimple.

Now let  $A \in G$  be unipotent. Set  $B = R(A)$ . Suppose that  $B \neq E$ , otherwise we have nothing to prove. Then  $G(A) \simeq K$  and  $G(B) = R(G(A)) \simeq K$ . By Problem 15 we have

$$G(B) = G(B_s) \times G(B_u),$$

but since  $G(B)$  does not contain elements of finite order different from the unit,  $G(B) = G(B_u)$ , i.e.  $B$  is unipotent.  $\square$

An element  $g$  of an algebraic group  $G$  is *semisimple (unipotent)* if for some faithful (and therefore for any) linear representation  $R$  of  $G$  the operator  $R(g)$  is semisimple (unipotent).

Theorem 6 implies that any element  $g$  of an algebraic group  $G$  presents as the product of commuting semisimple and unipotent elements  $g_s, g_u \in G$ . By Problem 3 this decomposition is unique. The elements  $g_s$  and  $g_u$  are called *semisimple* and *unipotent parts* of  $g$  respectively and  $g = g_s g_u$  the *Jordan decomposition* of  $g$ .

Theorem 7 implies that any algebraic group homomorphism transforms the semisimple elements into semisimple ones and the unipotent elements into unipotent ones.

**Problem 16.** Let  $f: G \rightarrow H$  be an algebraic group homomorphism. For any semisimple (unipotent) element  $h \in f(G)$  its pre-image  $f^{-1}(h)$  contains a semisimple (unipotent) element.

Notice that the group  $K^*$  and, more general, any quasitorus consists only of semisimple elements (Theorem 3). Conversely, the group  $K$  and, therefore, any vector group consists of unipotent elements only.

An algebraic group all elements of which are unipotent is called *unipotent*. By Corollary 2 of Theorem 2 any unipotent algebraic group is irreducible.

### 5°. The Structure of Commutative Algebraic Groups

**Problem 17.** Any commutative algebraic group consisting of semisimple elements is a quasitorus.

Since the converse is true, this problem gives a convenient characterizations of quasitori (and therefore tori).

**Theorem 8.** Any commutative algebraic group is a direct product of a quasitorus and a vector group.

**Problem 18.** Prove this theorem.

**Corollary.** Any irreducible commutative algebraic group is the direct product of a torus and a vector group.

**6°. Borel's Theorem.** An algebraic group is called *solvable* if it is solvable as an abstract group. An example of a solvable algebraic group is the group  $B_n(K)$  of invertible (upper) triangular  $n \times n$  matrices over  $K$  (see Example 1.4.4; the arguments given there work for any field).

For solvable algebraic groups an analogue of Lie's theorem (see 1.4.5) holds. It can be proved in almost exactly the same way as Lie's theorem but we will deduce it from a more general theorem whose proof is in a sense even simpler.

The statement of Lie's theorem may be formulated as a fixed point theorem for an action of the considered group in the projective space associated with the space of the representation. Therefore Lie's theorem for algebraic groups is a consequence of the following theorem.

**Theorem 9** (Borel's theorem). *Any action of an irreducible solvable algebraic group  $G$  on a projective algebraic variety  $M$  possesses a fixed point.*

*Proof.* We will prove the theorem by induction in  $\dim G$ . Suppose  $\dim G > 0$  and assume that for groups whose dimension is less than  $\dim G$  the theorem holds. Let  $G'$  be the commutator subgroup of  $G$ . By the inductive hypothesis  $G'$  possesses fixed points on  $M$ . Let  $N$  be the set of all these points. It is easy to see that  $N$  is a closed subvariety. Since  $G'$  is normal in  $G$ , then  $N$  is  $G$ -invariant.

By the corollary of Theorem 1.7 there exists a closed orbit of the  $G$ -action on  $N$ . Let  $O$  be such an orbit. We have  $O = G/G_y$ , where  $G_y$  is the stabilizer of some point  $y \in O$ . Since  $G_y \supset G'$  and  $G/G'$  is commutative,  $G_y$  is a normal subgroup and  $G/G_y$  is an irreducible algebraic group and therefore an irreducible affine variety. But  $O$  is a projective variety. Therefore  $O$  consists of one point (see 2.2.5) which is the fixed point for the  $G$ -action on  $M$ .  $\square$

**Corollary 1** (Lie's theorem for algebraic groups). *Let  $R: G \rightarrow \text{GL}(V)$  be a linear representation of an irreducible solvable algebraic group  $G$ . There exists a one-dimensional subspace  $U \subset V$  invariant with respect to  $R(G)$ .*

This in its turn implies

**Corollary 2.** *Under the conditions of Corollary 1 there exists a basis of  $V$  in which all the operators  $R(g)$ ,  $g \in G$ , are expressed by (upper) triangular matrices.*

**7°. The Splitting of a Solvable Algebraic Group.** Let  $G$  be an irreducible solvable algebraic group.

**Problem 19.** The unipotent elements of  $G$  form an algebraic normal subgroup  $U$  in  $G$  containing  $G'$ .

This subgroup is called the *unipotent radical* of  $G$ .

**Problem 20.**  $G/U$  is a torus.

Actually a more precise statement holds.

**Theorem 10.** *Any irreducible solvable algebraic group splits into the semidirect product of its unipotent radical and a torus.*

*Proof.* Under the above notation consider an element of the torus  $G/U$  which is not contained in any of its proper algebraic subgroups (see Problem 12). The pre-image of this element with respect to the canonical homomorphism  $p: G \rightarrow G/U$  contains a semisimple element (Problem 16), say  $g$ . Denote by  $T$  the minimal algebraic subgroup of  $G$  containing  $g$ . It is a quasitorus (Problem 13). Therefore  $T \cap U = \{e\}$ . On the other hand, from the choice of  $g$  it is clear that  $p(T) = G/U$ . Therefore

$$G = U \rtimes T. \quad (3)$$

and  $T \simeq G/U$  is a torus.  $\square$

*Example.* For  $G = B_n(K)$  the unipotent radical  $U$  is the subgroup of unipotent matrices and for  $T$  we may take the group of invertible diagonal matrices.

*Remarks* about decomposition (3). Clearly, any algebraic subgroup of  $G$  containing  $T$  is the semidirect product of a unipotent subgroup contained in  $U$ , and  $T$ . In particular, this implies that  $T$  is a maximal torus in  $G$ , and any algebraic subgroup containing it is irreducible.

**Problem 21.** The normalizer of  $T$  in  $G$  coincides with the centralizer of  $T$ .

**8°. Semisimple Elements of a Solvable Algebraic Group**

**Theorem 11.** Let  $G$  be an irreducible solvable algebraic group and  $T$  a torus complementary to its unipotent radical  $U$ . Then any semisimple element of  $G$  is conjugate to some element of  $T$ .

**Problem 22.** Under the conditions of the theorem if  $U \neq \{e\}$  then there exists a unipotent algebraic normal subgroup  $U_1$  of  $G$  of codimension 1 in  $U$ .

*Proof of Theorem 11* will be carried out by induction in  $\dim U$ . If  $\dim U = 0$  then  $G = T$  and we have nothing to prove. Let  $\dim U = 1$  and  $g = ut$  ( $u \in U, t \in T$ ) a semisimple element. Consider two cases: when  $u$  and  $t$  commute and when they do not. In the first case the decomposition  $g = tu$  is the Jordan decomposition of  $g$ ; hence  $u = e$  and  $g \in T$ . In the other case the conjugacy class of  $g$  coincides with  $Ug$ . Indeed, since  $G/U$  is commutative, the conjugacy class  $C(h)$  of any  $h \in U$  is contained in  $Ug$ . It is an irreducible subvariety as an orbit of  $G$  and does not consist of one element  $h$  since  $uhu^{-1} \neq h$ . Therefore,  $C(h)$  is  $Ug$  without, perhaps, a finite number of points; but since this takes place for any  $h \in Ug$ , then  $C(h) = C(g) = Ug$ . In particular,  $C(g) \ni t$ , as required.

Now, let  $\dim U > 1$  and let the theorem hold for the groups whose unipotent radicals are of dimensions less than  $\dim U$ . Let  $U_1$  be an algebraic normal subgroup of  $G$  satisfying conditions of Problem 22 and  $p: G \rightarrow G/U_1$  the canonical homomorphism. Clearly,  $G/U_1$  is an irreducible solvable algebraic group with the one-dimensional unipotent radical  $p(U) = U/U_1$  and the complementary torus  $p(T) \simeq T$ . For any semisimple  $g \in G$  the element  $p(g)$  is, by the above, conjugate in  $G/U_1$  to an element of  $p(T)$ . This means that in  $G$  itself that element  $g$  is conjugate to a (semisimple) element  $g_1$  of  $G_1 = U_1 T$ . However, by the inductive hypothesis  $g_1$  is conjugate in  $G_1$  to some  $t \in T$ . Therefore  $g$  is conjugate in  $G$  to  $t$ .  $\square$

**Problem 23 (Corollary).** All maximal tori in a solvable algebraic group are conjugate to each other.

Now we may state that *any maximal torus* can be taken for  $T$  in (3).

**9°. Borel Subgroups.** While studying arbitrary (not necessarily solvable) algebraic groups it is convenient to consider their maximal irreducible solvable algebraic subgroups. Such subgroups are called *Borel subgroups*.

For  $GL_n(k)$  subgrc

The other. is a pr

Pro space a clos theore stabili since are ex irredu conju

Let group the p theref

Act cally of  $O$  comp

Pro conju

1) I c t

2) I

I

3) I

I

4) I

I

For instance, by Lie's theorem any irreducible solvable algebraic subgroup of  $GL_n(K)$  is conjugate to a subgroup contained in  $B_n(K)$ . Therefore  $B_n(K)$  is a Borel subgroup of  $GL_n(K)$  and any other Borel subgroup is conjugate to this one.

**Theorem 12.** *All Borel subgroups of an algebraic group  $G$  are conjugate to each other. The quotient space of a complex algebraic group modulo a Borel subgroup is a projective algebraic variety.*

*Proof.* We may assume that  $G$  is an algebraic linear group acting in a vector space  $V$ . The group  $G$  naturally acts on the flag variety  $F(V)$ , see 2.2.7. Let  $O$  be a closed orbit of this action. Since  $O$  is a projective variety, then by Borel's theorem any Borel subgroup of  $G$  has a fixed point in  $O$ , i.e. is contained in the stabilizer of a flag  $F \in O$ . On the other hand, the stabilizer of any flag is solvable since in a basis of  $V$  compatible with this flag all the elements of this group are expressed by triangular matrices. Therefore the Borel subgroups of  $G$  are irreducible components of the stabilizers of the points of  $O$  and therefore are conjugate to each other.

Let us prove the second statement of the theorem. Let  $G$  be a complex algebraic group and  $B$  its Borel subgroup. The quotient space  $G/B$  is a finite covering of the projective algebraic variety  $O$ , encountered in the above arguments, and therefore is compact and is also a projective algebraic variety.  $\square$

Actually, the second statement of the theorem holds over an arbitrary algebraically closed field [8]. Moreover, if  $G$  is irreducible then the stabilizers of points of  $O$  encountered in the proof are exactly the Borel subgroups of  $G$ . For the complex algebraic groups this latter assertion will be proved in §4.2.

**Problem 24 (Corollary).** All the maximal tori of an algebraic group  $G$  are conjugate to each other.

### Exercises

- 1) Let  $A = E + X$  be a unipotent operator. The linear operator  $A^t$  can be defined, apart from the method proposed in subsection 2°, directly with the help of the binomial series:

$$A^t = \sum_{k \geq 0} \frac{t(t-1)\dots(t-k+1)}{k!} X^k$$

- 2) Let  $g$  be an element of an algebraic group  $G$ . If  $g^m$  is semisimple for some positive integer  $m$  then  $g$  is semisimple.
- 3) If an irreducible component of the unit of an algebraic group  $G$  is a torus then all elements of  $G$  are semisimple.
- 4) For each element  $x$  of a torus  $T$  denote by  $\delta_x$  the character of  $X(T)$  defined by the formula  $\delta_x(\chi) = \chi(x)$ . The map

$$\delta: T \rightarrow \mathcal{X}(X(T)), \quad x \mapsto \delta_x,$$

is a group isomorphism.

- 5) There is a one-to-one correspondence between the tori homomorphisms  $T_1 \rightarrow T_2$  and the group homomorphisms  $\mathcal{X}(T_1) \rightarrow \mathcal{X}(T_2)$  which to any homomorphism  $f: T_1 \rightarrow T_2$  assigns the homomorphism  $f^*: \mathcal{X}(T_2) \rightarrow \mathcal{X}(T_1)$  defined by the formula

$$(f^*\chi)(x) = \chi(f(x)) \quad (\chi \in \mathcal{X}(T_2), x \in T_1).$$

- 6) Generalize Exercises 4 and 5 and the first statement of Theorem 5 to quasitori.
- 7) The intersection of the kernels of all characters of an algebraic group is a normal algebraic subgroup and the corresponding quotient group is a quasitorus.
- 8) Let a nondegenerate linear operator  $A \in GL(V)$  be expressed in a basis of  $V$  by a diagonal matrix  $\text{diag}(a_1, \dots, a_n)$ . Then  $G(A)$  consists of all invertible linear operators  $B$  which in the same basis are expressed by the matrices of the form  $\text{diag}(b_1, \dots, b_n)$ , where  $b_1, \dots, b_n$  satisfy all the relations of the form  $x_1^{k_1} \dots x_n^{k_n} = 1$  ( $k_1, \dots, k_n \in \mathbb{Z}$ ) which are satisfied by  $a_1, \dots, a_n$ .
- 9) Any nontrivial irreducible solvable algebraic group splits into the semidirect product of an algebraic normal subgroup of codimension 1 and an algebraic subgroup isomorphic to  $K^*$  or  $K$ .
- 10) Any nontrivial irreducible algebraic group has a nontrivial Borel subgroup. (Hint: analyze the proof of Theorem 12.)
- 11) Any nontrivial irreducible algebraic group contains an algebraic subgroup isomorphic to  $K^*$  or  $K$ . In particular, any one-dimensional irreducible algebraic group is isomorphic to  $K^*$  or  $K$ .
- 12) The closure of any solvable subgroup of an algebraic group is a solvable subgroup.
- 13) Any subgroup of an irreducible solvable algebraic group consisting of semisimple elements (in particular, any finite subgroup) is commutative.
- 14) Give an example of a solvable finite linear group which cannot be expressed in any basis by triangular matrices.
- 15) Any commutative linear group is expressed in some basis by triangular matrices.
- 16) Give an example of a commutative finite subgroup in  $\text{PGL}_2(K)$ , the quotient of  $\text{GL}_2(K)$  modulo its center, which is not contained in any Borel subgroup.
- 17) A commutative algebraic subgroup of an algebraic group is contained in some Borel subgroup if and only if so is the subgroup of its semisimple elements.

### Hints of Problems

1. To prove the first statement make use of condition 3) in the definition of a semisimple operator; to prove the second one make use of condition 2).
2. By induction: consider the restrictions of operators of the given family onto eigensubspaces of any nonscalar of these operators.
3. Let  $A = B + C$ , where  $B$  is semisimple,  $C$  nilpotent and  $BC = CB$ . For any

$\lambda \in K$  the subspace  $V_\lambda(B)$  is invariant with respect to  $C$  and, since  $C$  is nilpotent, we have

$$V_\lambda(B) \subset V^\lambda(A).$$

Since  $V = \bigoplus_\lambda V_\lambda(B)$ , then  $V_\lambda(B) = V^\lambda(A)$  for any  $\lambda \in K$ , hence  $B = A_s$ . The multiplicative decomposition is treated similarly.

4. Consider the formal series  $e(x) = \exp x - 1$  and  $l(x) = \log(1 + x)$ . Since the constant terms of these series vanish, we may well substitute one of them into another one. To solve the problem it suffices to show that

$$l(e(x)) = x, \quad e(l(x)) = x \quad (4)$$

For this make use of the fact that  $e(x)$  and  $l(x)$  have rational coefficients and define functions of a complex variable for which (4) holds in the functional sense for sufficiently small  $|x|$ .

5. Similarly to the proof of Problem 4 make use of formal series in two indeterminates.
6. The map  $t \mapsto A^t$  is a homomorphism of  $K$  onto an algebraic linear group  $H$  containing  $A$ . If  $A \neq E$  then the kernel of this homomorphism is a finite subgroup of  $K$  and therefore is the trivial group (recall that  $\text{char } K = 0$ ). Thus,  $H \cong K$  and similar arguments show that  $G(A) = H$ .
8. It suffices to prove that any character  $\chi$  of  $K^*$  is of the form  $\chi(x) = x^k$ , where  $k \in \mathbb{Z}$ . The simplest way to do this is to make use of the fact that a character  $\chi$  of  $K^*$  is a polynomial in  $x$  and  $x^{-1}$  such that  $\chi(x)\chi(x^{-1}) = 1$  and  $\chi(1) = 1$ .
12. These are the elements on which no nontrivial character takes the value 1. For instance, any element whose coordinates are different primes possesses this property.
13. Consider a basis in which  $A$  is expressed by a diagonal matrix and make use of Corollary of Theorem 5.
14. Make use of Problem 7.
15. It suffices to prove that  $G(A) \supset G(A_u)$ . Assume the contrary. Then  $G(A) \cap G(A_u) = \{E\}$ , i.e.  $G(A)$  has an isomorphic projection onto  $G(A_s)$ . Therefore  $G(A)$  is a quasitorus. But then by Problem 14 it has the trivial projection onto  $G(A_u)$  which is impossible.
16. Take any pre-image and consider its Jordan decomposition.
17. Follows from Problem 2 and Corollary of Theorem 5.
18. Let  $G$  be a commutative abstract group. The Jordan decomposition implies that  $G$  splits, as an abstract group, into the direct product of the subgroups  $G_s$  consisting of semisimple elements, and  $G_u$  consisting of unipotent elements. Let us prove that these subgroups are algebraic which implies the statement of the theorem with the help of Problem 17 and Theorem 2.

Assume that  $G$  is an algebraic linear group acting in a vector space  $V$ . Then  $G_u = G \cap L_u(V)$  is an algebraic subgroup. Next, take a basis in which all the operators of  $G_s$  are expressed by diagonal matrices. Equating to zero the nondiagonal elements of the matrix of  $A \in G$  in this basis we get a system of algebraic equations distinguishing  $G_s$ .

19. Apply Corollary 2 of Theorem 9 to a faithful linear representation of  $G$ . In a basis in which the operators of the representation are expressed by triangular matrices the unipotent elements of  $G$  are distinguished by the fact that all diagonal elements of the corresponding matrices are equal to 1.
20. By Problem 17 it suffices to prove that  $G/U$  is commutative, consists of semisimple elements and is irreducible. The first follows from Problem 19, the second is proved with the help of Problem 16, the third is obvious.
22. Passing to  $G/U'$  we may reduce the proof to the case of a commutative  $U$ . In this case by Theorem 2  $U$  is a vector group and the action of the torus  $T$  on it is linear. By Theorem 3  $U$  splits into the direct product of one-dimensional subgroups normalized by  $T$ . For  $U_1$  we may take the product of all these subgroups except any one of them.
23. Make use of Problem 12.
24. Follows from Theorem 12 and Corollary of Theorem 11.

### § 3. The Tangent Algebra

The tangent Lie algebra can be defined for an algebraic group over an arbitrary field (see e.g. [10]) but for simplicity we confine ourselves to  $\mathbb{C}$  and  $\mathbb{R}$ . In these cases no special definition is needed since any complex or real algebraic group is at the same time a Lie group and its tangent algebra may be understood in the sense of the Lie group theory.

**1°. Connectedness of Irreducible Complex Algebraic Groups.** The notion of the tangent algebra can be used to prove the following theorem.

**Theorem 1.** *Any irreducible complex algebraic group is connected.*

**Problem 1.** Any irreducible commutative complex algebraic group is connected.

*Proof of the theorem.* Let  $G$  be an irreducible complex algebraic group,  $\mathfrak{g}$  its tangent algebra. Consider some one-parameter subgroups  $P_1, \dots, P_n$  of  $G$  whose generators generate  $\mathfrak{g}$ . Denote by  $G_i (i = 1, \dots, n)$  the closure of  $P_i$  in the Zariski topology. This is a commutative algebraic subgroup. Since its irreducible components are closed in the real topology,  $P_i$  is entirely contained in one irreducible component; but this means that  $G_i$  is irreducible.

The subgroup  $\hat{G} \subset G$  generated by  $G_1, \dots, G_n$  is closed in the Zariski topology (Theorem 1.4). Its tangent algebra contains the tangent algebras of  $G_1, \dots, G_n$  and, in particular, the generators of  $P_1, \dots, P_n$ ; therefore it coincides with  $\mathfrak{g}$ . Thus  $\dim \hat{G} = \dim G$  and therefore  $\hat{G} = G$ .

By Problem 1 the subgroups  $G_1, \dots, G_n$  are connected and therefore, contained in the unit component of  $G$ . But by what we have already proved they generate  $G$ . Therefore  $G$  is connected.  $\square$

Thus, for a complex algebraic group its irreducibility is equivalent to its connectedness in the real topology. Notice that since irreducible components of an algebraic group do not intersect, its irreducibility is equivalent to its connectedness in the Zariski topology. All this being taken into account, we

will, speaking about complex algebraic groups, say “connected” instead of “irreducible” in order to avoid confusion with the irreducibility of linear groups which means the absence of nontrivial invariant subspaces.

**2°. The Rational Structure on the Tangent Algebra of a Torus.** Since a complex algebraic torus is a commutative Lie group, the Lie algebra structure on its tangent space is trivial. However, this space is naturally endowed with the structure of another kind.

Let  $T$  be an  $n$ -dimensional torus and  $\mathfrak{t}$  its tangent algebra. The differential  $d\chi$  (at the unit) of any character  $\chi \in \mathcal{X}(T)$  is a linear function on  $\mathfrak{t}$ . Clearly,

$$d(\chi_1 + \chi_2) = d\chi_1 + d\chi_2. \quad (1)$$

(Recall that  $\chi_1 + \chi_2$  is by definition the product of functions  $\chi_1$  and  $\chi_2$  on  $T$ . The sum on the right-hand side of identity (1) is the usual sum of linear functions on  $\mathfrak{t}$ .)

**Problem 2.** If  $(\varepsilon_1, \dots, \varepsilon_n)$  is a basis of  $\mathcal{X}(T)$  then  $(d\varepsilon_1, \dots, d\varepsilon_n)$  is a basis of the space  $\mathfrak{t}^*$  of linear functions on  $\mathfrak{t}$ .

For any additive number group  $A$ , set

$$\begin{aligned} f(A) &= \{ \xi \in \mathfrak{t} \mid d\chi(\xi) \in A \text{ for all } \chi \in \mathcal{X}(T) \} \\ &= \{ \xi \in \mathfrak{t} \mid d\varepsilon_i(\xi) \in A \text{ for } i = 1, \dots, n \}. \end{aligned}$$

If  $k$  is a number field, then  $f(k)$  is a  $k$ -form of the space  $\mathfrak{t}$  (see the definition in 2.3.6).

In the sequel, while speaking about the field over which the linear maps and subspaces of the tangent algebras of tori are defined we will have these very forms in mind.

**Problem 3.** The differential of any homomorphism (in particular, any automorphism) of a torus is defined over  $\mathbb{Q}$  (and the more so over any other number field).

**Problem 4.** The tangent algebras of algebraic subgroups of a torus are exactly the subspaces of its tangent algebra which are defined over  $\mathbb{Q}$ .

**3°. Algebraic Subalgebras.** Let  $G$  be a complex algebraic group. A subalgebra  $\mathfrak{h} \subset \mathfrak{g}$  is called *algebraic* if it is the tangent algebra of an algebraic subgroup  $H \subset G$  or, in other words, if the corresponding connected virtual Lie subgroup of  $G$  is an algebraic subgroup. As shown e.g. in Problem 4, certainly not any subalgebra is algebraic.

In this subsection we will find certain sufficient conditions for algebraicity of a subalgebra (and therefore sufficient conditions for this subalgebra to be the tangent algebra of a Lie subgroup). The existence of such conditions is one of the reasons why algebraic group theory is useful in the Lie group theory.

**Problem 5.** The derived algebra of an algebraic subalgebra is an algebraic subalgebra.

**Theorem 2.** *Let an algebraic subgroup  $H$  of a complex algebraic group  $G$  be generated by connected algebraic subgroups  $H_\alpha$ ,  $\alpha \in A$  for a set  $A$ . Then the tangent algebra  $\mathfrak{h}$  of  $H$  is generated by the tangent algebras  $\mathfrak{h}_\alpha$  of  $H_\alpha$ 's.*

**Problem 6.** Prove this theorem.

**Corollary.** *The subalgebra generated by any family of algebraic subalgebras is algebraic.*

Obviously the intersection of any family of algebraic subgroups is an algebraic subgroup. Therefore for any subalgebra  $\mathfrak{h} \subset \mathfrak{g}$  there exists the smallest algebraic subalgebra containing  $\mathfrak{h}$ . It is called the *algebraic closure* of  $\mathfrak{h}$  and is denoted by  $\mathfrak{h}^a$ .

**Problem 7.**  $\mathfrak{h}^a$  is the tangent algebra of the closure (in the Zariski topology) of the connected virtual Lie subgroup  $H \subset G$  corresponding to  $\mathfrak{h}$ .

The properties of the algebraic closure are similar to those of the Malcev closure (see 1.4.2).

**Theorem 3.** *Let  $\mathfrak{h}$  be a subalgebra of the tangent algebra of a complex algebraic group  $G$  and  $\mathfrak{h}^a$  its algebraic closure. Then  $(\mathfrak{h}^a)' = \mathfrak{h}'$ .*

This theorem is proved in exactly the same way as Theorem 1.4.3 (the subgroups  $H_1$  and  $H_2$  turn out to be algebraic: see Example 1.1.3)

**Corollary 1.** *The derived algebra of any subalgebra is an algebraic subalgebra. In particular, any subalgebra coinciding with its derived algebra is algebraic.*

**Corollary 2.** *The algebraic closure of a commutative (solvable) algebra is commutative (solvable).*

Maximal solvable subalgebras of  $\mathfrak{g}$  are called its *Borel subalgebras*.

**Problem 8.** Any Borel subalgebra of  $\mathfrak{g}$  is the tangent algebra of a Borel subgroup of  $G$ .

**Problem 9.** The algebraic closure of an ideal is an ideal.

**Problem 10.** The radical of  $G$  is an algebraic subgroup.

A linear Lie algebra  $\mathfrak{h} \subset \mathfrak{gl}(V)$  is called *algebraic* if it is algebraic as a subalgebra of the tangent algebra of  $GL(V)$ , i.e. if it is the tangent algebra of an algebraic linear group  $H \subset GL(V)$ .

All that has been stated in this subsection surely holds for  $G = GL(V)$ . In particular, Corollary 1 of Theorem 3 enables us to conclude that any linear Lie algebra coinciding with its derived algebra is algebraic.

#### 4°. The Algebraic Structure on Certain Complex Lie Groups

**Theorem 4.** *Let  $G$  be a connected complex algebraic group coinciding with its commutator group. Then any differentiable homomorphism of  $G$  into a complex algebraic group  $H$  is polynomial.*

*Proof.* Let  $f: G \rightarrow H$  be a differentiable homomorphism. Consider its graph  $\Gamma = \{(g, f(g)) \in G \times H: g \in G\}$ . Clearly  $\Gamma$  is a connected Lie subgroup of  $G \times H$  and its projection onto  $G$  is isomorphic to  $\Gamma$ . Its tangent algebra is isomorphic to the tangent algebra of  $G$ , hence it coincides with its derived algebra. Therefore  $\Gamma$  is an algebraic subgroup of  $G \times H$  (Corollary 1 of Theorem 3). By Theorem 1.6 the map  $g \mapsto (g, f(g))$ , inverse to the projection  $\Gamma \rightarrow G$  is polynomial. Therefore  $f$  is also polynomial.  $\square$

An algebraic structure on a complex Lie group  $G$  is an algebraic group structure on  $G$  compatible with the Lie group structure, i.e. generating the same Lie group structure. Since any algebraic group has a faithful linear representation, for the existence of an algebraic structure on a complex Lie group it is necessary that this group has a faithful linear representation (as a Lie group).

**Theorem 5.** *A connected complex Lie group coinciding with its commutator group and having a faithful linear representation admits a unique algebraic structure.*

**Problem 11.** Prove this theorem.

**5°. Engel's Theorem.** In this subsection we consider vector spaces and Lie algebras over an arbitrary field.

A linear Lie algebra  $\mathfrak{g} \subset \mathfrak{gl}(V)$  is called *unipotent* if all its operators are nilpotent. (The origin of this term will become clear in the sequel: see Problem 15.)

**Problem 12.** If a linear Lie algebra  $\mathfrak{g} \subset \mathfrak{gl}(V)$  is unipotent then so is the linear Lie algebra  $\text{ad } \mathfrak{g} \subset \mathfrak{gl}(\mathfrak{g})$ .

**Theorem 6 (Engel's theorem.)** *Let  $\mathfrak{g} \subset \mathfrak{gl}(V)$  be a unipotent linear Lie algebra. There exists a nonzero vector in  $V$  annihilated by all operators of  $\mathfrak{g}$ .*

*Proof* will be carried out by induction in  $\dim \mathfrak{g}$ . Suppose  $\dim \mathfrak{g} > 0$  and the statement holds for all linear Lie algebras whose dimensions are less than  $\dim \mathfrak{g}$ . Let  $\mathfrak{h}$  be a maximal subalgebra of  $\mathfrak{g}$ . Let us prove that  $\mathfrak{h}$  is an ideal of codimension 1.

Consider the linear representation  $\rho$  of  $\mathfrak{h}$  in  $\mathfrak{g}/\mathfrak{h}$  induced by the adjoint representation of  $\mathfrak{g}$ . Problem 12 implies that the linear Lie algebra  $\rho(\mathfrak{h})$  is unipotent. By the inductive hypothesis there exists a nonzero vector in  $\mathfrak{g}/\mathfrak{h}$  annihilated by all operators of  $\rho(\mathfrak{h})$ , i.e. there exists an element  $C \in \mathfrak{g} \setminus \mathfrak{h}$  such that  $[\mathfrak{h}, C] \subset \mathfrak{h}$ . But then  $\mathfrak{h} + \langle C \rangle$  is a subalgebra of  $\mathfrak{g}$  and the maximality of  $\mathfrak{h}$  implies that  $\mathfrak{h} + \langle C \rangle = \mathfrak{g}$ . With the above this means that  $\mathfrak{h}$  is ideal of codimension one.

Consider the subspace  $V_0 = \{v \in V: \mathfrak{h}v = 0\} \subset V$ . By the inductive hypothesis  $V_0 \neq 0$ . The fact that  $\mathfrak{h}$  is an ideal in  $\mathfrak{g}$  easily implies that  $V_0$  is  $\mathfrak{g}$ -invariant. Let  $C$  be any element of  $\mathfrak{g}$  which does not belong to  $\mathfrak{h}$ . Since  $C$  is nilpotent and  $V_0$  is invariant with respect to  $C$ , there exists a nonzero vector in  $V_0$  annihilated by  $C$ . Clearly, this vector is annihilated by all the operators of  $\mathfrak{g}$ .  $\square$

**Corollary 1.** *Under the conditions of the theorem there exists a basis of  $V$  with respect to which all operators of  $\mathfrak{g}$  are expressed by niltriangular matrices.*

This corollary is deduced from the theorem like the similar corollary of Lie's theorem, cf. 1.4.6. This in turn implies

**Corollary 2.** *Any unipotent Lie algebra is solvable.*

Engel's theorem implies not only the solvability but also the nilpotency of any unipotent linear Lie algebra. (For the definition of a nilpotent Lie algebra see Exercise 1.2.16.) In fact, the Lie algebra of niltriangular matrices is clearly nilpotent. Corollary 1 of Engel's theorem shows that any unipotent linear Lie algebra is isomorphic to some of its subalgebras and therefore is also nilpotent. However, the converse is false: there exist nilpotent Lie algebras which are not unipotent, e.g. Lie algebra of triangular matrices with equal elements on the diagonal.

**6°. Unipotent Algebraic Linear Groups.** Let  $V$  be a complex vector space.

**Problem 13.** An operator  $X \in \mathfrak{gl}(V)$  is nilpotent (semisimple) if and only if  $\exp tX$  is unipotent (semisimple) for any  $t \in \mathbb{C}$ .

For any nilpotent  $X \in \mathfrak{gl}(V)$  the linear group  $\{\exp tX : t \in \mathbb{C}\}$  is algebraic, see 2.2. Clearly, its tangent algebra is generated by  $X$ . Therefore any one-dimensional unipotent linear Lie algebra is algebraic.

**Problem 14.** Any unipotent linear Lie algebra is algebraic.

**Problem 15.** A connected algebraic linear group is unipotent (see 2.2) if and only if its tangent algebra is unipotent.

This explains the term "unipotent" applied to the linear Lie algebras.

**Theorem 7.** *Any unipotent complex algebraic linear group  $G \subset \mathrm{GL}(V)$  is solvable and is expressed in some basis by unitriangular matrices. The map  $\exp: \mathfrak{g} \rightarrow G$  is an isomorphism of algebraic varieties.*

**Problem 16.** Prove this theorem.

Notice that the last statement of the theorem makes sense independently of a linear representation of  $G$ .

**7°. The Jordan Decomposition in the Tangent Algebra of an Algebraic Group.**

Let  $G$  be a complex algebraic group. For any  $\xi \in \mathfrak{g}$  denote by  $G(\xi)$  the smallest algebraic subgroup of  $G$  whose tangent algebra contains  $\xi$ , i.e. the closure (in the Zariski topology) of the subgroup  $\{\exp t\xi : t \in \mathbb{C}\}$ . This is an irreducible commutative algebraic group. By Corollary of Theorem 2.8 it splits into the direct product of a torus and a vector group.

An element  $\xi \in \mathfrak{g}$  is called *semisimple (nilpotent)* if  $G(\xi)$  is a torus (a vector group).

**Problem 17.** Let  $f: G \rightarrow H$  be an algebraic group homomorphism. If  $\xi \in \mathfrak{g}$  is semisimple (nilpotent) then so is  $df(\xi) \in \mathfrak{h}$ .

**Problem 18.** Let  $R$  be a linear representation of  $G$ . If  $\xi \in \mathfrak{g}$  is semisimple (nilpotent) then so is the linear operator  $dR(\xi)$ .

**Theorem 8.** Any element  $\xi$  of the tangent algebra  $\mathfrak{g}$  of a complex algebraic group  $G$  can be uniquely presented in the form of the sum of commuting semisimple and nilpotent elements  $\xi_s, \xi_n$ .

The elements  $\xi_s$  and  $\xi_n$  are called the *semisimple* and *nilpotent* parts of  $\xi$  respectively and the decomposition  $\xi = \xi_s + \xi_n$  is called its *Jordan decomposition*.

**Problem 19.** Prove Theorem 8.

**Problem 20.** Let  $R$  be a locally faithful (i.e. with a finite kernel) linear representation of  $G$  and  $\xi \in \mathfrak{g}$ . If  $dR(\xi)$  is semisimple (nilpotent) then so is  $\xi$ .

Problems 18 and 20 show in particular that semisimple and nilpotent elements of the tangent algebra of  $GL(V)$  are same as semisimple and nilpotent linear operators.

**Problem 21.** Let  $f: G \rightarrow H$  be an algebraic group homomorphism. For any semisimple (nilpotent) element  $\eta \in df(\mathfrak{g})$  its pre-image  $(df)^{-1}(\eta)$  contains a semisimple (nilpotent) element.

**8°. The Tangent Algebra of a Real Algebraic Group.** Let  $G$  be a real algebraic group,  $\mathfrak{g}$  its tangent algebra (as of a real Lie group),  $G(\mathbb{C})$  its complexification, see 1.1.

The tangent algebra of  $G(\mathbb{C})$  coincides with the complexification  $\mathfrak{g}(\mathbb{C})$  of  $\mathfrak{g}$ , see 2.3.4. If  $\tau$  is the complex conjugation on  $G(\mathbb{C})$  then  $d\tau$  is the complex conjugation on  $\mathfrak{g}(\mathbb{C})$ .

**Problem 22.** A connected algebraic subgroup of  $G(\mathbb{C})$  is a complexification of an algebraic subgroup of  $G$  if and only if its tangent algebra is defined over  $\mathbb{R}$  (as a subspace of  $\mathfrak{g}(\mathbb{C})$ ).

A Lie subalgebra  $\mathfrak{h} \subset \mathfrak{g}$  is called *algebraic* if it is the tangent algebra of an algebraic subgroup  $H \subset G$ . For any subalgebra  $\mathfrak{h} \subset \mathfrak{g}$  there exists the smallest algebraic subalgebra containing  $\mathfrak{h}$ . It is called the *algebraic closure* of  $\mathfrak{h}$  and is denoted by  $\mathfrak{h}^a$ .

**Problem 23.** The subalgebra  $\mathfrak{h} \subset \mathfrak{g}$  is algebraic if and only if its complexification  $\mathfrak{h}(\mathbb{C})$  is an algebraic subalgebra of  $\mathfrak{g}(\mathbb{C})$ . In any case  $\mathfrak{h}^a(\mathbb{C}) = \mathfrak{h}(\mathbb{C})^a$ .

Due to this fact most of the results of 3° are routinely carried over to the real setting. In particular, in this way we obtain that the following subalgebras of  $\mathfrak{g}$  are algebraic:

- 1) the derived algebra of any subalgebra; in particular, any subalgebra coinciding with its derived algebra;
- 2) a subalgebra generated by any family of algebraic subalgebras;
- 3) the radical of  $\mathfrak{g}$ .

**9°. The Union of Borel Subgroups and the Centralizers of Tori.** Let  $G$  be a connected complex algebraic group,  $\mathfrak{g}$  its tangent algebra.

**Problem 24.** Any element of  $\mathfrak{g}$  is contained in some of Borel subalgebras.

**Problem 25.** The union of all Borel subgroups of  $G$  is an épais subset in  $G$ . Actually, the following statement holds:

**Theorem 9.** *Every element of a connected complex algebraic group is contained in some of its Borel subgroups.*

*Proof.* Let  $U$  be the union of all Borel subgroups of  $G$ . It follows from Problem 25 that  $U$  is dense in  $G$  in the real topology. Therefore it suffices to prove that  $U$  is closed in the real topology.

We have  $U = \bigcup_{g \in G} gBg^{-1}$ , where  $B$  is a fixed Borel subgroup of  $G$ . Let the sequence of elements  $g_n b_n g_n^{-1}$  ( $g_n \in G$ ,  $b_n \in B$ ) converge to some  $g \in G$ . Since  $G/B$  is compact (Theorem 2.12), then, passing to a subsequence, we may assume that  $g_n = g'_n c_n$ , where  $g'_n \rightarrow h \in G$  and  $c'_n \in B$ , but then

$$c_n b_n c_n^{-1} \rightarrow h^{-1} g h = b \in B$$

hence,  $g = h b h^{-1} \in U$ .  $\square$

The combination of this theorem with Theorem 2.11 and Corollary of Theorem 2.12 yields the following two corollaries.

**Corollary 1.** *Every semisimple element of  $G$  is contained in a torus.*

**Corollary 2.** *Every central semisimple element of  $G$  is contained in the intersection of all maximal tori of  $G$ .*

**Problem 26.** Let  $S \subset G$  be a torus and  $g \in G$  a semisimple element commuting with it. Then there exists a torus  $T \subset G$  containing  $S$  and  $g$ .

**Theorem 10.** *The centralizer  $Z(S)$  of any torus  $S$  in a connected complex algebraic group  $G$  is connected.*

**Problem 27.** Prove the theorem.

### Exercises

- 1) The subgroup  $\{(e^z, e^{iz}) : z \in \mathbb{C}\} \subset (\mathbb{C}^*)^2$  is a Lie subgroup but not an algebraic subgroup.
- 2) Any differentiable linear representation of a complex algebraic torus is polynomial.
- 3) Give an example of a nonpolynomial differentiable linear representation of  $\mathbb{C}$ .
- 4) The complex Lie group  $\mathbb{C}/(\mathbb{Z} + i\mathbb{Z})$  does not admit an algebraic structure. (For a broader interpretation of the notion of an algebraic group, which does not require that the group variety is affine, this Lie group admits an algebraic structure. However, there are examples of complex Lie groups which do not admit an algebraic structure in this broader sense either.)
- 5) The complex Lie group  $\mathbb{C} \times \mathbb{C}^*$  admits a continuum of different algebraic structures.
- 6) An algebraic normal subgroup of a connected complex algebraic group  $G$  which is a quasitorus is contained in the center of  $G$ .

- 7) An element  $\xi$  of the tangent algebra of a complex algebraic group  $G$  is semisimple if and only if  $\exp \xi \in G$  is semisimple.
- 8) A Lie algebra  $\mathfrak{g}$  (over an arbitrary field) is nilpotent if and only if the linear Lie algebra  $ad \mathfrak{g}$  is unipotent.
- 9) The derived algebra of any solvable subalgebra of the tangent algebra of a complex algebraic group is unipotent (i.e. all its elements are nilpotent).
- 10) Given a linear operator  $X \in \mathfrak{gl}(V)$  let  $\mathfrak{g}(X)$  be the smallest algebraic linear Lie algebra which contains it, i.e. the algebraic closure of the one-dimensional linear Lie algebra  $\langle X \rangle$ . If  $X = X_s + X_n$  is the additive Jordan decomposition of  $X$  then  $\mathfrak{g}(X) = \mathfrak{g}(X_s) \oplus \langle X_n \rangle$ .
- 11) Under the notation of Exercise 10 if  $X$  is expressed in some basis by a diagonal matrix  $\text{diag}(x_1, \dots, x_n)$  then  $\mathfrak{g}(X)$  consists of all operators which in the same basis are expressed by matrices of the form  $\text{diag}(y_1, \dots, y_n)$ , where  $y_1, \dots, y_n$  satisfy all linear equations with integer coefficients satisfied by  $x_1, \dots, x_n$ .
- 12) Under the notation of 7° the dimension of the vector factor of  $G(\xi)$  does not exceed 1.

### Hints to Problems

4. Make use of the description of algebraic subgroups of a torus given in Theorem 2.5.
5. Follows from Theorems 1.5 and 1.4.1.
6. Let  $\hat{\mathfrak{h}} \subset \mathfrak{h}$  be a subalgebra generated by  $\mathfrak{h}_\alpha, \alpha \in A$ , and  $\hat{H} \subset H$  the corresponding connected virtual Lie subgroup (cf. Theorem 1.2.8). For any  $\alpha \in A$  we have  $\hat{\mathfrak{h}} \supset \mathfrak{h}_\alpha$ , hence  $\hat{H} \supset H_\alpha$ . Therefore  $\hat{H} = H$  and  $\hat{\mathfrak{h}} = \mathfrak{h}$ .
8. First prove that any Borel subalgebra is an algebraic subalgebra.
9. Solution is similar to that of Problem 1.4.6.
10. Prove that the radical of  $\mathfrak{g}$  is an algebraic subalgebra.
12. It is subject to a straightforward verification that if  $X^m = 0$  then  $(ad X)^{2m-1} = 0$ .
13. First prove the "only if" part. After this prove that  $\exp tX = (\exp tX_s)(\exp tX_n)$  is the (multiplicative) Jordan decomposition of  $\exp tX$ .
14. Follows from the remark made just before the formulation of the problem and Corollary of Theorem.
15. The "if" part is proved with the help of Corollary 1 of Engel's theorem. The "only if" part follows from Problem 13.
16. The first part of the theorem follows from Problem 15 and corollaries of Engel's theorem. The surjectivity of  $\exp: \mathfrak{g} \rightarrow G$  follows from the fact that together with  $A$  the group  $G$  contains the subgroup  $G(A) = \{\exp tX: t \in \mathbb{C}\}$ , where  $X = \log(A)$ , cf. Theorem 2.1. The remaining properties of the map  $\exp$  are proved with the help of Problem 2.4.
17. Notice that the element  $df(\xi)$  is contained in the tangent algebra of the algebraic subgroup  $f(G(\xi)) \subset H$ .
18. Make use of the hint to Problem 17 and of Problem 13.
19. Let  $G(\xi) = T \times U$ , where  $T$  is a torus and  $U$  a vector group. If  $\mathfrak{g}(\xi) = \mathfrak{t} \oplus \mathfrak{u}$

is the corresponding decomposition of the tangent algebra then the decomposition  $\xi = \xi_s + \xi_n$ , where  $\xi_s \in \mathfrak{t}$  and  $\xi_n \in \mathfrak{u}$ , is the desired one. The uniqueness of the desired decomposition follows, due to Problem 18, from the uniqueness of the additive Jordan decomposition of a linear operator.

20. Consider the Jordan decomposition of  $\xi$  and make use of Problem 18.
21. Take any pre-image and consider its Jordan decomposition.
22. Problem 1.10 implies that a connected algebraic subgroup  $H \subset G(\mathbb{C})$  is a complexification of an algebraic subgroup of  $G$  if and only if  $\tau(H) = H$  and this, in turn, is equivalent to the fact that  $d\tau(\mathfrak{h}) = \mathfrak{h}$ . Next, make use of Problem 2.3.29.
23. Notice that if the subalgebra  $\mathfrak{h}(\mathbb{C})$  is algebraic then the corresponding connected algebraic subgroup of  $G(\mathbb{C})$  is according to the Problem 22 a complexification of an algebraic subgroup of  $G$ . The second statement follows from the first one.
26. By Corollary 1 of Theorem 9  $g$  is contained in a torus. Let  $H \subset G$  be the subgroup generated by this torus and  $S$ . This is a connected algebraic subgroup by Theorem 1.4 and  $g$  belongs to its center. Let  $T$  be a maximal torus of  $H$  containing  $S$ . By Corollary 2 of Theorem 9  $T \ni g$ .
27. It suffices to prove that any semisimple element of  $Z(S)$  is contained in  $Z(S)^0$  but this follows from Problem 26.

#### §4. Compact Linear Groups

Compact linear groups give an example when the algebraicity follows from a topological assumption. Namely, any compact linear group acting in a real vector space is algebraic (and therefore, it is a Lie group). This will constitute one of the theorems of this section.

**1°.** **A Fixed Point Theorem.** Proofs of all properties of compact linear groups contained in this section are based on the following theorem.

**Theorem 1.** *Let  $G$  be a compact subgroup of the group  $GA(S)$  of affine transformations of a real affine space  $S$  and let  $M \subset S$  be a nonempty convex  $G$ -invariant subset. Then  $M$  contains a fixed point of  $G$ .*

Before we proceed with the proof of this theorem define the *center of mass* of a nonempty bounded convex subset  $M$  of a real affine space  $S$  to be

$$c(M) = \mu(M)^{-1} \int_M x \mu(dx),$$

where  $\mu$  is the usual measure in  $S$  invariant with respect to parallel translations. The measure  $\mu$  is defined up to a constant factor but it is clear from the formula that the ambiguity in the choice of  $\mu$  does not affect the results. The integral on

the ri  
limit  
into a  
equal  
the in  
syste

In  
none  
but v

Pr

Sir  
for a  
to a  
trans

Pr  
point  
an in  
point

Ap

Co

2°.

Th  
(com,  
form

In  
trans

Pr  
linea  
form

Co  
comp

Re  
nont  
into  
of th  
grou

Pr  
for a  
subsj

the right-hand side can be defined either 1) coordinate-wise or 2) directly, as the limit of integral sums which are (the factor preceding the integral being taken into account) linear combinations of points of  $S$  with the sum of coefficients being equal to 1, and therefore make sense. The first definition shows the existence of the integral and the second one its independence of the choice of a coordinate system.

In general case let  $P$  be the smallest plane in  $S$  containing  $M$ . Then  $M$  has a nonempty interior as a subset of the affine space  $P$  and we define  $c(M)$  as above but with  $S$  replaced by  $P$ .

**Problem 1.**  $c(M) \in M$ .

Since the center of mass is defined in terms of affine geometry,  $c(gM) = gc(M)$  for any affine transformation  $g$  of  $S$ . In particular, if  $M$  is invariant with respect to an affine transformation then its center of mass is a fixed point of this transformation.

*Proof of the theorem.* If  $M$  is bounded then its center of mass will do as a fixed point. In general let  $M'$  be the convex hull of an orbit of  $G$  in  $M$ . Clearly,  $M'$  is an invariant subset. Since the orbit is compact, its convex hull is bounded. The point  $c(M') \in M' \subset M$  is the desired fixed point.

Applying the theorem to  $M = S$  we get

**Corollary.** *Any compact group of affine transformations has a fixed point.*

## 2°. Complete Reducibility

**Theorem 2.** *Let  $G$  be a compact group of linear transformations of a real (complex) vector space  $V$ . Then there exists a positive definite quadratic (Hermitian) form on  $V$  invariant with respect to  $G$ .*

In other words  $V$  can be made into a Euclidean (Hermitian) space so that all transformations of  $G$  are orthogonal (unitary).

*Proof* is obtained by applying Theorem 1 to the image of  $G$  under the natural linear representation of  $GL(V)$  in a (real) space  $S$  of all quadratic or Hermitian forms on  $V$ . For  $M$  take the subset of positive definite forms.  $\square$

**Corollary.** *Any compact linear group in a real or complex vector space is completely reducible.*

Recall that a linear group  $G \subset GL(V)$  is *irreducible* if  $V \neq 0$  and there are no nontrivial  $G$ -invariant subspaces in  $V$  and *completely reducible* if  $V$  decomposes into the direct sum of  $G$ -invariant subspaces so that the restriction of  $G$  onto any of them is irreducible. (Notice a linguistic inconsistency: any irreducible linear group is completely reducible!)

**Problem 2.** A linear group  $G \subset GL(V)$  is completely reducible if and only if for any  $G$ -invariant subspace of  $V$  there exists a  $G$ -invariant complementary subspace.

If  $V$  is a Euclidean (Hermitian) space and all transformations from  $G$  are orthogonal (unitary) then for a complementary invariant space we can take the orthogonal complement which implies the above Corollary.

**3°. Separating Orbits with the Help of Invariants.** Let  $V$  be a (finite-dimensional) vector space over an infinite field  $K$ . Every linear operator  $A \in GL(V)$  determines an automorphism  $A^*$  of the polynomial algebra  $K[V]$  acting via the formula

$$(A^*f)(x) = f(A^{-1}x) \quad (f \in K[V], x \in V)$$

The map  $A \mapsto A^*$  is a linear representation of  $GL(V)$  in  $K[V]$ . This representation is infinite-dimensional but is the inductive limit of finite-dimensional ones:  $K[V]$  is the union of the increasing chain of finite-dimensional  $GL(V)$ -invariant subspaces  $K[V]^{(m)}$ ,  $m = 0, 1, \dots$ , where  $K[V]^{(m)}$  consists of polynomials of degree  $\leq m$ .

Now, let  $G \subset GL(V)$  be a subgroup. A polynomial  $f \in K[V]$  is  $G$ -invariant if  $A^*f = f$  or, equivalently, if

$$f(Ax) = f(x) \quad \text{for any } A \in G, x \in V.$$

In other words, a polynomial  $f$  is  $G$ -invariant if it is constant on every orbit of  $G$ . The invariant polynomials constitute a subalgebra of  $K[V]$  denoted by  $K[V]^G$ .

We say that *two orbits of  $G$  are separated by invariants* if for any  $x, y \in V$  that belong to different orbits there exists  $f \in K[V]^G$  such that  $f(x) \neq f(y)$ .

For example, let  $G = S_n$ , where  $n = \dim V$ , be the symmetric group which acts in  $V$  permuting the vectors of a fixed basis. Then  $K[V]^G$  is the algebra of symmetric polynomials (in the coordinate system corresponding to the basis). As is known, this algebra is generated by the elementary symmetric polynomials  $\sigma_1, \dots, \sigma_n$ . Let us prove that the orbits of  $G$  are separated by the invariants. To each  $x \in V$  with coordinates  $x_1, \dots, x_n$  assign the polynomial

$$\varphi_x(t) = (t - x_1) \dots (t - x_n) = t^n - \sigma_1(x)t^{n-1} + \dots + (-1)^n \sigma_n(x)$$

in a variable  $t$  with roots  $x_1, \dots, x_n$ . If  $x$  and  $y$  belong to different orbits of  $G$ , i.e. the coordinates of one of them cannot be obtained from the coordinates of another by permutation then  $\varphi_x \neq \varphi_y$  and therefore  $\sigma_k(x) \neq \sigma_k(y)$  for some  $k$ .

It is possible to show that the orbits of any finite linear group are separated by the invariants. On the contrary, for infinite groups this is seldom so. For instance consider a classical situation. Let  $V = L_n(K)$  be the space of matrices over an algebraically closed field  $K$  and let  $G \subset GL(V)$  be the group of transformations  $X \mapsto AXA^{-1}$  ( $X \in L_n(K)$ ,  $A \in GL_n(K)$ ). Then the orbits of  $G$  are the classes of similar matrices and  $K[V]^G$ , as it is not difficult to show, is generated by the coefficients of the characteristic polynomial (which are polynomials in the matrix elements). Therefore the matrices with the same characteristic polynomials but different Jordan forms are not separated by the invariants although they belong to different orbits.

**Theorem 3.** *The orbits of a compact linear group acting in a real vector space are separated by the invariants.*

*Proof.* Let  $O_1$  and  $O_2$  be different orbits of a compact linear group  $G$  acting in a real vector space  $V$ . Since  $O_1$  and  $O_2$  are nonintersecting compact subsets, there exists a continuous function  $\varphi$  on  $V$  equal 1 on  $O_1$  and  $-1$  on  $O_2$ . Furthermore, by Weierstrass's theorem there exists  $f \in R[V]$  such that

$$|f(x) - \varphi(x)| < 1 \quad \text{for } x \in O_1 \cup O_2$$

and therefore

$$f(x) > 0 \quad \text{for } x \in O_1 \quad \text{and} \quad f(x) < 0 \quad \text{for } x \in O_2 \quad (1)$$

Let  $m$  be the degree of this polynomial.

In  $S = \mathbb{R}[V]^{(m)}$ , consider the subset  $M$  consisting of all polynomials satisfying (1). Clearly,  $M$  is convex and invariant with respect to the natural linear representation of  $G$  in  $S$ . By Theorem 1 there exists a  $G$ -invariant polynomial in  $M$ . It is clear from (1) that the values of this polynomial at the points of  $O_1$  are different from the values at the points of  $O_2$ .  $\square$

*Example.* Let  $V$  be the space of symmetric real matrices of order  $n$ . To each orthogonal  $n \times n$  matrix  $A$  assign a linear transformation  $R(A)$  of  $V$  by the formula

$$R(A)X = AXA^{-1} \quad (X \in V).$$

Then we get a linear representation  $R: O_n \rightarrow GL(V)$ . Let  $G = R(O_n)$ . This is a compact linear group acting on the space  $V$ . As it is known from the linear algebra, each orbit of this group contains a diagonal matrix. Therefore the orbit which contains the symmetric matrix  $X$  is determined by the characteristic polynomial of this matrix. Since the coefficients of a characteristic polynomial are  $G$ -invariant polynomials in the elements of  $X$ , the orbits of  $G$  are separated by the invariants as it should be according to the theorem.  $\square$

#### 4°. Algebraicity

**Theorem 4.** *The orbits of a compact linear group  $G$  acting on a real vector space  $V$  are algebraic varieties in  $V$ .*

*Proof.* Let  $O$  be an orbit and  $I$  an ideal of  $\mathbb{R}[V]^G$  consisting of invariants which vanish on  $O$ . By Theorem 3 for any orbit  $O' \neq O$  there exists an invariant which takes different values on  $O$  and  $O'$ . Adding to it an appropriate constant we can get a polynomial  $f \in I$  which does not vanish at any point of  $O'$ . Thus, the set of zeros of  $I$  coincides with  $O$  implying that  $O$  is an algebraic variety in  $V$ .  $\square$

**Theorem 5.** *Any compact linear group acting on a real vector space is algebraic (and therefore is a linear Lie group).*

*Proof.* Let  $G \subset GL(V)$  be a compact linear group. Consider a linear representation  $R$  of  $G$  in the space  $L(V)$  defined by the formula

$$R(A)X = AX \quad (A \in GL(V), X \in L(V)).$$

The group  $G$ , as a subset of  $L(V)$ , is an orbit of  $R(G)$  (namely  $G = R(G)E$ ). By Theorem 4 this implies that  $G$  is algebraic.  $\square$

Notice that a similar theorem fails over  $\mathbb{C}$ . More precisely, the following statement holds.

**Problem 3.** Any compact complex algebraic group is finite.

However, Theorem 5 implies that any compact linear group acting on a complex vector space  $V$  is an algebraic subgroup of the group of invertible linear transformations of  $V$  considered as a real vector space and therefore a real algebraic subgroup of  $GL(V)$ .

In Chapter 5 we will obtain a classification of connected compact linear groups and prove that any compact Lie group admits a faithful linear representation.

### Exercises

- 1) Let  $G$  be an irreducible compact linear group acting on a real (complex) vector space  $V$ . Then a  $G$ -invariant positive definite quadratic (Hermitian) form on  $V$  is unique up to a positive factor.
- 2) A linear operator in a vector space over an algebraically closed field is semisimple if and only if the cyclic linear group it generates is completely reducible.
- 3) The orbits of any finite linear group (over an arbitrary field) are separated by the invariants.
- 4) Let  $V = L_n(K)$  be the space of matrices over an algebraically closed field  $K$  and let  $G \subset GL(V)$  be the group consisting of transformations

$$X \mapsto AXA^{-1} \quad (X \in L_n(K), A \in GL_n(K)).$$

Then  $K[V]^G$  is generated by the coefficients of the characteristic polynomial. (Hint: consider the restrictions of invariants onto the subspace of diagonal matrices.)

- 5) In the notations of Exercise 4 the orbit of  $X \in L_n(K)$  is closed in  $L_n(K)$  if and only if  $X$  is similar to a diagonal matrix.

### Hints to Problems

1. We can assume that  $M$  has a nonempty interior. In this case suppose  $c(M) \notin M$ . Then there exists an affine function  $l$  on  $S$  positive at all interior points of  $M$  and vanishing at  $c(M)$ . But this is impossible since the definition of the center of mass implies that

$$l(c(M)) = \mu(M)^{-1} \int_M l(x) \mu(dx) > 0.$$

2. Let  $V = V_1 \oplus \cdots \oplus V_m$  be the decomposition of  $V$  into the direct sum of invariant subspaces on each of which  $G$  acts irreducibly and let  $U \subset V$  be an invariant subspace. Then as an invariant subspace complementary to  $U$  we can always take the sum of a certain number of subspaces  $V_1, \dots, V_m$ .
3. More generally, an irreducible complex affine variety of positive dimension cannot be compact: see 2.2.5.

## Chapter 4

### Complex Semisimple Lie Groups

This chapter deals with the most explored section of the theory of Lie groups and Lie algebras. Its main result is the complete classification of connected complex semisimple Lie groups and their irreducible linear representations. This classification is based on the theory of root systems, which because of its numerous applications deserves a special treatment. The theory is axiomatically developed in § 2. During the whole chapter (except 1.1°–1.3°) the ground field is  $\mathbb{C}$ . All the vector spaces and Lie algebras considered are finite-dimensional.

#### § 1. Preliminaries

**1°. Invariant Scalar Products.** Let  $G$  be a Lie group (real or complex). A bilinear function  $b$  on the tangent algebra  $\mathfrak{g}$  of  $G$  is said to be *invariant* if it is invariant with respect to  $\text{Ad } G$ , i.e. if

$$b((\text{Ad } g)x, (\text{Ad } g)y) = b(x, y)$$

for any  $g \in G$ ,  $x, y \in \mathfrak{g}$ .

**Problem 1.** An invariant bilinear function  $b$  on  $\mathfrak{g}$  satisfies

$$b([x, y], z) + b(y, [x, z]) = 0 \tag{1}$$

for any  $x, y, z \in \mathfrak{g}$ . If  $G$  is connected then the converse statement holds: any bilinear function  $b$  on  $\mathfrak{g}$  satisfying (1) is invariant.

Now let  $\mathfrak{g}$  be a Lie algebra over an arbitrary field  $K$ . A bilinear function  $b$  on  $\mathfrak{g}$  satisfying (1) is called *invariant*. If, in addition,  $b$  is symmetric we will call  $b$  an *invariant scalar product* on  $\mathfrak{g}$ .

*Examples.* 1) Let  $E$  be the three-dimensional Euclidean space with the scalar product  $(\cdot, \cdot)$ . Fixing an orientation on  $E$  we make  $E$  into a Lie algebra over  $\mathbb{R}$  with respect to the vector product, and the scalar product  $(\cdot, \cdot)$  is invariant.

2) In  $\mathfrak{gl}(V)$ , there is the canonical invariant scalar product

$$(X, Y) = \text{tr } XY. \tag{2}$$

3) Let  $\mathfrak{g}$  be an arbitrary Lie algebra,  $\rho: \mathfrak{g} \rightarrow \mathfrak{gl}(V)$  its linear representation. Then the bilinear function

$$(x, y)_\rho = (\rho(x), \rho(y)) = \text{tr}(\rho(x)\rho(y))$$

is an invariant scalar product on  $\mathfrak{g}$ . In particular, on any Lie algebra  $\mathfrak{g}$  the invariant scalar product

$$(x, y)_{\text{ad}} = \text{tr}((\text{ad } x)(\text{ad } y))$$

is defined; it is called the *Cartan scalar product* (or the *Killing bilinear function*). It is not difficult to verify that this scalar product is invariant with respect to all the automorphisms  $\alpha$  of  $\mathfrak{g}$ :

$$(\alpha(x), \alpha(y))_{\text{ad}} = (x, y)_{\text{ad}}.$$

Let  $(\cdot, \cdot)$  be an invariant scalar product on a Lie algebra  $\mathfrak{g}$ . For any subspace  $\mathfrak{a} \subset \mathfrak{g}$  the orthogonal complement is defined:

$$\mathfrak{a}^\perp = \{x \in \mathfrak{g}: (x, y) = 0 \text{ for all } y \in \mathfrak{a}\}.$$

**Problem 2.** If  $\mathfrak{a}$  is an ideal of  $\mathfrak{g}$ , then so is  $\mathfrak{a}^\perp$ .

Let  $V$  be a vector space over  $K$  and  $\mathfrak{g}$  a subalgebra of  $\mathfrak{gl}(V)$ . The embedding  $\mathfrak{g} \rightarrow \mathfrak{gl}(V)$  defines an invariant scalar product  $(\cdot, \cdot)$  on  $\mathfrak{g}$  (see Example 3); it is defined by (2). We wish to specify (for  $K = \mathbb{C}$ ) those algebraic linear Lie algebras for which this scalar product is nondegenerate.

A complex linear Lie algebra  $\mathfrak{t}$  is called *diagonalizable* if it is commutative and all its elements are semisimple.

**Problem 3.** A complex algebraic linear Lie algebra is diagonalizable if and only if it is the tangent algebra of a torus.

**Problem 4.** Let  $\mathfrak{t}$  be a diagonalizable complex algebraic linear Lie algebra. Then the scalar product (2) is nondegenerate on  $\mathfrak{t}$  and positive definite on the real form  $\mathfrak{t}(\mathbb{R})$  (see 3.3.2°).

**Problem 5.** Let  $\mathfrak{n}$  be a complex linear Lie algebra, on which the scalar product (2) vanishes identically. If  $\mathfrak{n}$  is algebraic then it is unipotent; in general case it is solvable.

**Problem 6.** If  $\mathfrak{n}$  is a unipotent ideal of a linear Lie algebra  $\mathfrak{g}$  then  $(\mathfrak{n}, \mathfrak{g}) = 0$ .

**Problem 7.** Let  $K = \mathbb{C}$  or  $\mathbb{R}$  and let  $\mathfrak{g}$  be a semisimple linear Lie algebra. Then the scalar product (2) is nondegenerate on  $\mathfrak{g}$ .

Notice that any semisimple Lie algebra admits a faithful linear representation, e.g. the adjoint one. Therefore it may always be assumed linear. Problem 7 implies

**Theorem 1.** Any semisimple Lie algebra  $\mathfrak{g}$  over  $\mathbb{C}$  or  $\mathbb{R}$  possesses a nondegenerate invariant scalar product. In particular, the Cartan scalar product on  $\mathfrak{g}$  is nondegenerate.

**Problem 8.** If there is an invariant scalar product on a Lie algebra  $\mathfrak{g}$  then the center  $\mathfrak{z}(\mathfrak{g})$  is contained in  $\mathfrak{g}'^\perp$ . If this scalar product is nondegenerate then  $\mathfrak{z}(\mathfrak{g}) = \mathfrak{g}'^\perp$ .

**Problem 9.** A semisimple Lie algebra (complex or real) coincides with its derived algebra. Any semisimple linear Lie algebra  $\mathfrak{g} \subset \mathfrak{gl}(V)$  is contained in the subalgebra  $\mathfrak{sl}(V)$  of traceless operators.

A complex linear Lie algebra  $\mathfrak{g}$  is called *reductive* if  $\mathfrak{g} = \mathfrak{z} \oplus \mathfrak{g}_1$  where  $\mathfrak{z}$  is a diagonalizable and  $\mathfrak{g}_1$  is a semisimple ideal of  $\mathfrak{g}$ . Clearly,  $\mathfrak{z}$  coincides with  $\mathfrak{z}(\mathfrak{g})$  and also with  $\text{rad } \mathfrak{g}$ . By Problem 9  $\mathfrak{g}_1$  coincides with the derived algebra  $\mathfrak{g}'$  of  $\mathfrak{g}$ . Problems 4, 7 and 8 imply that the scalar product (2) is nondegenerate on any reductive algebraic linear Lie algebra.

Now let  $\mathfrak{g}$  be an algebraic linear Lie algebra over  $\mathbb{C}$  such that the scalar product (2) is nondegenerate on it.

**Problem 10.** The center  $\mathfrak{z}(\mathfrak{g})$  of  $\mathfrak{g}$  is algebraic and consists of semisimple elements.

Problems 10, 4 and 8 imply that  $\mathfrak{g} = \mathfrak{z}(\mathfrak{g}) \oplus \mathfrak{g}'$ .

**Problem 11.**  $\mathfrak{g}'$  is semisimple.

Thus we have proved

**Theorem 2.** Let  $\mathfrak{g} \subset \mathfrak{gl}(V)$  be an algebraic linear Lie algebra over  $\mathbb{C}$ . The following conditions are equivalent:

- 1)  $\mathfrak{g}$  is a reductive algebraic linear Lie algebra;
- 2) the scalar product (2) is nondegenerate on  $\mathfrak{g}$ .

**2°. Algebraicity.** Let  $\mathfrak{g} \subset \mathfrak{gl}(V)$  be a semisimple linear Lie algebra over  $K = \mathbb{C}$  or  $\mathbb{R}$ . By Problem 8 and Corollary 1 of Theorem 3.3.3 (valid also over  $\mathbb{R}$  as had been mentioned in 3.3.8)  $\mathfrak{g}$  is an algebraic Lie algebra. This means that there exists an irreducible algebraic subgroup  $G \subset \text{GL}(V)$  with the tangent algebra  $\mathfrak{g}$ . For  $K = \mathbb{C}$  this subgroup is connected (see Theorem 3.3.1).

**Problem 12.** Any connected semisimple virtual Lie subgroup  $G \subset \text{GL}(V)$  is a Lie subgroup, which is algebraic if  $K = \mathbb{C}$  or which is the identity component of an irreducible algebraic linear group if  $K = \mathbb{R}$ .

A complex algebraic linear Lie group  $G$  is called *reductive* if its tangent algebra  $\mathfrak{g}$  is reductive. Problem 3.3.18 implies that this property of  $G$  does not depend on its representation as a linear group, so the notion of *reductive complex algebraic group* is well-defined. Any semisimple complex algebraic group is reductive. A reductive algebraic group  $G$  is semisimple if and only if  $\mathfrak{z}(\mathfrak{g}) = 0$ .

Theorem 2 implies that a complex algebraic linear group is reductive if and only if the scalar product (2) is nondegenerate on its tangent algebra.

**Problem 13.** The classical complex linear groups  $SL_n(\mathbb{C})$  ( $n \geq 2$ ),  $SO_n(\mathbb{C})$  ( $n \geq 3$ ),  $Sp_n(\mathbb{C})$  ( $n \geq 2$ ) are semisimple and  $GL_n(\mathbb{C})$  is reductive. All these groups are irreducible.

*Example.* Consider the real algebraic group  $SO_{k,l}$ , where  $k, l > 0$ ,  $k + l = n$ , consisting of unimodular matrices corresponding to linear operators preserving a nondegenerate quadratic form  $q$  of signature  $(k, l)$ . The group  $SO_{k,l}(\mathbb{C})$  is the group of unimodular complex matrices whose corresponding operators preserve  $q$ . Since all nondegenerate quadratic forms in  $\mathbb{C}^n$  are equivalent,  $SO_{k,l}(\mathbb{C})$  is isomorphic to  $SO_n(\mathbb{C})$ . Therefore  $SO_{k,l}$  is an irreducible semisimple algebraic group. At the same time it is not connected (see Problem 1.3.9).

Problem 9 and Theorem 1.4.1 imply that a connected semisimple Lie group coincides with its commutator group. Therefore (see Theorem 3.3.4) any differentiable representation of a connected semisimple complex algebraic group  $G$  is polynomial. By Theorem 3.3.5 the algebraic structure on  $G$  is unique. (Actually these statements are also true for arbitrary reductive algebraic groups over  $\mathbb{C}$ , see Exercise 10). In §3 we will show that any connected semisimple complex Lie group admits the structure of an algebraic group.

Let  $\mathfrak{g}$  be the tangent algebra of an algebraic group  $G$  over  $\mathbb{C}$ . Any commutative subalgebra of  $\mathfrak{g}$  consisting of semisimple elements is called *diagonalizable*.

**Problem 14.** An algebraic subalgebra  $\mathfrak{t} \subset \mathfrak{g}$  is diagonalizable if and only if it is the tangent algebra of a torus  $T \subset G$ . The maximal diagonalizable subalgebras are algebraic and correspond to maximal tori of  $G$ . If a maximal diagonalizable subalgebra  $\mathfrak{t}$  is zero then  $G^0$  is unipotent.

Two subalgebras of a Lie algebra  $\mathfrak{g}$  are *conjugate* if they are transformed into each other by an automorphism from  $\text{Int } \mathfrak{g}$ . Problems 14 and 3.2.24 imply that all maximal diagonalizable subalgebras of the tangent algebra of a complex algebraic group are conjugate.

The *rank of a reductive algebraic group*  $G$  (or of its *tangent algebra*  $\mathfrak{g}$ ) is the dimension of a maximal torus of  $G$  (or of a maximal diagonalizable subalgebra of  $\mathfrak{g}$ ) and is denoted by  $\text{rk } G = \text{rk } \mathfrak{g}$ .

**3°. Normal Subgroups.** We assume that the ground field  $K$  is either  $\mathbb{C}$  or  $\mathbb{R}$ . If  $\mathfrak{g}$  is *simple*, i.e. has no proper ideals, then either  $\mathfrak{g}$  is noncommutative or  $\mathfrak{g}$  is a one-dimensional commutative Lie algebra. Clearly, a noncommutative simple Lie algebra is semisimple.

Let  $\mathfrak{g}$  be a semisimple Lie algebra; we may consider it as a subalgebra of  $\mathfrak{gl}(V)$ , where  $V$  is a vector space over  $K$ .

**Problem 15.** On any ideal  $\mathfrak{a}$  of  $\mathfrak{g}$  the scalar product (2) is nondegenerate and  $\mathfrak{g} = \mathfrak{a} \oplus \mathfrak{a}^\perp$ . If  $\mathfrak{b}$  is an ideal of  $\mathfrak{a}$ , then  $\mathfrak{b}$  is also an ideal of  $\mathfrak{g}$ .

**Problem 16.** If  $\mathfrak{a}$  is an ideal of  $\mathfrak{g}$ , then  $\mathfrak{a}$  and  $\mathfrak{g}/\mathfrak{a}$  are semisimple.

**Problem 17.**  $\mathfrak{g}$  splits into the orthogonal direct sum of noncommutative simple ideals  $\mathfrak{g}_i$ , and any ideal of  $\mathfrak{g}$  is the sum of some of  $\mathfrak{g}_i$ 's.

Problem 15 and 17 imply

**Theorem 3.** *A semisimple Lie algebra splits uniquely into the direct sum of noncommutative simple ideals.*

The converse statement is also true:

**Problem 18.** If a Lie algebra  $\mathfrak{g}$  splits into the direct sum of noncommutative simple ideals then  $\mathfrak{g}$  is semisimple.

Now let us prove the corresponding results for Lie and algebraic groups.

A Lie group (in particular an algebraic group) is called *simple* if its tangent algebra is simple. By Problem 1.2.21 and Theorem 1.2, a connected Lie group  $G$  is simple if and only if  $G$  has no connected normal virtual Lie subgroups, not coinciding with  $\{e\}$  or  $G$ .

**Problem 19.** A connected simple Lie group or an irreducible simple algebraic group is either noncommutative and semisimple or commutative and one-dimensional.

**Problem 20.** A connected complex algebraic group  $G$  is simple if and only if it does not contain proper connected normal algebraic subgroups.

Let  $G$  be a Lie group,  $G_1, \dots, G_s$  its normal Lie subgroups. We say that  $G$  locally splits into the direct product of subgroups  $G_i$ 's if  $G = G_1 \dots G_s$  and all the intersections  $G_i \cap (G_1 \dots G_{i-1} G_{i+1} \dots G_s)$  ( $i = 1, \dots, s$ ) are discrete.

**Problem 21.** A connected Lie group  $G$  locally splits into the direct product of connected normal Lie groups  $G_i$ ,  $i = 1, \dots, s$ , if and only if its tangent algebra  $\mathfrak{g}$  splits into the direct sum  $\mathfrak{g} = \mathfrak{g}_1 \oplus \dots \oplus \mathfrak{g}_s$ , where  $\mathfrak{g}_i$  is the ideal tangent to  $G_i$ .

Theorem 3 and Problems 21, 18 imply

**Theorem 4.** *A connected semisimple Lie group  $G$  locally splits into the direct product of connected noncommutative simple normal Lie subgroups  $G = G_1 \dots G_s$ . Given such a decomposition, any normal Lie subgroup of  $G$  is a product of some of  $G_i$ 's. Any Lie group that locally splits into the direct product of noncommutative simple normal Lie subgroups is semisimple.*

**Problem 22.** A connected complex algebraic group  $G$  is reductive if and only if it locally splits into the direct product  $G = ZG_1$ , where  $Z$  is a torus and  $G_1$  is a semisimple normal subgroup. In this case  $Z$  coincides with  $Z(G)^0$  and with  $\text{Rad } G$ , whereas  $G_1$  coincides with the commutator group of  $G$ . A homomorphic image of a reductive group is a reductive group.

**4°. Weight and Root Decompositions.** From now on and till the end of the section we will assume that the ground field is  $\mathbb{C}$ . Algebraic tori will be briefly called tori.

Let  $T$  be a nontrivial torus,  $\mathfrak{t}$  its tangent algebra. As follows from Problem 3.3.2 the correspondence  $\lambda \mapsto d\lambda$  is an injective homomorphism of the group of characters of  $T$  into  $\mathfrak{t}^*$  sending any basis of the group  $\mathcal{X}(T)$  into a basis of the space  $\mathfrak{t}(\mathbb{R})^*$ , where  $\mathfrak{t}(\mathbb{R})$  is the real form of  $\mathfrak{t}$  defined by (3.3.2). It will be convenient for us to identify the characters  $\lambda \in \mathcal{X}(T)$  with their differentials. Then  $\mathcal{X}(T)$  is

identified with the discrete subgroup of the space  $t(\mathbb{R})^*$  generated by a basis of this space.

We may assume that the group  $T$  is linear. By Problem 2 the space  $t(\mathbb{R})$  is a Euclidean one with respect to the scalar product (2). Consider the canonical isomorphism  $\lambda \mapsto u_\lambda$  of  $t^*$  onto  $t$  defined by the formula

$$(u_\lambda, x) = \lambda(x) \quad (x \in t) \quad (3)$$

which maps  $t(\mathbb{R})^*$  onto  $t(\mathbb{R})$ . With this isomorphism we may translate the Euclidean space structure from  $t(\mathbb{R})$  into  $t(\mathbb{R})^*$  setting

$$(\lambda, \mu) = (u_\lambda, u_\mu) = \lambda(u_\mu) = \mu(u_\lambda) \quad (\lambda, \mu \in t(\mathbb{R})^*). \quad (4)$$

For any nonzero  $\lambda \in t(\mathbb{R})^*$  choose an element  $h_\lambda$  on the line  $\mathbb{C}u_\lambda \subset t(\mathbb{R})$ , such that  $\lambda(h_\lambda) = 2$ . Clearly,  $h_\lambda$  is uniquely defined, belongs to  $t(\mathbb{R})$  and is of the form

$$h_\lambda = 2u_\lambda/(\lambda, \lambda) \quad (5)$$

For any  $\mu \in t^*$  we have

$$\mu(h_\lambda) = 2(\mu, \lambda)/(\lambda, \lambda) \quad (6)$$

Now let  $G$  be an algebraic linear group containing a torus  $T$  and let  $R: G \rightarrow GL(V)$  be a polynomial linear representation. By Theorem 3.2.3 all the operators of  $R(T)$  are expressed in some basis by diagonal matrices. This means that

$$V = \bigoplus_{\lambda \in \Phi_R} V_\lambda, \quad (7)$$

where  $\Phi_R \subset \mathcal{X}(T)$  is the system of weights of the restriction  $R|T$ . The elements of the system  $\Phi_R$  will be called the weights of the representation  $R$  with respect to  $T$  and the decomposition (7) the weight decomposition with respect to  $T$ . Sometimes we write  $\Phi_R$  instead of  $\Phi_R(T)$ .

**Problem 23.** The system  $\Phi_R$  spans the subspace  $\{\lambda \in t(\mathbb{R})^*: \lambda(x) = 0 \text{ for all } x \in t \cap \text{Ker } dR\}$  in  $t(\mathbb{R})^*$ . In particular, if  $dR$  is faithful then  $\Phi_R$  spans  $t(\mathbb{R})^*$ .

Now take for  $R$  the adjoint representation  $\text{Ad}$  of  $G$  in its tangent algebra. For any  $\lambda \in \Phi_{\text{Ad}}$  we have

$$\mathfrak{g}_\lambda = \{x \in \mathfrak{g}: [h, x] = \lambda(h)x \text{ for all } h \in t\}. \quad (8)$$

In particular,  $\mathfrak{g}_0$  is the centralizer of the subalgebra  $t$  of  $\mathfrak{g}$  and therefore is an algebraic subalgebra containing  $t$ .

The nonzero weights of  $\Phi_{\text{Ad}}(T)$  are called roots and the weight subspaces  $\mathfrak{g}_\alpha$  ( $\alpha \neq 0$ ) root subspaces of  $\mathfrak{g}$  with respect to  $T$ . The root system is denoted by  $\Delta(T)$

or  $\Delta$ , hence  $\Phi_{\text{Ad}} = \Delta(T) \cup \{0\}$ . The decomposition

$$\mathfrak{g} = \mathfrak{g}_0 \oplus \bigoplus_{\alpha \in \Delta(T)} \mathfrak{g}_\alpha \quad (9)$$

is called the *root decomposition* of  $\mathfrak{g}$  with respect to  $T$ .

Let us study the action of automorphisms of  $G$  on weights and roots. Let  $\Theta \in \text{Aut } G$ ,  $\theta = d\Theta \in \text{Aut } \mathfrak{g}$ . The automorphism  $\Theta$  transforms  $T$  into  $\tilde{T} = \Theta(T)$ . By Problem 3.3.3 the isomorphism  $\theta: \mathfrak{t} \rightarrow \tilde{\mathfrak{t}}$  maps  $\mathfrak{t}(\mathbb{R})$  onto  $\tilde{\mathfrak{t}}(\mathbb{R})$  and therefore induces an isomorphism  $\theta': \tilde{\mathfrak{t}}(\mathbb{R})^* \rightarrow \mathfrak{t}(\mathbb{R})^*$ . We have  $\theta'(\mathcal{X}(\tilde{T})) = \mathcal{X}(T)$  and under the assumed identification of the character with its differential the obtained isomorphism of the groups of characters is identified with the isomorphism  $\lambda \mapsto \lambda \cdot \theta$ .

**Problem 24.** If  $\Theta = a(g)$ , where  $g \in G$ , then  $\theta' = {}'(\text{Ad } g)$  maps  $\Phi_R(\tilde{T})$  onto  $\Phi_R(T)$  and we have  $V_{i(\text{Ad } g)^{-1}\lambda} = R(g)V_\lambda$ . For any  $\Theta \in \text{Aut } G$  we have  $\theta'(\Delta(\tilde{T})) = \Delta(T)$  and  $\mathfrak{g}_{\theta^{-1}(\alpha)} = \theta(\mathfrak{g}_\alpha)$ .

**Problem 25.** For any representation  $R: G \rightarrow \text{GL}(V)$ , any  $\alpha \in \Phi_{\text{Ad}}(T)$ ,  $\lambda \in \Phi_R(T)$  and any  $x \in \mathfrak{g}_\alpha$  we have

$$dR(x)V_\lambda \begin{cases} \subset V_{\lambda+\alpha} & \text{if } \lambda + \alpha \in \Phi_R(T), \\ = 0 & \text{otherwise} \end{cases}$$

In particular, for any  $\alpha, \beta \in \Phi_{\text{Ad}}(T)$

$$[\mathfrak{g}_\alpha, \mathfrak{g}_\beta] \begin{cases} \subset \mathfrak{g}_{\alpha+\beta} & \text{if } \alpha + \beta \in \Phi_{\text{Ad}}(T) \\ = 0 & \text{otherwise.} \end{cases}$$

Now let us investigate the behavior of the root decomposition (9) with respect to the invariant scalar product (2).

**Problem 26.** If  $\alpha, \beta \in \Phi_{\text{Ad}}(T)$  and  $\alpha + \beta \neq 0$  then  $(\mathfrak{g}_\alpha, \mathfrak{g}_\beta) = 0$ .

**Problem 27.** Let  $G$  be a reductive algebraic group. Then the scalar product (2) is nondegenerate on  $\mathfrak{g}_0$ . If  $\alpha \in \Delta(T)$  then  $-\alpha \in \Delta(T)$  and the scalar product is nondegenerate on  $\mathfrak{g}_\alpha \oplus \mathfrak{g}_{-\alpha}$ .

**Problem 28.** If  $G$  is a reductive algebraic group then the subalgebra  $\mathfrak{g}_0$  is a reductive algebraic algebra. If, in particular,  $T$  is a maximal torus of  $G$  then  $\mathfrak{g}_0 = \mathfrak{t}$ .

Since all maximal tori in  $G$  are conjugate (Problem 3.2.24), Problem 24 implies that the weight system of a representation and the root system of  $G$  with respect to a maximal torus  $T$  are defined uniquely up to an isomorphism of the form  $\theta'(\text{Ad } g)$ , where  $g \in G$ , of the corresponding spaces  $\mathfrak{t}(\mathbb{R})^*$ . The roots with respect to a maximal torus  $T$  are simply called the *roots* of  $G$ ; the root system is denoted  $\Delta_G$  or  $\Delta_{\mathfrak{g}}$  since it is transparent from (8) that the root system is completely

determined by the pair  $(\mathfrak{g}, \mathfrak{t})$ . The root subspaces with respect to a maximal torus are simply called *root subspaces* of  $\mathfrak{g}$ .

In the sequel we assume that  $G$  is a reductive algebraic group and  $T$  is its maximal torus. The most interesting is the case when  $G$  is semisimple.

Let us present  $\mathfrak{g}$  in the form  $\mathfrak{g} = \mathfrak{z}(\mathfrak{g}) \oplus \mathfrak{g}'$ , where  $\mathfrak{g}'$  is a semisimple ideal. Problem 28 implies that any maximal diagonalizable subalgebra  $\mathfrak{t} \subset \mathfrak{g}$  contains  $\mathfrak{z}(\mathfrak{g})$  and therefore is of the form  $\mathfrak{t} = \mathfrak{z}(\mathfrak{g}) \oplus \mathfrak{t}'$ , where  $\mathfrak{t}' = \mathfrak{t} \cap \mathfrak{g}'$  is a maximal diagonalizable subalgebra of  $\mathfrak{g}'$ . Conversely, any subalgebra  $\mathfrak{t} = \mathfrak{z}(\mathfrak{g}) \oplus \mathfrak{t}_1$ , where  $\mathfrak{t}' = \mathfrak{t} \cap \mathfrak{g}'$  is a maximal diagonalizable subalgebra of  $\mathfrak{g}'$ , is a maximal diagonalizable subalgebra of  $\mathfrak{g}$ . Assigning to each linear function on  $\mathfrak{t}$  its restriction onto  $\mathfrak{t}'$  we identify the subspace  $\{\lambda \in \mathfrak{t}^*: \lambda(x) = 0 \text{ for all } x \in \mathfrak{z}(\mathfrak{g})\}$  with  $\mathfrak{t}'$ .

**Problem 29.** The root system  $\Delta_{\mathfrak{g}}$  is identified with  $\Delta_{\mathfrak{g}'}$  and  $\Delta_{\mathfrak{g}} = \Delta_{\mathfrak{g}'}$  spans the space  $\mathfrak{t}'(\mathbb{R})^*$  while the vectors  $h_{\alpha}$  ( $\alpha \in \Delta_{\mathfrak{g}}$ ) span  $\mathfrak{t}'_1(\mathbb{R})$ . The algebra  $\mathfrak{g}$  is commutative if and only if  $\Delta_{\mathfrak{g}} = \emptyset$  and semisimple if and only if  $\Delta_{\mathfrak{g}}$  spans  $\mathfrak{t}(\mathbb{R})^*$ .

**Problem 30.** For any  $x \in \mathfrak{g}_{\alpha}$ ,  $y \in \mathfrak{g}_{\alpha}$ , where  $\alpha \in \Delta_{\mathfrak{g}}$ , we have

$$[x, y] = (x, y)u_{\alpha} = \frac{1}{2}(x, y)(\alpha, \alpha)h_{\alpha}.$$

The subspace  $[\mathfrak{g}_{\alpha}, \mathfrak{g}_{-\alpha}]$  is one-dimensional and is spanned by  $h_{\alpha}$ .

It is clear from Problem 30 that the line  $\mathbb{C}h_{\alpha}$  for any given  $\alpha \in \Delta_{\mathfrak{g}}$  is determined by the Lie algebra structure on  $\mathfrak{g}$  and does not depend on the chosen realization of  $\mathfrak{g}$  as a linear Lie algebra. The definition of  $h_{\alpha}$  implies that it is also uniquely defined. If  $\mathfrak{g}$  is semisimple then by Problem 29 the space  $\mathfrak{t}(\mathbb{R})$  is generated by the elements  $h_{\alpha}$  ( $\alpha \in \Delta_{\mathfrak{g}}$ ). Therefore if  $\mathfrak{g}$  is semisimple,  $\mathfrak{t}(\mathbb{R})$  is completely determined by  $\mathfrak{g}$ .

Now let us investigate what is the root system of the direct sum  $\mathfrak{g} = \mathfrak{g}_1 \oplus \mathfrak{g}_2$ , where  $\mathfrak{g}_1, \mathfrak{g}_2$  are semisimple Lie algebras. From Problem 28 we easily deduce that any maximal diagonalizable subalgebra  $\mathfrak{t} \subset \mathfrak{g}$  is of the form  $\mathfrak{t} = \mathfrak{t}_1 \oplus \mathfrak{t}_2$ , where  $\mathfrak{t}_i$ ,  $i = 1, 2$ , is a maximal diagonalizable subalgebra of  $\mathfrak{g}_i$ . The converse is true since a subalgebra  $\mathfrak{t}$  of such a form coincides with its centralizer in  $\mathfrak{g}$ . Let us identify in a usual way  $\mathfrak{t}_1^*$  with the subspace  $\{\lambda \in \mathfrak{t}^*: \lambda(x) = 0 \text{ for all } x \in \mathfrak{t}_2\}$  and  $\mathfrak{t}_2^*$  with  $\{\lambda \in \mathfrak{t}^*: \lambda(x) = 0 \text{ for all } x \in \mathfrak{t}_1\}$ . Then  $\mathfrak{t}^* = \mathfrak{t}_1^* \oplus \mathfrak{t}_2^*$  and  $\mathfrak{t}(\mathbb{R})^* = \mathfrak{t}_1(\mathbb{R})^* \oplus \mathfrak{t}_2(\mathbb{R})^*$ . Let  $\Delta_{\mathfrak{g}}, \Delta_{\mathfrak{g}_1}, \Delta_{\mathfrak{g}_2}$  be the root systems of  $\mathfrak{g}, \mathfrak{g}_1, \mathfrak{g}_2$  with respect to  $\mathfrak{t}, \mathfrak{t}_1, \mathfrak{t}_2$ , respectively.

**Problem 31.** We have  $\Delta_{\mathfrak{g}} = \Delta_{\mathfrak{g}_1} \cup \Delta_{\mathfrak{g}_2}$  and  $(\alpha, \beta) = 0$  for any  $\alpha \in \Delta_{\mathfrak{g}_1}, \beta \in \Delta_{\mathfrak{g}_2}$ .

**Problem 32.** For any decomposition  $\Delta_{\mathfrak{g}} = \Delta_1 \cup \Delta_2$  of the root system of a semisimple Lie algebra  $\mathfrak{g}$  into a union of two orthogonal subsystems there exist ideals  $\mathfrak{g}_1, \mathfrak{g}_2 \subset \mathfrak{g}$  such that  $\mathfrak{g} = \mathfrak{g}_1 \oplus \mathfrak{g}_2$  and  $\Delta_i = \Delta_{\mathfrak{g}_i}$  ( $i = 1, 2$ ).

Concluding this section we generalize the notion of weight system and weight decomposition to an arbitrary linear representation  $\rho$  of a semisimple Lie algebra. We need this generalization since  $\rho$  need not a priori coincide with the differential

of a linear representation of any algebraic group whose tangent algebra is  $\mathfrak{g}$ . Note that this generalization does not actually give anything new since, as we shall see in §9, there always exists a simply connected algebraic group  $G$  with the tangent algebra  $\mathfrak{g}$  and  $\rho$  is the differential of a representation of  $G$  by Theorem 1.2.6.

Let  $\mathfrak{g}$  be a semisimple Lie algebra,  $G$  an algebraic group with  $\mathfrak{g}$  as the tangent algebra. Problems 3.3.18 and 3.3.20 applied to the adjoint representation of  $G$  yield that  $x \in \mathfrak{g}$  is semisimple (nilpotent) if and only if so is  $\text{ad } x$  in the space  $\mathfrak{g}$ . Therefore we may speak about *semisimple* and *nilpotent* elements of an abstract semisimple Lie algebra.

**Problem 33.** A linear representation  $\rho$  of a semisimple Lie algebra  $\mathfrak{g}$  maps the semisimple elements in semisimple operators and the nilpotent elements in nilpotent operators.

Let  $\rho: \mathfrak{g} \rightarrow \text{gl}(V)$  be a linear representation of a semisimple Lie algebra  $\mathfrak{g}$ ,  $\mathfrak{t}$  a maximal diagonalizable subalgebra of  $\mathfrak{g}$ . Problem 33 implies that  $\rho(\mathfrak{t})$  is a commutative subalgebra of  $\text{gl}(V)$  consisting of semisimple operators. By Problem 3.2.2 we have

$$V = \bigoplus_{\lambda \in \Phi_\rho} V_\lambda, \quad (10)$$

where

$$V_\lambda = \{u \in V: \rho(x)u = \lambda(x)u \text{ for all } x \in \mathfrak{t}\}$$

and  $\Phi_\rho \subset \mathfrak{t}^*$  is the set of linear functions  $\lambda$ , such that  $V_\lambda \neq 0$ . The elements of  $\Phi_\rho$  are called *weights* and the corresponding subspaces  $V_\lambda$  *weight subspaces* of the representation  $\rho$ . If  $\rho = dR$ , where  $R$  is a linear representation of  $G$ , then  $\Phi_\rho$  coincides with  $\Phi_R$  and the decomposition (10) with the weight decomposition (7). It is also easy to verify that the statement of Problem 25 holds for (10).

In 6° we will show that  $\Phi_\rho \subset \mathfrak{t}(\mathbb{R})^*$ .

**5°. Root Decompositions and Root Systems of Classical Lie Algebras.** In this section we will give explicitly the form of maximal diagonalizable subalgebras  $\mathfrak{t}_\mathfrak{g}$ , root decompositions, roots and vectors  $h_\alpha$  for the classical Lie algebras  $\mathfrak{g} = \text{gl}_n(\mathbb{C}), \mathfrak{sl}_n(\mathbb{C}), \mathfrak{so}_n(\mathbb{C}), \mathfrak{sp}_{2n}(\mathbb{C})$  (see Problem 13).

The identity, i.e. standard, representation of the corresponding classical group is denoted by  $\text{Id}$ ; it is convenient to express the roots by means of weights of  $\text{Id}$ .

Let  $T$  be the torus in  $\text{GL}_n(\mathbb{C})$  consisting of all invertible diagonal matrices. It is easy to verify that  $T$  coincides with its centralizer implying that  $T$  is a maximal torus of  $\text{GL}_n(\mathbb{C})$ . Its tangent algebra  $\mathfrak{t} \subset \text{gl}_n(\mathbb{C})$  is the algebra of all diagonal matrices and the real form  $\mathfrak{t}(\mathbb{R})$  is the algebra of all real diagonal matrices. The scalar product (2) is determined in  $\mathfrak{t}$  by the formula

$$(X, Y) = \sum_{1 \leq i \leq n} x_i y_i, \quad \text{where } X = \text{diag}(x_1, \dots, x_n), \quad Y = \text{diag}(y_1, \dots, y_n).$$

The vectors  $e_i$  ( $i = 1, \dots, n$ ) of the standard basis of  $\mathbb{C}^n$  are the weight vectors for the representation  $\text{Id}|T$ . The corresponding weight  $\varepsilon_i$  (and also the element  $d\varepsilon_i \in t(\mathbb{R})^*$  identified with it) is of the form

$$\varepsilon_i(\text{diag}(x_1, \dots, x_n)) = x_i \quad (i = 1, \dots, n). \quad (11)$$

In what follows  $\varepsilon_i$  also denotes the restriction of the linear function (11) onto the maximal diagonalizable subalgebra of a classical Lie algebra  $\mathfrak{g}$ .

*Example 4.* For  $\mathfrak{g} = \mathfrak{gl}_n(\mathbb{C})$  we have

$$t_{\mathfrak{g}} = t,$$

$$\Delta_{\mathfrak{g}} = \{\alpha_{ij} = \varepsilon_i - \varepsilon_j : i \neq j, i, j = 1, \dots, n\},$$

$$\mathfrak{g}_{\alpha_{ij}} = \mathbb{C}E_{ij},$$

$$h_{\alpha_{ij}} = \text{diag}(0, \dots, 0, 1, 0, \dots, 0, -1, 0, \dots, 0) \text{ with } 1 \text{ (resp. } -1) \text{ at the } i\text{-th (} j\text{-th) place.}$$

*Example 5.* For  $\mathfrak{g} = \mathfrak{sl}_n(\mathbb{C})$  ( $n \geq 2$ ) we have

$$t_{\mathfrak{g}} = \{x \in t : \text{tr } x = 0\},$$

$$\Delta_{\mathfrak{g}} = \{\alpha_{ij} = \varepsilon_i - \varepsilon_j : i \neq j, i, j = 1, \dots, n\}.$$

The subspaces  $\mathfrak{g}_{\alpha_{ij}}$  and vectors  $h_{\alpha_{ij}}$  are the same as in Example 4 (see Problem 29).

In the simplest case  $n = 2$  we have  $\Delta_{\mathfrak{g}} = \{\alpha, -\alpha\}$ , where  $\alpha = \alpha_{12}$ . A basis of the Lie algebra  $\mathfrak{sl}_2(\mathbb{C})$  is  $\{\mathbf{h}, \mathbf{e}, \mathbf{f}\}$ , where  $\mathbf{h} = h_{\alpha} = \text{diag}(1, -1)$ ,  $\mathbf{e} = E_{12}$ ,  $\mathbf{f} = E_{21}$  such that

$$[\mathbf{h}, \mathbf{e}] = 2\mathbf{e}, \quad [\mathbf{h}, \mathbf{f}] = -2\mathbf{f}, \quad [\mathbf{e}, \mathbf{f}] = \mathbf{h}.$$

In the following two examples we consider  $G = \text{SO}_n(\mathbb{C})$ . For our purposes it is convenient to choose a basis in  $\mathbb{C}^n$  so that the matrix of the  $G$ -invariant quadratic form is

$$\begin{pmatrix} 0 & E_l \\ E_l & 0 \end{pmatrix} \quad (n = 2l) \quad \text{or} \quad \begin{pmatrix} 0 & E_l & 0 \\ E_l & 0 & 0 \\ 0 & 0 & 1 \end{pmatrix} \quad (n = 2l + 1)$$

*Example 6.* The Lie algebra  $\mathfrak{g} = \mathfrak{so}_{2l}(\mathbb{C})$  ( $l \geq 2$ ) consists of matrices of the form

$$\begin{pmatrix} X & Y \\ Z & -X^T \end{pmatrix}, \quad X, Y, Z \in \mathfrak{gl}_l(\mathbb{C}), \quad Y^T = -Y, \quad Z^T = -Z.$$

We have

$$\mathfrak{t}_{\mathfrak{g}} = \{\text{diag}(x_1, \dots, x_l, -x_1, \dots, -x_l) : x_i \in \mathbb{C}\},$$

$$\Phi_{\text{Id}} = \{\varepsilon_1, \dots, \varepsilon_l, -\varepsilon_1, \dots, -\varepsilon_l\},$$

$$\Delta_{\mathfrak{g}} = \{\alpha_{ij} = \varepsilon_i - \varepsilon_j (i \neq j), \beta_{ij} = \varepsilon_i + \varepsilon_j (i < j), -\beta_{ij} : i, j = 1, \dots, l\},$$

$$\mathfrak{g}_{\alpha_{ij}} = \mathbb{C}(E_{ij} - E_{l+j, l+i}), \mathfrak{g}_{\beta_{ij}} = \mathbb{C}(E_{i, l+j} - E_{j, l+i}), \mathfrak{g}_{-\beta_{ij}} = \mathbb{C}(E_{l+i, j} - E_{l+j, i}).$$

$$h_{\alpha_{ij}} = \text{diag}(0, \dots, 0, 1, 0, \dots, 0, -1, 0, \dots, 0, -1, 0, \dots, 0, 1, 0, \dots, 0),$$

with entries 1 on the positions  $i, l + j$  and  $-1$  on the positions  $j, l + i$ ,

$$h_{\beta_{ij}} = \text{diag}(0, \dots, 0, 1, 0, \dots, 0, 1, 0, \dots, 0, -1, 0, \dots, 0, -1, 0, \dots, 0).$$

with entries 1 on the positions  $i, j$  and  $-1$  on the positions  $l + i, l + j$ .

*Example 7.* The Lie algebra  $\mathfrak{g} = \mathfrak{so}_{2l+1}(\mathbb{C})$  consists of the matrices of the form

$$\begin{pmatrix} X & Y & U \\ Z & -X^T & V \\ -V^T & -U^T & 0 \end{pmatrix}, \quad X, Y, Z \in \mathfrak{gl}_l(\mathbb{C}), Y^T = -Y, Z^T = -Z, U, V \in \mathbb{C}^l.$$

We have

$$\mathfrak{t}_{\mathfrak{g}} = \{\text{diag}(x_1, \dots, x_l, -x_1, \dots, -x_l, 0) : x_i \in \mathbb{C}\},$$

$$\Phi_{\text{Id}} = \{\varepsilon_1, \dots, \varepsilon_l, -\varepsilon_1, \dots, -\varepsilon_l, 0\},$$

$$\Delta_{\mathfrak{g}} = \{\alpha_{ij} = \varepsilon_i - \varepsilon_j (i \neq j), \beta_{ij} = \varepsilon_i + \varepsilon_j (i < j), -\beta_{ij}, \varepsilon_i, -\varepsilon_i : i, j = 1, \dots, l\},$$

$\mathfrak{g}_{\alpha_{ij}}, \mathfrak{g}_{\beta_{ij}}, \mathfrak{g}_{-\beta_{ij}}$  are determined by the same formulas as in Example 6.

$\mathfrak{g}_{\varepsilon_i} = \mathbb{C}(E_{i, 2l+1} - E_{2l+1, l+i}), \mathfrak{g}_{-\varepsilon_i} = \mathbb{C}(E_{l+i, 2l+1} - E_{2l+1, i}), h_{\alpha_{ij}}, h_{\beta_{ij}}$  are determined by the same formula as in Example 6,  $h_{\varepsilon_i} = \text{diag}(0, \dots, 2, 0, \dots, -2, 0, \dots, 0)$  with  $2(-2)$  on the  $i$ th ( $(l + i)$ -th) place.

For  $G = \text{Sp}_{2l}(\mathbb{C})$  we choose a basis in  $\mathbb{C}^{2l}$  such that the matrix of the invariant bilinear form is  $\begin{pmatrix} 0 & E_l \\ -E_l & 0 \end{pmatrix}$ .

*Example 8.* The Lie algebra  $\mathfrak{sp}_{2l}(\mathbb{C})$  ( $n \geq 1$ ) consists of matrices of the form

$$\begin{pmatrix} X & Y \\ Z & -X^T \end{pmatrix}, \quad X, Y, Z \in \mathfrak{gl}_l(\mathbb{C}), Y^T = Y, Z^T = Z.$$

The subalgebra  $\mathfrak{t}_{\mathfrak{g}}$  and the weight system  $\Phi_{\text{Id}}$  are the same as in Example 6. We have

$$\Delta_{\mathfrak{g}} = \{\alpha_{ij} = \varepsilon_i - \varepsilon_j (i \neq j), \beta_{ij} = \varepsilon_i + \varepsilon_j (i \leq j), -\beta_{ij} : i, j = 1, \dots, l\};$$

$\mathfrak{g}_{\alpha_{ij}}$ ,  $h_{\alpha_{ij}}$  and  $h_{\beta_{ij}}$  ( $-i < j$ ) are the same as in Example 6,  $\mathfrak{g}_{\beta_{ij}} = \mathbb{C}(E_{i,l+j} + E_{j,l+i})$ ,  $\mathfrak{g}_{-\beta_{ij}} = \mathbb{C}(E_{l+i,j} + E_{l+j,i})$ ,  $h_{\beta_{ii}} = \text{diag}(0, \dots, 0, 1, 0, \dots, 0, -1, 0, \dots, 0)$  with 1 (resp.  $-1$ ) at the  $i$ -th ( $(l+i)$ -th) place.

Note that  $\mathfrak{sp}_2(\mathbb{C}) = \mathfrak{sl}_2(\mathbb{C})$ .

**6°. Three-Dimensional Subalgebras.** We retain the notation of 4° and assume that  $G$  is reductive and  $T$  is a maximal torus of  $G$ . To each root  $\alpha \in \Delta_{\mathfrak{g}}$  we will assign a three-dimensional subalgebra of  $\mathfrak{g}$  isomorphic to  $\mathfrak{sl}_2(\mathbb{C})$ , a priori defined not quite uniquely. Let  $e_{\alpha}$  be a nonzero vector in  $\mathfrak{g}_{\alpha}$ . By Problem 27 there exists a nonzero vector  $e_{-\alpha} \in \mathfrak{g}_{-\alpha}$  such that  $(e_{\alpha}, e_{-\alpha}) = 2/(\alpha, \alpha)$ . Then (5) and (6) imply that

$$[e_{\alpha}, e_{-\alpha}] = h_{\alpha}, \quad [h_{\alpha}, e_{\alpha}] = 2e_{\alpha}, \quad [h_{\alpha}, e_{-\alpha}] = -2e_{-\alpha}.$$

Define the embedding  $\varphi_{\alpha}: \mathfrak{sl}_2(\mathbb{C}) \rightarrow \mathfrak{g}$  by setting (see Example 5):

$$\varphi_{\alpha}(\mathbf{e}) = e_{\alpha}, \quad \varphi_{\alpha}(\mathbf{f}) = e_{-\alpha}, \quad \varphi_{\alpha}(\mathbf{h}) = h_{\alpha}.$$

The map  $\varphi_{\alpha}$  is an isomorphism of  $\mathfrak{sl}_2(\mathbb{C})$  onto the subalgebra  $\mathfrak{g}^{(\alpha)} = \langle e_{\alpha}, e_{-\alpha}, h_{\alpha} \rangle \subset \mathfrak{g}$ .

By Problem 1.3.17 the group  $SL_2(\mathbb{C})$  is simply connected. Therefore (see Theorem 1.2.6) there exists a differentiable homomorphism  $F_{\alpha}: SL_2(\mathbb{C}) \rightarrow G$  such that  $dF_{\alpha} = \varphi_{\alpha}$ . Since  $SL_2(\mathbb{C})$  is semisimple,  $F_{\alpha}$  is a polynomial homomorphism. Its image is a connected algebraic subgroup  $G^{(\alpha)} \subset G$  with the tangent algebra  $\mathfrak{g}^{(\alpha)}$ .

**Problem 34.** For any  $\alpha \in \Delta_{\mathfrak{g}}$  we have  $h_{\alpha} \in t(\mathbb{Z})$ .

**Problem 35.** If  $\alpha, c\alpha \in \Delta_{\mathfrak{g}}$ , where  $c \in \mathbb{R}$ , then  $c = \pm 1/2, \pm 1$  or  $\pm 2$ .

Now consider the elements  $n_{\alpha} = F_{\alpha} \left( \begin{pmatrix} 0 & 1 \\ -1 & 0 \end{pmatrix} \right) \in G^{(\alpha)}$  ( $\alpha \in \Delta_{\mathfrak{g}}$ ).

**Problem 36.**  $(\text{Ad } n_{\alpha})h_{\alpha} = -h_{\alpha}$ ;  $(\text{Ad } n_{\alpha})x = x$ , if  $x \in t$  and  $\alpha(x) = 0$ .

**Problem 37.**  $n_{\alpha} T n_{\alpha}^{-1} = T$  and  $\text{Ad } n_{\alpha}$  induces in the space  $t(\mathbb{R})$  the orthogonal reflection  $r_{\alpha}$  with respect to the hyperplane  $P_{\alpha} = \{x \in t(\mathbb{R}): \alpha(x) = 0\}$ . The map  $r'_{\alpha}$  is the orthogonal reflection of  $t(\mathbb{R})^*$  with respect to the hyperplane  $L_{\alpha} = \{\lambda \in t(\mathbb{R})^*: (\alpha, \lambda) = 0\}$ .

This reflection will also be denoted by  $r_{\alpha}$ .

Problem 24 and 37 imply

**Theorem 5.** The weight system  $\Phi_R$  of any polynomial linear representation  $R: G \rightarrow GL(V)$  of a reductive algebraic group  $G$  is invariant with respect to the reflections  $r_{\alpha}$  ( $\alpha \in \Delta_G$ ). Moreover  $V_{r_{\alpha}(\lambda)} = R(n_{\alpha})V_{\lambda}$  for any  $\lambda \in \Phi_R$ . In particular,  $r_{\alpha}(\Delta_G) = \Delta_G$  and  $\mathfrak{g}_{r_{\alpha}(\beta)} = (\text{Ad } n_{\alpha})\mathfrak{g}_{\beta}$  for any  $\alpha, \beta \in \Delta_G$ .

**Corollary.** *The weight system  $\Phi_\rho$  of any linear representation  $\rho$  of  $\mathfrak{sl}_2(\mathbb{C})$  is symmetric: if  $\lambda \in \Phi_\rho$ , then  $-\lambda \in \Phi_\rho$ .*

We will use this corollary in the proof of the following important property of root decompositions.

**Theorem 6.** *The root subspaces of a reductive algebraic Lie algebra  $\mathfrak{g}$  are one-dimensional. If  $\alpha \in \Delta_{\mathfrak{g}}$ , then  $c\alpha \notin \Delta_{\mathfrak{g}}$  for  $c \in \mathbb{R}$  and  $c \neq \pm 1$ .*

*Proof.* Consider the subspace  $\mathfrak{m} = \tilde{\mathfrak{g}}_\alpha + \mathfrak{g}_{2\alpha} \subset \mathfrak{g}$ , where  $\tilde{\mathfrak{g}}_\alpha = \{x \in \mathfrak{g}_\alpha : (e_{-\alpha}, x) = 0\}$  and  $\mathfrak{g}_{2\alpha} = 0$  if  $2\alpha \notin \Delta_{\mathfrak{g}}$ .

**Problem 38.** The subspace  $\mathfrak{m}$  is invariant with respect to  $\text{ad } \mathfrak{g}^{(\alpha)}$ .

This problem and Corollary of Theorem 5 imply  $\mathfrak{m} = 0$  which proves Theorem 6.  $\square$

Theorem 6 shows, in particular, that  $\mathfrak{g}^{(\alpha)}$  is of the form

$$\mathfrak{g}^{(\alpha)} = \mathfrak{g}_\alpha + \mathfrak{g}_{-\alpha} + \mathbb{C}h_\alpha,$$

hence it is uniquely determined by the root  $\alpha$ .

Let  $\lambda \in \Phi_R$  and  $\alpha \in \Delta_G$ . The set of all weights of  $R$  of the form  $\lambda + k\alpha$ , where  $k \in \mathbb{Z}$ , is called the  $\alpha$ -string of weights through  $\lambda$ . Set

$$U = \bigoplus V_{\lambda+k\alpha},$$

where the sum runs through all the weights from the  $\alpha$ -string. Denote  $\rho = dR$ .

**Problem 39.** The subspace  $U$  is invariant with respect to the restriction of  $\rho$  onto  $\mathfrak{g}^{(\alpha)}$  and all  $V_{\lambda+k\alpha}$ 's are weight subspaces for  $\rho|_{\mathfrak{g}^{(\alpha)}}$  with respect to the diagonalizable subalgebra  $\langle h_\alpha \rangle$ .

**Problem 40.** The  $\alpha$ -string of weights through  $\lambda \in \Phi_R$  is of the form  $\{\lambda + k\alpha : k \in \mathbb{Z}, -p \leq k \leq q\}$ , where  $p, q$  are nonnegative integers and  $p - q = \lambda(h_\alpha)$ . If  $\lambda(h_\alpha) < 0$ , then  $\lambda + \alpha \in \Phi_R$  and if  $\lambda(h_\alpha) > 0$ , then  $\lambda - \alpha \in \Phi_R$ .

**Problem 41.** In notation of Problem 40  $\rho(e_\alpha)^{p+q}V_{\lambda-p\alpha} \neq 0$ . In particular, if  $\lambda + \alpha \in \Phi_R$ , then  $\rho(e_\alpha)V_\lambda \neq 0$ .

**Problem 42.** If  $\alpha, \beta, \alpha + \beta \in \Delta_{\mathfrak{g}}$ , then  $[\mathfrak{g}_\alpha, \mathfrak{g}_\beta] = \mathfrak{g}_{\alpha+\beta}$ .

Concluding this section we prove that the properties of the weight system  $\Phi_R$  listed above remain valid for the weight system  $\Phi_\rho$  of any linear representation  $\rho$  of a semisimple Lie algebra  $\mathfrak{g}$ , as defined in 4°. For this notice that  $\mathfrak{g} = \mathfrak{g}_1 \oplus \mathfrak{g}_2$ , where  $\mathfrak{g}_1, \mathfrak{g}_2$  are semisimple ideals,  $\mathfrak{g}_2 = \text{Ker } \rho$  and  $\rho$  isomorphically maps  $\mathfrak{g}_1$  onto  $\rho(\mathfrak{g})$ . Any maximal diagonalizable subalgebra  $\mathfrak{t}$  of  $\mathfrak{g}$  is of the form  $\mathfrak{t} = \mathfrak{t}_1 \oplus \mathfrak{t}_2$ , where  $\mathfrak{t}_i \subset \mathfrak{g}_i$ . By Problem 31  $\Delta_{\mathfrak{g}} = \Delta_{\mathfrak{g}_1} \cup \Delta_{\mathfrak{g}_2}$ . Clearly,  $\lambda(x) = 0$  if  $\lambda \in \Phi_\rho$  and  $x \in \mathfrak{t}_2 = \mathfrak{t} \cap \text{Ker } \rho$  implying  $\Phi_\rho \subset \mathfrak{t}_1^*$ . The set  $\Phi_\rho$  is identified with the weight system  $\Phi_{\rho_1}$ , where  $\rho_1 = \rho|_{\mathfrak{g}_1}$  is a faithful representation.

**Problem 43.** For any  $\lambda \in \Phi_\rho$  and  $\alpha \in \Delta_{\mathfrak{g}}$  we have  $\lambda(h_\alpha) \in \mathbb{Z}$ . In particular,  $\Phi_\rho \subset \mathfrak{t}(\mathbb{R})^*$ . The representation  $\rho$  is faithful if and only if  $\Phi_\rho$  spans  $\mathfrak{t}(\mathbb{R})^*$ .

Reducing the general case to the case of a faithful representation  $\rho$  and using Theorem 5, one proves easily that the system  $\Phi_\rho$  is invariant with respect to all reflections  $r_\alpha$ ,  $\alpha \in \Delta$ . This implies that for any representation  $\rho$  the assertions analogous to those of Problems 40 and 41 are true.

### Exercises

In exercises 1–13 the ground field is either  $\mathbb{C}$  or  $\mathbb{R}$  unless otherwise stated.

- 1) If  $\mathfrak{g} \subset \mathfrak{gl}(V)$  is an algebraic Lie algebra then the kernel of the scalar product (2) in  $\mathfrak{g}$  is the largest unipotent ideal. (This ideal is called the *unipotent radical* of  $\mathfrak{g}$ ).
- 2) In a simple Lie algebra any nonzero invariant scalar product is nondegenerate and all invariant scalar products are proportional.
- 3) Simple ideals of a Lie algebra are orthogonal with respect to any invariant scalar product.
- 4) In a diagonalizable complex algebraic linear Lie algebra the orthogonal complement to an algebraic subalgebra with respect to the form (2) is an algebraic subalgebra.
- 5) If  $\mathfrak{a}$  is an ideal of a Lie algebra  $\mathfrak{g}$ , then the restriction of the Cartan scalar product of  $\mathfrak{g}$  onto  $\mathfrak{a}$  coincides with the Cartan scalar product of  $\mathfrak{a}$ .
- 6) If  $(\mathfrak{g}, \mathfrak{g})_{\text{ad}} = 0$  then  $\mathfrak{g}$  is solvable. If  $\mathfrak{g}$  is solvable then  $(\mathfrak{g}, [\mathfrak{g}, \mathfrak{g}])_{\text{ad}} = 0$ .
- 7) If the Cartan scalar product of a Lie algebra  $\mathfrak{g}$  is nondegenerate then  $\mathfrak{g}$  is semisimple.
- 8) If  $\text{ad } \mathfrak{g}$  is an algebraic Lie algebra then the kernel of the Cartan scalar product of  $\mathfrak{g}$  is the largest nilpotent ideal of  $\mathfrak{g}$ .
- 9) Let  $W \subset V$  be a subspace, neither  $0$  nor  $V$ . The group

$$G = \{A \in \text{SL}(V): Av - v \in W \text{ for all } v \in V\}$$

is algebraic, connected and coincides with its commutator group but is not semisimple.

- 10) Any differentiable linear representation of a reductive complex algebraic group  $G$  is polynomial. Considered as a Lie group,  $G$  possesses a unique algebraic structure.
- 11) A normal Lie subgroup and a quotient of a semisimple Lie group are semisimple.
- 12) Let  $G = \prod_{1 \leq i \leq s} G_i$  be a decomposition of a connected semisimple Lie group  $G$  into a locally direct product of simple normal Lie subgroups. Then any normal Lie subgroup of  $G$  is the product of some of  $G_i$ 's by a central subgroup.
- 13) Any normal Lie subgroup of a connected normal Lie subgroup of a connected semisimple Lie group or a connected reductive algebraic group  $G$  is normal in  $G$ .
- 14) A connected complex algebraic group is reductive if and only if it locally splits into the direct product of connected simple normal algebraic subgroups with all the commutative factors isomorphic to  $\mathbb{C}^*$ .

- 15) A polynomial linear representation  $R$  of a reductive algebraic group is locally faithful if and only if the system  $\Phi_R$  generates  $\mathfrak{t}(\mathbb{R})^*$  (here  $\mathfrak{t}$  is the tangent algebra of the maximal torus with respect to which weights are considered).

In exercises 16–25  $G$  denotes a connected semisimple complex algebraic group and  $\mathfrak{g}$  its tangent algebra.

- 16) Let  $T$  be a torus in  $G$ ,  $\tilde{\mathfrak{g}}_0$  the orthogonal complement to  $\mathfrak{t}$  in  $\mathfrak{g}_0$ ,  $\alpha \in \Delta(T)$  and  $x \in \mathfrak{g}_\alpha$ ,  $x \neq 0$ . For the existence of an element  $y \in \mathfrak{g}_{-\alpha}$  such that  $[x, y] = h_\alpha$  it is necessary and sufficient that  $x \notin [\tilde{\mathfrak{g}}_0, x]$ .
- 17) For any  $x \in \mathfrak{g}$  the subspace  $[\mathfrak{g}, x]$  coincides with the orthogonal complement to the centralizer of  $x$ .
- 18) For any nilpotent  $x \in \mathfrak{g}$  there exists a semisimple  $y \in \mathfrak{g}$  such that  $[y, x] = x$ .
- 19) (*Morozov's theorem*). Any nilpotent  $x \in \mathfrak{g}$  can be included in a simple three-dimensional subalgebra. (Hint: choose a maximal torus  $T$  in the group  $N(x) = \{g \in G: (\text{Ad } g)x \in \langle x \rangle\}$ . Consider the root decomposition of  $\mathfrak{g}$  with respect to  $T$  and apply Exercise 16.)

A subalgebra of a Lie algebra  $\mathfrak{g}$  is *regular* if its normalizer contains the tangent algebra  $\mathfrak{t}$  of a maximal torus  $T \subset G$ . A subset  $\Sigma \subset \Delta_{\mathfrak{g}}$  is *closed* if for any  $\alpha, \beta \in \Sigma$  such that  $\alpha + \beta \in \Delta_{\mathfrak{g}}$  we have  $\alpha + \beta \in \Sigma$ .

- 20) Let  $\Sigma \subset \Delta_{\mathfrak{g}}$  be a closed subset,  $\mathfrak{t}_1 \subset \mathfrak{t}$  a subspace containing the vectors  $h_\alpha$  for all  $\alpha \in \Sigma$  such that  $-\alpha \in \Sigma$ . Then

$$\mathfrak{g}(\Sigma, \mathfrak{t}_1) = \mathfrak{t}_1 \oplus \bigoplus_{\alpha \in \Sigma} \mathfrak{g}_\alpha,$$

is a regular subalgebra of  $\mathfrak{g}$ .

- 21) Any regular subalgebra of  $\mathfrak{g}$  is conjugate to a subalgebra of the form  $\mathfrak{g}(\Sigma, \mathfrak{t}_1)$ .
- 22) The subalgebra  $\mathfrak{g}(\Sigma, \mathfrak{t}_1)$  is algebraic if and only if  $\mathfrak{t}_1$  is an algebraic subalgebra of  $\mathfrak{t}$ .
- 23) The subalgebra  $\mathfrak{g}(\Sigma, \mathfrak{t}_1)$  is reductive if and only if  $-\alpha \in \Sigma$  for any  $\alpha \in \Sigma$ . In this case the subalgebra is semisimple if and only if  $\mathfrak{t}_1$  is spanned by the vectors  $h_\alpha$ ,  $\alpha \in \Sigma$ .
- 24) The subalgebras  $\mathfrak{g}(\Sigma_1, \mathfrak{t}_1)$  and  $\mathfrak{g}(\Sigma_2, \mathfrak{t}_2)$  are conjugate if and only if there exists  $g \in G$  such that  $gTg^{-1} = T$ ,  $(\text{Ad } g)\mathfrak{t}_1 = \mathfrak{t}_2$  and  $(\text{Ad } g)\Sigma_2 = \Sigma_1$ .
- 25) Any subalgebra of  $\mathfrak{g}$  containing  $\mathfrak{t}$  coincides with its normalizer and therefore is a regular algebraic subalgebra.

In Exercises 26–28 a linear representation  $\rho: \mathfrak{g} \rightarrow \mathfrak{gl}(V)$  is considered.

- 26) If  $\tilde{V}_\lambda \subset V_\lambda$  is a subspace invariant with respect to  $\rho(e_\alpha)\rho(e_{-\alpha})$ , then  $\tilde{V}_\lambda \oplus (\bigoplus_{k>0} \rho(e_\alpha)^k \tilde{V}_\lambda) \oplus (\bigoplus_{l>0} \rho(e_{-\alpha})^l \tilde{V}_\lambda)$  is invariant with respect to  $\rho|_{\mathfrak{g}^{(\alpha)}}$ .
- 27) Let  $\lambda$  and  $\lambda + \alpha$ , where  $\alpha \in \Delta_{\mathfrak{g}}$ , be weights of  $\rho$  and  $A: V_\lambda \rightarrow V_{\lambda+\alpha}$  the linear map induced by  $\rho(e_\alpha)$ . Then
- if  $\lambda(h_\alpha) < 0$  then  $A$  is a monomorphism;
  - if  $\lambda(h_\alpha) \geq -1$  then  $A$  is an epimorphism.
- 28) Let  $v \in V_\lambda$  be an eigenvector of  $\rho(e_\alpha)\rho(e_{-\alpha})$  with eigenvalue  $c$ . Define  $p$  (resp.  $q$ ) as the maximal integer such that  $\rho(e_{-\alpha})^p v \neq 0$  (resp.  $\rho(e_\alpha)^q v \neq 0$ ). Then  $p - q = \lambda(h_\alpha)$  and  $c = p(q + 1)$ .

## Hints to Problems

1. Make use of Example 1 from 1.2 and Theorem 1.2.5.
4. Nondegeneracy follows from the positive definiteness on  $\mathfrak{t}(\mathbb{R})$  and the latter is obvious.
5. The first statement follows from Problem 4; to prove the second one consider  $[\mathfrak{n}, \mathfrak{n}]$ .
6. By Theorem 3.3.6

$$V_0 = \{v \in V: nv = 0\} \neq 0.$$

Clearly,  $V_0$  is  $\mathfrak{g}$ -invariant. The definition of  $V_0$  implies that

$$(X, Y) = \operatorname{tr}_{V/V_0}(XY) \quad \text{for } X \in \mathfrak{g}, Y \in \mathfrak{n}.$$

This makes it possible to apply induction on  $\dim V$ .

7. For  $K = \mathbb{C}$  apply Problem 5 to the kernel  $\mathfrak{n}$  of the scalar product (2). By Problem 2 this kernel is an ideal of  $\mathfrak{g}$ . For  $K = \mathbb{R}$  consider  $\mathfrak{g}(\mathbb{C})$  which is semisimple by Problem 1.4.
10. The semisimplicity of the elements of the center follows from Problem 6.
11. Let  $\mathfrak{n}$  be a solvable ideal in  $\mathfrak{g}' = [\mathfrak{g}, \mathfrak{g}]$ . Since  $\mathfrak{g}'$  is algebraic, then by passing to a solvable ideal  $\mathfrak{n}^a$  we may assume that  $\mathfrak{n}$  is an algebraic linear Lie algebra. Problem 6 implies that  $\mathfrak{n}$  is the tangent algebra of a torus. Problem 4 implies that  $\mathfrak{g}' = \mathfrak{n} \oplus \mathfrak{n}^\perp$  and  $[\mathfrak{n}, \mathfrak{n}^\perp] = 0$ . Therefore  $\mathfrak{n} \subset \mathfrak{z}(\mathfrak{g})$ , hence  $\mathfrak{n} = 0$ .
12. Make use of Corollary 2 of Theorem 1.2.7.
14. Notice that for any diagonalizable subalgebra  $\mathfrak{t} \subset \mathfrak{g}$  the algebraic subalgebra  $\mathfrak{t}^a$  is also diagonalizable. The last statement of the problem follows from Problem 6.
15. Apply Problem 5 to the ideal  $\mathfrak{n} = \mathfrak{a} \cap \mathfrak{a}^\perp$  of  $\mathfrak{g}$ . Then make use of the fact that  $[\mathfrak{a}, \mathfrak{a}^\perp] \subset \mathfrak{a} \cap \mathfrak{a}^\perp = 0$ .
17. The existence of the decomposition is proved by induction in  $\dim \mathfrak{g}$ . Let  $\mathfrak{g}_1$  be a minimal ideal of  $\mathfrak{g}$ . Problem 15 implies that  $\mathfrak{g}_1$  is simple and  $\mathfrak{g} = \mathfrak{g}_1 \oplus \mathfrak{g}_1^\perp$ . It is clear from Problem 16 that  $\mathfrak{g}_1^\perp$  is a semisimple ideal which enables us to apply to it the inductive hypothesis. To prove the second statement notice that the projection  $\mathfrak{h}_i$  of any ideal  $\mathfrak{h}$  of  $\mathfrak{g}$  onto  $\mathfrak{g}_i$  is an ideal of  $\mathfrak{g}_i$ ; therefore either  $\mathfrak{h}_i = 0$  or  $\mathfrak{h}_i = \mathfrak{g}_i$ . But in the second case  $\mathfrak{g}_i = [\mathfrak{g}_i, \mathfrak{h}] \subset \mathfrak{h}$ .
20. Let  $G$  satisfy the conditions of the theorem and  $\mathfrak{h}$  be a nonzero ideal of its tangent algebra  $\mathfrak{g}$ . Then  $\mathfrak{g}^a$  is an ideal of  $\mathfrak{g}$  (Problem 3.3.9). Therefore  $\mathfrak{h}^a = \mathfrak{g}$  implying  $\mathfrak{g}' = \mathfrak{h}' \subset \mathfrak{h}$  by Theorem 3.3.3. Since  $\mathfrak{g}'$  is an algebraic ideal of  $\mathfrak{g}$ , then either  $\mathfrak{g}' = \mathfrak{g}$  (and hence  $\mathfrak{h} = \mathfrak{g}$ ) or  $\mathfrak{g}' = 0$ . In the second case the description of connected commutative algebraic groups (see Corollary of Theorem 3.2.8) implies that  $\dim \mathfrak{g} = 1$ ; therefore  $\mathfrak{h} = \mathfrak{g}$ .
21. First, prove that  $ab = ba$  for any  $a \in G_i, b \in G_j, i \neq j$ . Then consider the homomorphism  $m: G_1 \times \cdots \times G_s \rightarrow G$  defined by the formula  $m(g_1, \dots, g_s) = g_1 \dots g_s$  and apply Problem 1.3.11.

23. Note that  $\mathfrak{t} \cap \text{Ker } dR$  coincides with the intersection of the kernels  $\text{Ker } \lambda$  for all  $\lambda \in \Phi_R$ .
26. Follows from the invariance of the scalar product with respect to  $\text{Ad } T$ .
27. Follows from Problems 26 and 7.
28. The algebraic Lie algebra  $\mathfrak{g}_0$  is reductive thanks to Theorem 1 and Problem 27. We have  $\mathfrak{t} \subset \mathfrak{z}(\mathfrak{g}_0)$ . If  $T$  is a maximal torus then  $\mathfrak{t} = \mathfrak{z}(\mathfrak{g}_0)$  so that  $\mathfrak{g}_0 = \mathfrak{t} \oplus \mathfrak{g}'_0$ , where  $\mathfrak{g}'_0$  is the semisimple ideal of  $\mathfrak{g}_0$ . If  $\mathfrak{g}'_0 \neq 0$ , then  $\mathfrak{g}'_0$  contains a nonzero semisimple element (see Corollary 2 of Theorem 3.3.6) contradicting the maximality of the diagonalizable subalgebra  $\mathfrak{t}$ .
29. Make use of Problem 23.
31. To prove the orthogonality note that  $\alpha(h_\beta) = 0$  if  $\alpha$  and  $\beta$  belong to different  $\Delta_{\mathfrak{g}_i}$  ( $i = 1, 2$ ).
32. If  $\alpha \in \Delta_1$ ,  $\beta \in \Delta_2$  then  $(\alpha + \beta, \alpha) > 0$ ,  $(\alpha + \beta, \beta) > 0$  implying  $\alpha + \beta \notin \Delta_{\mathfrak{g}}$ . Therefore the subspaces  $\mathfrak{g}_i = \mathfrak{t}_i \oplus \bigoplus_{\alpha \in \Delta_i} \mathfrak{g}_\alpha$ , where  $\mathfrak{t}_i$  is the linear span of all  $h_\alpha$  such that  $\alpha \in \Delta_i$ , satisfy  $[\mathfrak{g}_1, \mathfrak{g}_2] = 0$  and  $\mathfrak{g}_i$  are subalgebras such that  $\mathfrak{g} = \mathfrak{g}_1 \oplus \mathfrak{g}_2$  and  $\Delta_{\mathfrak{g}_i} = \Delta_i$  ( $i = 1, 2$ ).
33. The statement is obvious if  $\rho$  is a faithful representation. It is easy to verify that the projection of  $\mathfrak{g}$  onto any direct summand maps the semisimple elements into semisimple ones and the nilpotent elements into nilpotent ones. By Problems 15, 16  $\mathfrak{g}$  decomposes as  $\mathfrak{g} = \mathfrak{g}_1 \oplus \mathfrak{g}_2$ , where  $\mathfrak{g}_i$  are semisimple ideals,  $\mathfrak{g}_2 = \text{Ker } \rho$  and  $\rho_1 = \rho|_{\mathfrak{g}_1}$  is a faithful representation. We have  $\rho = \rho_1 \circ \pi$ , where  $\pi: \mathfrak{g} \rightarrow \mathfrak{g}_1$  is the projection.
34. Notice that  $\mathfrak{h} \in \mathfrak{t}(\mathbb{Z})$  for  $\text{SL}_2(\mathbb{C})$  and that for any homomorphism of tori  $\varphi: T \rightarrow \tilde{T}$  we have  $d\varphi(\mathfrak{t}(\mathbb{Z})) \subset \mathfrak{t}(\mathbb{Z})$ .
35. If  $\alpha, c\alpha \in \Delta_{\mathfrak{g}}$ , where  $c \in \mathbb{R}$ , then Problem 34 implies that  $2/c, 2c \in \mathbb{Z}$ .
36. The first statement follows from the identity  $\begin{pmatrix} 0 & 1 \\ -1 & 0 \end{pmatrix} h \begin{pmatrix} 0 & 1 \\ -1 & 0 \end{pmatrix}^{-1} = -h$ .  
To prove the second statement note that if  $\alpha(x) = 0$ , then  $[\mathfrak{g}^{(\alpha)}, x] = 0$ , hence  $(\text{Ad } g)x = x$  for any  $g \in G^{(\alpha)}$ .
40. Let  $r \leq s$  be integers such that  $\lambda + k\alpha \in \Phi_R$  for all integers  $k$ ,  $r \leq k \leq s$ , but  $\lambda + (r-1)\alpha \notin \Phi_R$  and  $\lambda + (s+1)\alpha \notin \Phi_R$ . Then  $\tilde{U} = \bigoplus_{r \leq k \leq s} V_{\lambda+k\alpha}$  is invariant with respect to  $\rho|_{\mathfrak{g}^{(\alpha)}}$ . Applying Corollary of Theorem 5 we see that the set of numbers  $\{\lambda(h_\alpha) + 2k : r \leq k \leq s\}$  is symmetric with respect to zero. Therefore  $\lambda(k_\alpha) = -(r+s)$  and the segment  $\{\lambda + k\alpha : r \leq k \leq s\}$  of our  $\alpha$ -string is symmetric. There are no other weights in the  $\alpha$ -string since any of its segments is symmetric and therefore intersects with the one already considered.
41. Let  $s \geq 0$  be the minimal of integers  $k$  such that  $\rho(e_\alpha)V_{\lambda-k\alpha} \neq 0$ . Verify that  $U = \bigoplus_{0 \leq k \leq s} \rho(e_\alpha)^k V_{\lambda-k\alpha}$  is invariant with respect to  $\rho|_{\mathfrak{g}^{(\alpha)}}$ . If  $s < p+q$  then the weight system of the subrepresentation of  $G^{(\alpha)}$  in  $U$  is not symmetric.
42. Apply Problem 41 to the adjoint representation.
43. If  $\rho$  is faithful then it may be replaced by the identity representation of  $\rho(\mathfrak{g})$  in which case Problem 34 is applicable. This and the above arguments imply that in general case  $\lambda(h_\alpha) \in \mathbb{Z}$  for all  $\lambda \in \Phi_\rho$  and all  $\alpha \in \Delta_{\mathfrak{g}_1}$ . Besides,  $\lambda(h_\alpha) = 0$  for all  $\alpha \in \Delta_{\mathfrak{g}_2}$ .

## §2. Root Systems

In 1.4° we have introduced the root system of a reductive (in particular, semisimple) algebraic group. In this section this notion will be axiomized and studied in detail. The exposition of the properties of an abstract root systems is intermitted with interpretation of these properties in the language of algebraic groups and Lie algebras. The ground field is  $\mathbb{C}$ .

**1°. Principal Definitions and Examples.** Let  $\mathbf{E}$  be a finite-dimensional Euclidean space with the scalar product  $(\cdot, \cdot)$ . For an arbitrary nonzero vector  $\alpha \in \mathbf{E}$  denote by  $L_\alpha$  the hyperplane of  $\mathbf{E}$  orthogonal to  $\alpha$  and by  $r_\alpha$  the reflection with respect to  $L_\alpha$ . To express  $r_\alpha$  explicitly set

$$\langle \lambda | \mu \rangle = 2(\lambda, \mu) / (\mu, \mu) \quad (\lambda, \mu \in \mathbf{E}, \mu \neq 0).$$

Note that the function  $\langle \lambda | \mu \rangle$  is linear only in the first argument and does not vary if the scalar product in  $\mathbf{E}$  is multiplied by a positive number.

**Problem 1.** The reflection  $r_\alpha$  acts by the formula

$$r_\alpha(\beta) = \beta - \langle \beta | \alpha \rangle \alpha \quad (\beta \in \mathbf{E}).$$

A subset  $\Delta \subset \mathbf{E}$  is a *root system* in  $\mathbf{E}$  if it has the following properties:

- 1)  $\Delta$  is finite and consists of nonzero vectors;
- 2) for any  $\alpha \in \Delta$  the reflection  $r_\alpha$  transforms  $\Delta$  into itself;
- 3)  $\langle \alpha | \beta \rangle \in \mathbb{Z}$  for any  $\alpha, \beta \in \Delta$ .

The *rank*  $\text{rk } \Delta$  of a root system  $\Delta$  is, as usual, the dimension of its linear span.

By 2) we have  $-\alpha = r_\alpha(\alpha) \in \Delta$  for any  $\alpha \in \Delta$ . A root system  $\Delta$  is *reduced* if

- 4)  $\alpha \in \Delta$  and  $c\alpha \in \Delta$  for some  $c \in \mathbb{R}$  imply  $c = \pm 1$ .

**Problem 2.** Let  $\Delta$  be a root system,  $\alpha \in \Delta$  and  $c\alpha \in \Delta$  for some  $c \in \mathbb{R}$ . Then  $c = \pm 1/2, \pm 1, \pm 2$ .

Let  $G$  be a reductive algebraic group,  $T$  its maximal torus. In 1.4° the root system  $\Delta_G$  of  $G$  with respect to  $T$  (or, which is the same, the root system  $\Delta_{\mathfrak{g}}$  of the Lie algebra  $\mathfrak{g}$ ) was defined. This is a system of vectors of the Euclidean space  $\mathbf{E} = \mathfrak{t}(\mathbb{R})^*$ . By Problem 1.34 and Theorems 1.5, 1.6  $\Delta_G$  is a reduced root system in the sense of the above definition. The group  $G$  is semisimple if and only if  $\Delta_G$  spans  $\mathbf{E}$ ;  $G^0$  is a torus if and only if  $\Delta_G = \emptyset$  (see Problem 1.29). In the general case  $\text{rk } \Delta_{\mathfrak{g}} = \text{rk } \mathfrak{g}'$ .

We will prove that any nonempty reduced root system is (naturally) isomorphic to a root system of a semisimple algebraic group. We will encounter nonreduced root systems in Ch.V.

Let  $\Omega$  and  $\Omega'$  be two sets of vectors of Euclidean spaces  $\mathbf{E}$  and  $\mathbf{E}'$  respectively. An *isomorphism* of  $\Omega$  onto  $\Omega'$  is any linear isomorphism  $\varphi: \langle \Omega \rangle \rightarrow \langle \Omega' \rangle$  of their

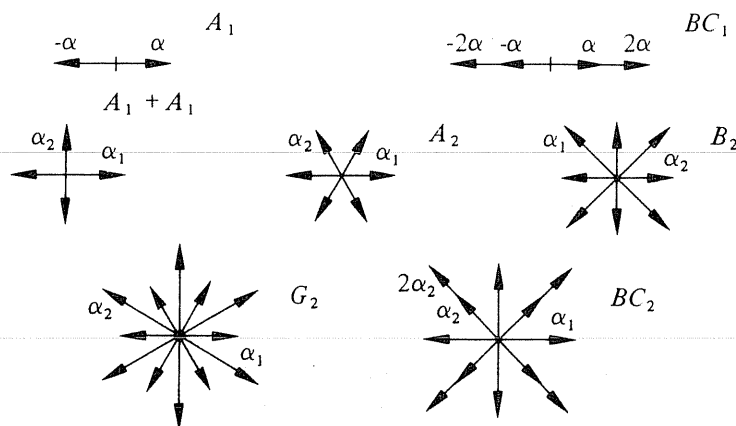

Fig. 1

linear spans such that  $\varphi(\Omega) = \Omega'$  and  $\langle \varphi(\alpha), \varphi(\beta) \rangle = \langle \alpha | \beta \rangle$  ( $\alpha, \beta \in \Omega$ ). The map  $\varphi$  need not be orthogonal (e.g. any homothety  $\alpha \mapsto c\alpha$ ,  $c \neq 0$ , of  $\mathbb{E}$  defines an isomorphism of  $\Omega$  onto  $c\Omega$ ). Clearly an isomorphism  $\varphi: \langle \Omega \rangle \rightarrow \langle \Omega' \rangle$  is completely determined by the map  $\varphi|_{\Omega}: \Omega \rightarrow \Omega'$ . In particular, we may speak about an isomorphism of root systems and isomorphic root systems. The isomorphisms of a set  $\Omega$  onto itself are its *automorphisms*; they form the group  $\text{Aut } \Omega$ .

Consider the root system  $\Delta_{\mathfrak{g}}(\mathfrak{t})$  of a semisimple Lie algebra  $\mathfrak{g}$  with respect to a maximal diagonalizable subalgebra  $\mathfrak{t}$ . As we have seen in 1.4°, the vector space  $\mathbb{E} = \mathfrak{t}(\mathbb{R})^*$  is uniquely determined by  $(\mathfrak{g}, \mathfrak{t})$ . The scalar product in  $\mathbb{E}$  depends, in general, on the realization of  $\mathfrak{g}$  as an algebra of linear transformations. The numbers  $\langle \alpha | \beta \rangle$  ( $\alpha, \beta \in \Delta_{\mathfrak{g}}$ ), however, are only defined by the structure of  $\mathfrak{g}$ , i.e. do not depend on the choice of this realization (see 1.4°). Furthermore, if we replace  $\mathfrak{t}$  by another maximal diagonalizable subalgebra  $\tilde{\mathfrak{t}}$  then by Problem 1.24 the corresponding root system  $\Delta_{\mathfrak{g}}(\tilde{\mathfrak{t}})$  is obtained from  $\Delta_{\mathfrak{g}}(\mathfrak{t})$  via  $(\text{Ad } g)^{-1}: \mathfrak{t}(\mathbb{R}) \rightarrow \tilde{\mathfrak{t}}(\mathbb{R})$ , where  $g$  is an element of  $G^\circ$ . The invariance of the scalar product implies that  $(\text{Ad } g)^{-1}$  is orthogonal, i.e. is an isomorphism of the root systems.

Now let  $\mathfrak{g}$  be a reductive algebraic Lie algebra,  $\mathfrak{t}$  its maximal diagonalizable subalgebra. By Problem 1.23 the root system  $\Delta_{\mathfrak{g}}$  spans the subspace  $\{\lambda \in \mathfrak{t}(\mathbb{R})^*: \lambda(x) = 0 \text{ for all } x \in \mathfrak{z}(\mathfrak{g}) \cap \mathfrak{t}(\mathbb{R})\}$  of  $\mathfrak{t}(\mathbb{R})^*$ . In Problem 1.29 we have identified  $\Delta_{\mathfrak{g}}$  with  $\Delta_{\mathfrak{g}^\circ}$ . Clearly, this identification is an isomorphism of the root systems.

Examples of root systems of rank 1 and 2 are depicted in Fig. 1.

**Problem 3.** All the vector systems depicted in Fig. 1 are root systems and all of them, except for  $BC_1$  and  $BC_2$  are reduced and nonisomorphic. The root systems of types  $A_1, A_2, A_1 + A_1, B_2$  are isomorphic to the root systems of Lie algebras  $\mathfrak{sl}_2(\mathbb{C}), \mathfrak{sl}_3(\mathbb{C}), \mathfrak{so}_4(\mathbb{C})$  (or  $\mathfrak{so}_3(\mathbb{C}), \mathfrak{so}_5(\mathbb{C}), \mathfrak{sl}_2(\mathbb{C}) \oplus \mathfrak{sl}_2(\mathbb{C})$ ), and  $\mathfrak{sp}_4(\mathbb{C})$  respectively (see Examples 5.8 of 1.5°).

**Problem 4.** The systems  $A_1$  and  $BC_2$  are the only up to an isomorphism root systems of rank 1.

We will see that any root system of rank 2 is isomorphic to one of the systems depicted in Fig. 1.

**Problem 5.** Let  $\Delta_i \subset E_i$  ( $i = 1, \dots, s$ ) be root systems and  $E = \bigoplus_{1 \leq i \leq s} E_i$  the orthogonal direct sum of Euclidean spaces  $E_i$ . Then  $\Delta = \bigcup_{1 \leq i \leq s} \Delta_i$  is a root system in  $E$ .

The system  $\Delta$  constructed in Problem 5 is called the *direct sum of root systems*  $\Delta_i$  ( $i = 1, \dots, s$ ). For example, by Problem 1.31 the root system  $\Delta_{\mathfrak{g}_1 \oplus \mathfrak{g}_2}$  of the direct sum of semisimple Lie algebras is the direct sum of  $\Delta_{\mathfrak{g}_1}$  and  $\Delta_{\mathfrak{g}_2}$ .

A system of nonzero vectors  $\Omega \subset E$  is *indecomposable* if it cannot be presented as the union  $\Omega = \Omega_1 \cup \Omega_2$  of two proper subsets, orthogonal to each other; otherwise  $\Omega$  is called *decomposable*. Clearly, all the root systems expressed on Fig. 1 except  $A_1 + A_1$  are indecomposable.

**Problem 6.** For an arbitrary root system  $\Delta \subset E$  there exists an orthogonal direct decomposition  $E = \bigoplus_{1 \leq i \leq s} E_i$  such that  $\Delta = \bigcup_{1 \leq i \leq s} \Delta_i$ , where  $\Delta_i \subset E_i$  ( $i = 1, \dots, s$ ) are indecomposable root systems.

The subsystems  $\Delta_i$  are maximal indecomposable subsystems in  $\Delta$  and therefore are determined uniquely.

The systems  $\Delta_i$  mentioned in Problem 6 are called *indecomposable components* of  $\Delta$ . Obviously,  $\Delta$  is the direct sum of its indecomposable components.

**Problem 7.** The root system  $\Delta_{\mathfrak{g}}$  of a semisimple Lie algebra  $\mathfrak{g}$  is indecomposable if and only if  $\mathfrak{g}$  is simple. If  $\mathfrak{g} = \bigoplus_{1 \leq i \leq s} \mathfrak{g}_i$  is a decomposition of  $\mathfrak{g}$  into the direct sum of simple ideals then  $\Delta_{\mathfrak{g}} = \bigcup_{1 \leq i \leq s} \Delta_{\mathfrak{g}_i}$  is a decomposition of  $\Delta_{\mathfrak{g}}$  into the direct sum of indecomposable components.

Now let us study the simplest geometric properties of root systems. The axiom 3) imposes rigorous constraints on the possible angles between roots and the ratios of their lengths.

**Problem 8.** Let  $\alpha, \beta$  be nonzero vectors of a Euclidean space  $E$  and  $\theta$  the angle between  $\alpha$  and  $\beta$ . Then  $\langle \alpha | \beta \rangle \langle \beta | \alpha \rangle = 4 \cos^2 \theta$ . If  $\langle \alpha | \beta \rangle$  and  $\langle \beta | \alpha \rangle$  are nonpositive integers and  $|\beta| \geq |\alpha|$  then for  $\theta, \langle \alpha | \beta \rangle, \langle \beta | \alpha \rangle, |\beta|^2/|\alpha|^2$  only the following values are possible:

$\theta$	$\langle \alpha   \beta \rangle$	$\langle \beta   \alpha \rangle$	$ \beta ^2/ \alpha ^2$
$\pi/2$	0	0	
$2\pi/3$	-1	-1	1
$3\pi/4$	-1	-2	2
$5\pi/6$	-1	-3	3
$\pi$	-2	-2	1
$\pi$	-1	-4	4

**Problem 9.** Let  $\alpha, \beta$  be two nonproportional roots from  $\Delta$ . If  $(\alpha, \beta) > 0$  then  $\alpha - \beta \in \Delta$  and if  $(\alpha, \beta) < 0$  then  $\alpha + \beta \in \Delta$ .

Let  $\alpha, \beta$  be two nonproportional elements from a root system  $\Delta$ . The set  $\{\gamma \in \Delta: \gamma = \beta + k\alpha (k \in \mathbb{Z})\}$  is called the  $\alpha$ -string through  $\beta$ .

**Problem 10.** The  $\alpha$ -string through  $\beta$  is of the form  $\{\beta + k\alpha: -p \leq k \leq q\}$ , where  $p, q \geq 0$  and  $p - q = \langle \beta, \alpha \rangle$ . In particular, if  $\beta - \alpha \notin \Delta$ , then  $\beta + \alpha \in \Delta$  if and only if  $\langle \beta, \alpha \rangle < 0$ .

In conclusion of this subsection let us construct the *dual* root system. Let  $\mathbf{E}$  be a finite-dimensional Euclidean space and  $\mathbf{F} = \mathbf{E}^*$  its dual. Let us identify  $\mathbf{F}^*$  with  $\mathbf{E}$  with the help of the natural isomorphism  $\mathbf{E} \rightarrow (\mathbf{E}^*)^* = \mathbf{F}^*$ , i.e. consider  $\mathbf{E}$  as the dual of  $\mathbf{F}$ . Let  $\lambda \mapsto u_\lambda$  be the isomorphism of vector spaces  $\mathbf{E} \rightarrow \mathbf{F}$  defined by the scalar product in  $\mathbf{E}$ , i.e. given by the formula

$$\lambda(u_\mu) = (\lambda, \mu) \quad (\lambda, \mu \in \mathbf{E}).$$

Let us translate the Euclidean space structure onto  $\mathbf{F}$  with the help of this isomorphism setting

$$(u_\lambda, u_\mu) = (\lambda, \mu) = \lambda(u_\mu) = \mu(u_\lambda) \quad (\lambda, \mu \in \mathbf{E}).$$

Let  $\Delta$  be a root system in  $\mathbf{E}$ . For any  $\alpha \in \Delta$  set

$$\alpha^\vee = 2u_\alpha/(\alpha, \alpha)$$

Then

$$\mu(\alpha^\vee) = 2(\mu, \alpha)/(\alpha, \alpha) = \langle \mu | \alpha \rangle \quad (\mu \in \mathbf{E}).$$

In particular by Problem 1

$$r_\alpha(\lambda) = \lambda - \lambda(\alpha^\vee)\alpha \quad (\lambda \in \mathbf{E}).$$

It is easy to verify that

$$\langle \alpha^\vee | \beta^\vee \rangle = \langle \beta | \alpha \rangle \quad \text{for any } \alpha, \beta \in \Delta. \quad (1)$$

**Problem 11.** If  $\Delta$  is a root system in  $\mathbf{E}$  then  $\Delta^\vee = \{\alpha^\vee: \alpha \in \Delta\}$  is a root system in  $\mathbf{F}$ , reduced if and only if so is  $\Delta$ . We have

$$\text{rk } \Delta = \text{rk } \Delta^\vee, \quad (\Delta^\vee)^\vee = \Delta.$$

The root system  $\Delta^\vee$  is called the *dual* of  $\Delta$ .

In particular, let  $\mathbf{E} = \mathfrak{t}(\mathbb{R})^*$ , where  $\mathfrak{t}$  is a maximal diagonalizable subalgebra of a reductive algebraic linear Lie algebra  $\mathfrak{g}$  (see 1.4°). Then  $\mathbf{F} = \mathfrak{t}(\mathbb{R})$  and the root system dual to  $\Delta_{\mathfrak{g}}$  is the system  $\Delta_{\mathfrak{g}}^\vee = \{h_\alpha: \alpha \in \Delta_{\mathfrak{g}}\}$ .

**2°. Weyl Chambers and Simple Roots.** Let  $\Delta \subset \mathbf{E}$  be a root system. Each nonzero  $\lambda \in \mathbf{E}$  defines in  $\mathbf{F} = \mathbf{E}^*$  a hyperplane

$$P_\lambda = \{x \in \mathbf{F}: \lambda(x) = 0\}. \quad (2)$$

The hyperplanes  $P_\alpha$  ( $\alpha \in \Delta$ ) separate  $F$  into finitely many polyhedral convex cones. The elements of  $F_{\text{reg}} = F \setminus \bigcup_{\alpha \in \Delta} P_\alpha$  are called *regular* and those of  $\bigcup_{\alpha \in \Delta} P_\alpha$  *singular*. The connected components of  $F_{\text{reg}}$  are called (*open*) *Weyl chambers*, and their closures *closed Weyl chambers*.

Since the set of singular elements is transformed into itself while multiplied by  $-1$ , then for any Weyl chamber  $C$  the set  $-C = \{x \in F: -x \in C\}$  is also a Weyl chamber, called the chamber *opposite* to  $C$ .

A subsystem  $\Pi$  of  $\Delta$  is called a *system of simple roots* (or a *base*) of  $\Delta$  if the elements of  $\Pi$  are linearly independent and any  $\beta \in \Delta$  presents in the form

$$\beta = \sum_{\alpha \in \Pi} k_\alpha \alpha, \quad (3)$$

where  $k_\alpha$  are simultaneously either nonnegative or nonpositive integers.

Clearly, the number of simple roots always equals  $\text{rk } \Delta$  and the presentation (3) is unique.

*Example 1.* For the root systems depicted in Fig. 1 the systems  $\{\alpha\}$  and  $\{\alpha_1, \alpha_2\}$  are bases.

A root  $\beta \in \Delta$  is *positive* with respect to a given base  $\Pi$  if  $k_\alpha \geq 0$  ( $\alpha \in \Pi$ ) in (3), and *negative* if  $k_\alpha \leq 0$  ( $\alpha \in \Pi$ ). If  $\Pi$  is fixed then denote the set of positive (negative) roots by  $\Delta^+$  (resp.  $\Delta^-$ ). Clearly,  $\Delta^- = -\Delta^+$ . We write  $\alpha > 0$  if  $\alpha \in \Delta^+$  and  $\alpha < 0$  if  $\alpha \in \Delta^-$ . This notation agrees with the following partial order on  $E$ :

$$\xi \geq \eta \Leftrightarrow \xi - \eta = \sum_{\alpha \in \Pi} k_\alpha \alpha, \quad k_\alpha \in \mathbb{Z}_+.$$

Now let us prove the existence of a base for any root system. We will also establish a one-to-one correspondence between the bases of  $\Delta$  and the Weyl chambers.

Let  $C$  be a Weyl chamber and  $\alpha \in \Delta$ . Since  $C$  is connected, then either  $\alpha(x) > 0$  for all  $x \in C$  or  $\alpha(x) < 0$  for all  $x \in C$  and we accordingly call  $\alpha$  a *C-positive* (*C-negative*) root. Clearly, *C-positive* roots are ( $-C$ )-negative ones and vice versa. Denote by  $\Pi(C)$  the set of all *C-positive* roots  $\alpha$  not presentable in the form  $\alpha = \beta + \gamma$ , where  $\beta$  and  $\gamma$  are *C-positive* roots.

**Theorem 1.** *For any Weyl chamber  $C$  the system  $\Pi(C)$  is a system of simple roots of  $\Delta$ . The roots positive with respect to  $\Pi(C)$  coincide with the  $C$ -positive ones and the negative roots coincide with the  $C$ -negative ones. The correspondence  $C \mapsto \Pi(C)$  is a bijection of the set of all Weyl chambers onto the set of all bases of  $\Delta$ .*

The *proof* is divided into several problems.

**Problem 12.** Each *C-positive* root  $\beta \in \Delta$  presents in the form  $\beta = \sum_{\alpha \in \Pi(C)} k_\alpha \alpha$ , where  $k_\alpha \in \mathbb{Z}_+$ .

**Problem 13.** If  $\alpha, \beta \in \Pi(C)$ ,  $\alpha \neq \beta$ , then  $\alpha - \beta \notin \Delta$  and  $(\alpha, \beta) \leq 0$ .

**Problem 14.** Let  $v_1, \dots, v_s$  be a system of nonzero vectors of a Euclidean space  $E$  with pairwise nonacute angles. If they are linearly dependent:

$$a_1 v_{i_1} + \dots + a_k v_{i_k} - b_1 v_{j_1} - \dots - b_l v_{j_l} = 0,$$

where  $i_1, \dots, i_k, j_1, \dots, j_l$  are different and all  $a_p, b_q$  are positive, then

a)  $a_1 v_{i_1} + \dots + a_k v_{i_k} = b_1 v_{j_1} + \dots + b_l v_{j_l} = 0$ ;

b)  $(v_{i_p}, v_{j_q}) = 0$  for  $p = 1, \dots, k; q = 1, \dots, l$ .

If  $v_1, \dots, v_s$  belong to an open halfspace of  $\mathbf{E}$  then they are linearly independent.

This implies the first two statements of the theorem. The injectivity of the map  $C \mapsto \Pi(C)$  follows from

**Problem 15.**  $C = \{x \in \mathbf{F}: \alpha(x) > 0 \text{ for all } \alpha \in \Pi(C)\} = \{x \in \mathbf{F}: \alpha(x) > 0 \text{ for all } C\text{-positive roots } \alpha\}$ .

Let us prove that the map  $C \mapsto \Pi(C)$  is surjective.

**Problem 16.** Let  $V$  be a finite-dimensional vector space over  $\mathbb{R}$  and  $\gamma_1, \dots, \gamma_r$  a linearly independent system of vectors of  $V^*$ . Then there exists a vector  $x \in V$ , such that  $\gamma_i(x) > 0$  ( $i = 1, \dots, r$ ).

**Problem 17.** If  $\Pi$  is a base in  $\Delta$ , then  $C = \{x \in \mathbf{F}: \alpha(x) > 0 (\alpha \in \Pi)\}$  is a Weyl chamber and  $\Pi = \Pi(C)$ .

A hyperplane  $P \subset \mathbf{F}$  is called a *wall of a Weyl chamber*  $C$  if  $P \cap C = \emptyset$  and  $P \cap \bar{C}$  contains a nonempty subset open in  $P$ .

**Problem 18.** If  $C$  is a Weyl chamber then  $\bar{C} = \{x \in \mathbf{F}: \alpha(x) \geq 0 (\alpha \in \Pi(C))\}$ . The hyperplanes  $P_\alpha$ , where  $\alpha \in \Pi(C)$ , are the walls of  $C$ .

Thus any Weyl chamber is a simplicial cone.

**Problem 19.** Any hyperplane  $P_\alpha$ , where  $\alpha \in \Delta$ , is a wall of a Weyl chamber. For any  $\alpha \in \Delta$  there exists a Weyl chamber  $C$  such that  $\alpha \in \Pi(C)$  (or perhaps  $\frac{1}{2}\alpha \in \Pi(C)$ , if  $\Delta$  is not reduced).

In the following problems a fixed base  $\Pi \subset \Delta$  is considered.

**Problem 20.** If  $\alpha \in \Delta^+ \setminus \Pi$ , then there exists  $\beta \in \Pi$  such that  $\alpha - \beta \in \Delta$  and  $\alpha - \beta > 0$ .

**Problem 21.** Any positive root  $\alpha \in \Delta$  presents in the form  $\alpha = \alpha_1 + \dots + \alpha_s$ , where  $\alpha_i \in \Pi$  and  $\alpha_1 + \dots + \alpha_k \in \Delta$  for any  $k = 1, \dots, s$ .

**Problem 22.** A root system  $\Delta$  is indecomposable if and only if so is a base  $\Pi \subset \Delta$ . If  $\Delta = \Delta_1 \cup \dots \cup \Delta_r$  is the decomposition of  $\Delta$  into irreducible components then  $\Pi = \Pi_1 \cup \dots \cup \Pi_r$ , where  $\Pi_i \subset \Delta_i$  is a base.

The latter statement has important applications in the theory of semisimple Lie algebras. A *system of simple roots of a semisimple Lie algebra*  $\mathfrak{g}$  is any base of  $\Delta_{\mathfrak{g}}$ . Problems 22 and 7 imply

**Theorem 2.** A semisimple Lie algebra  $\mathfrak{g}$  is simple if and only if its system of simple roots  $\Pi$  is indecomposable. If  $\Pi = \Pi_1 \cup \dots \cup \Pi_r$  is the decomposition into indecomposable components then  $\mathfrak{g} = \mathfrak{g}_1 \oplus \dots \oplus \mathfrak{g}_r$ , where  $\mathfrak{g}_i$  is the simple ideal, whose system of simple roots is  $\Pi_i$ .

Let us indicate another useful construction of bases which historically preceded the one described above. A real vector space  $\mathbb{E}$  over  $\mathbb{R}$  is called *ordered* if  $\mathbb{E}$  is endowed with an order  $<$  such that for any  $\lambda, \mu \in \mathbb{E}$  we have

- 1)  $\lambda > 0, \mu > 0 \Rightarrow \lambda + \mu > 0$ ;
- 2)  $\lambda > 0, c \in \mathbb{R}, c > 0 \Rightarrow c\lambda > 0$ .

Clearly,  $-\lambda < 0$  for any  $\lambda > 0$ . An example of an order satisfying 1) and 2) is the lexicographic order with respect to a basis of  $\mathbb{E}$  defined as follows:  $\lambda > \mu$  if the first nonzero coordinate of  $\lambda - \mu$  with respect to this basis is positive.

Let  $\Delta$  be a root system in an ordered Euclidean space  $\mathbb{E}$ . Let  $\Pi$  be the set of roots  $\alpha > 0$ , such that  $\alpha \neq \beta + \gamma$ , where  $\beta, \gamma \in \Delta, \beta > 0, \gamma > 0$ .

**Problem 23.**  $\Pi$  is a base of  $\Delta$  and the corresponding set  $\Delta^+$  coincides with the set of all roots which are positive with respect to the given order.

*Example 2.* Let us specify subsystems of positive and simple roots for the root systems  $\Delta_{\mathfrak{g}}$  of the classical Lie algebras  $\mathfrak{g}$  described in 1.5°.

$\mathfrak{g} = \mathfrak{gl}_n(\mathbb{C}), n \geq 2$ . Considering the lexicographic order in  $\mathfrak{t}(\mathbb{R})^*$  with respect to the basis  $\varepsilon_1, \dots, \varepsilon_n$  we get

$$\Delta_{\mathfrak{g}}^+ = \{\varepsilon_i - \varepsilon_j; i < j; i, j = 1, \dots, n\},$$

$$\Pi_{\mathfrak{g}} = \{\alpha_1, \dots, \alpha_{n-1}\}, \quad \text{where } \alpha_i = \varepsilon_i - \varepsilon_{i+1}.$$

The corresponding Weyl chamber  $C \subset \mathbb{F} = \mathfrak{t}(\mathbb{R})$  is the set of the diagonal matrices  $\text{diag}(x_1, \dots, x_n)$  such that  $x_1 > x_2 > \dots > x_n$ .

$\mathfrak{g} = \mathfrak{sl}_n(\mathbb{C}), n \geq 2$ . Problem 1.29 implies that  $\Delta_{\mathfrak{g}}^+$  and  $\Pi_{\mathfrak{g}}$  have the same form as for  $\mathfrak{gl}_n(\mathbb{C})$ .

$\mathfrak{g} = \mathfrak{so}_{2l}(\mathbb{C}), l \geq 2$ . Considering the lexicographic order in  $\mathfrak{t}_{\mathfrak{g}}(\mathbb{R})^*$  with respect to the basis  $\varepsilon_1, \dots, \varepsilon_l$  we get

$$\Delta_{\mathfrak{g}}^+ = \{\varepsilon_i \pm \varepsilon_j; i < j; i, j = 1, \dots, l\},$$

$$\Pi_{\mathfrak{g}} = \{\alpha_1, \dots, \alpha_l\}, \quad \text{where } \alpha_i = \varepsilon_i - \varepsilon_{i+1} (1 \leq i \leq l-1), \alpha_l = \varepsilon_{l-1} + \varepsilon_l.$$

$\mathfrak{g} = \mathfrak{so}_{2l+1}(\mathbb{C}), l \geq 1$ . Similarly,

$$\Delta_{\mathfrak{g}}^+ = \{\varepsilon_i \pm \varepsilon_j (i < j), \varepsilon_i; i, j = 1, \dots, l\},$$

$$\Pi_{\mathfrak{g}} = \{\alpha_1, \dots, \alpha_l\}, \quad \text{where } \alpha_i = \varepsilon_i - \varepsilon_{i+1} (1 \leq i \leq l-1), \alpha_l = \varepsilon_l.$$

$\mathfrak{g} = \mathfrak{sp}_{2l}(\mathbb{C}), l \geq 1$ . Similarly,

$$\Delta_{\mathfrak{g}}^+ = \{\varepsilon_i \pm \varepsilon_j (i < j), 2\varepsilon_i; i, j = 1, \dots, l\},$$

$$\Pi_{\mathfrak{g}} = \{\alpha_1, \dots, \alpha_l\}, \quad \text{where } \alpha_i = \varepsilon_i - \varepsilon_{i+1} (1 \leq i \leq l-1), \alpha_l = 2\varepsilon_l.$$

As it is easy to verify all the described bases  $\Pi_{\mathfrak{g}}$  are indecomposable except for  $\mathfrak{g} = \mathfrak{so}_4(\mathbb{C})$  (in 5° we will give a beautiful geometric method to verify this inde-

composability). Therefore Theorem 2 implies that all semisimple classical Lie algebras are simple except  $\mathfrak{so}_4(\mathbb{C})$ .

Let us now return to the notation from the beginning of the section and consider the dual root system  $\Delta^\vee \subset \mathbb{F}$ . The natural isomorphism  $\lambda \mapsto u_\lambda$  of Euclidean spaces  $\mathbb{E} \rightarrow \mathbb{F}$  maps each hyperplane  $L_\lambda$  onto  $P_\lambda$ . Clearly

$$L_\lambda = \{\mu \in E: \alpha^\vee(\mu) = 0\} \quad (\alpha \in \Delta). \quad (4)$$

Therefore this isomorphism maps the Weyl chambers of  $\Delta^\vee$  onto the Weyl chambers of  $\Delta$ .

**Problem 24.** Let  $\Delta$  be a reduced root system,  $\Pi$  its base. The  $\Pi^\vee = \{\alpha^\vee: \alpha \in \Pi\}$  is a base of  $\Delta^\vee$ .

**3°. Borel Subgroups and Maximal Tori.** In this section we will consider the root system  $\Delta_G$  of a reductive algebraic group  $G$  with respect to a fixed maximal torus  $T$ . We will see that Weyl chambers in  $F = \mathfrak{t}_\mathbb{R}$  are in one-to-one correspondence with the Borel subgroups of  $G$  containing  $T$  and we will establish several important properties of Borel subgroups and maximal tori.

Let  $C \rightarrow \mathbb{F}$  be a Weyl chamber. Let us construct from  $C$  a Borel subgroup of  $G$ . Let  $\Delta = \Delta^+ \cup \Delta^-$  be the decomposition of  $\Delta$  into the  $C$ -positive and  $C$ -negative roots. Problem 1.25 implies that the subspaces

$$\mathfrak{n}^+ = \bigoplus_{\alpha \in \Delta^+} \mathfrak{g}_\alpha, \quad \mathfrak{b}^+ = \mathfrak{t} \oplus \mathfrak{n}^+$$

are subalgebras of  $\mathfrak{g}$ . The subalgebras

$$\mathfrak{n}^- = \bigoplus_{\alpha \in \Delta^-} \mathfrak{g}_\alpha, \quad \mathfrak{b}^- = \mathfrak{t} \oplus \mathfrak{n}^-$$

are constructed similarly and correspond to the opposite Weyl chamber  $-C$ .

**Problem 25.** The Lie algebra  $\mathfrak{b}^+$  is solvable and  $\mathfrak{n}^+$  is its unipotent ideal.

**Problem 26.**  $\mathfrak{b}^+$  is a Borel subalgebra of  $\mathfrak{g}$  and coincides with its normalizer.

By Problem 3.3.8  $G$  contains a Borel subgroup  $B^+$  with the tangent algebra  $\mathfrak{b}^+$ . Clearly,  $B^+ \supset T$ . The group  $B^+$  will be called the *Borel subgroup corresponding to the Weyl chamber  $C$* . By Problem 3.3, the ideal  $\mathfrak{n}^+$  determines a unipotent normal algebraic subgroup  $N^+ \subset B^+$ . The connected algebraic subgroups  $N^- \subset B^-$  are similarly defined and  $B^-$  coincides with the Borel subgroup corresponding to the opposite Weyl chamber  $-C$ .

Note that for  $G = \mathrm{GL}_n(\mathbb{C})$  and the Weyl chamber  $C$  chosen as in the Example 2 of 3° the subgroups  $B^+$  and  $B^-$  coincide with the subgroups of all upper and lower nil-triangular matrices respectively and  $N^+$  and  $N^-$  coincide with the subgroups of the uni-triangular matrices.

**Problem 27.**  $N^+$  coincides with the unipotent radical of  $B^+$  and  $B^+ = N^+ \rtimes T$ .

**Problem 28.** Different Borel subgroups of  $G$  correspond to different Weyl chambers.

Now we wish to show that any Borel subgroup containing  $T$  corresponds to a Weyl chamber. To do so consider the normalizer  $N(T)$  of  $T$ . By Problem 1.24, to any element  $n \in N(T)$  there correspond linear transformations  $w = \text{Ad } n$  and  ${}^t w$  of  $\mathbb{F} = \mathfrak{t}(\mathbb{R})$  and  $\mathbb{E} = \mathfrak{t}(\mathbb{R})^*$  respectively, satisfying  ${}^t w(\Delta) = \Delta$ . Clearly,  $w(\mathbb{F}_r) = \mathbb{F}_r$  and  $w$  permutes the Weyl chambers. It is not difficult to see that if  $B$  is the Borel subgroup corresponding to a fixed Weyl chamber  $C$  then  $nB^+n^{-1}$  corresponds to the Weyl chamber  $w(C)$ .

**Problem 29.** Let  $B$  be any Borel subgroup of  $G$  containing  $T$ . Then there exists  $a \in N(T)$ , such that  $aBa^{-1} = B^+$ .

Problems 28, 29 and the above remarks imply

**Theorem 3.** The map  $C \mapsto B^+$  constructed above is a bijection of the set of all Weyl chambers in  $\mathbb{F}$  onto the set of all Borel subgroups of  $G$  containing  $T$ .

Now suppose that  $G$  is connected. Let us consider, as in the proof of Theorem 3.2.12, a closed orbit  $D$  of  $G$  in the flag variety. There exists  $p \in D$  whose stabilizer  $G_p$  contains  $B^+$  as the identity component. Our next aim is to prove that  $D$  is simply connected and  $G_p = B^+$ .

For this consider the orbit  $N^-(p)$  of the subgroup  $N^- \subset G$  in  $D$  which by Theorem 2.1.7 is a nonsingular algebraic subvariety. The  $G$ -action on  $D$  gives rise to the surjective morphism  $\alpha_p: G \rightarrow D$  given by the formula  $\alpha_p(g) = gp$ .

**Problem 30.** The orbit  $N^-(p)$  is open in  $D$  and  $\alpha_p: N^- \rightarrow N^-(p)$  is an isomorphism of algebraic varieties.

Since  $G$  is connected,  $D$  is irreducible. Problem 30 implies that  $D \setminus N^-(p)$  is an algebraic subvariety of a real codimension  $\geq 2$  in  $D$ . Theorem 3.3.7 implies that  $N^-(p)$  is isomorphic to  $\mathbb{C}^q$  and, in particular, it is simply connected. Therefore, so is  $D$ . This implies that  $G_p = B^+$  (see Theorem 1.3.4).

Since all Borel subgroups of  $G$  are conjugate (Theorem 3.2.12), all the results obtained for  $B$  hold for any Borel subgroup. Since any Borel subgroup of an algebraic group contains the radical of this group, the following statement holds:

**Theorem 4.** Let  $G$  be a connected algebraic group and  $B$  its Borel subgroup. Then  $D = G/B$  is a simply connected projective algebraic variety.

**Problem 31.** Prove the following theorem:

**Theorem 5.** A Borel subgroup  $B$  of a connected algebraic group  $G$  coincides with its normalizer  $N(B)$ .

From this we derive the following property of a maximal torus.

**Theorem 6.** A maximal torus of a connected reductive algebraic group  $G$  coincides with its centralizer; in particular, it contains the center of  $G$ .

**Corollary.** The intersection of all maximal tori of a connected reductive algebraic group coincides with the center of the group.

**Problem 32.** Under the conditions of Theorem 6 let  $T$  be a maximal torus contained in a Borel subgroup  $B$ . Then the normalizer  $N_B(T)$  of  $T$  in  $B$  coincides with  $T$ .

**Problem 33.** Prove Theorem 6.

**4°. Weyl Group.** We will use the notation of 2°. Let  $\lambda \in \mathbf{E}$ ,  $\lambda \neq 0$ . Recall that we denote by  $r_\lambda$  the orthogonal reflection in  $\mathbf{E}$  with respect to the hyperplane  $L_\lambda$ . Clearly, the orthogonal reflection in the dual space  $\mathbf{F} = \mathbf{E}^*$  with respect to the hyperplane given by (2) coincides with  $r_\lambda$ , but for simplicity we denote it by  $r_\lambda$  as well. Consider the groups  $W$  and  $W^\vee$  of orthogonal transformations of the spaces  $\mathbf{F}$  and  $\mathbf{E}$ , respectively, generated by reflections  $r_\alpha$  ( $\alpha \in \Delta$ ). The group  $W$  is called the *Weyl group* of the root system  $\Delta$ . It is clear from (4) that  $W^\vee$  is the Weyl group of the dual root system  $\Delta^\vee$ . Since  $r_\alpha^2 = e$ , the map  $w \rightarrow {}^t w^{-1}$  is an isomorphism  $W \rightarrow W^\vee$ .

The definition of a root system implies that  $W^\vee(\Delta) = \Delta$ . Therefore  $W$  transforms the system of singular hyperplanes  $P_\alpha$ ,  $\alpha \in \Delta$ , into itself and permutes Weyl chambers.

**Problem 34.** The Weyl group is finite.

**Theorem 7.** *The Weyl group  $W$  acts simply transitively on the set of all the Weyl chambers in  $\mathbf{F}$  and so does  $W^\vee$  on the set of all the bases of  $\Delta$ . Fix a base  $\Pi \subset \Delta$ . Then  $W$  and  $W^\vee$  are generated by reflections  $r_\alpha$ ,  $\alpha \in \Pi$ , and for any  $\alpha \in \Delta$  there exists  $w \in W^\vee$  such that  $w(\alpha) \in \Pi$  (or  $\frac{1}{2}w(\alpha) \in \Pi$ ).*

The proof uses the following notion. Two Weyl chambers  $C$  and  $C'$  are called *adjacent* if there exists a hyperplane  $P \subset \mathbf{F}$  such that  $P \cap C = P \cap C' = \emptyset$  and  $P \cap \bar{C} \cap \bar{C}'$  contains a nonempty subset, open in  $P$ . In this case the hyperplane  $P$  is a common wall of the chambers  $C$  and  $C'$  and these chambers are located on different sides of  $P$ . Problem 18 implies that the reflection with respect to  $P$  maps  $C$  and  $C'$  onto each other.

**Problem 35.** Given two Weyl chambers  $C, C'$ , there exists a sequence  $C_0, C_1, \dots, C_r$  of Weyl chambers such that  $C = C_0$ ,  $C' = C_r$  and  $C_i, C_{i+1}$  are adjacent ( $i = 0, \dots, r-1$ ).

Now fix a system of simple roots  $\Pi \subset \Delta$  and denote by  $W'$  the subgroup of  $W$  generated by the reflections  $r_\alpha$  ( $\alpha \in \Pi$ ), i.e. the reflections with respect to the walls of the Weyl chamber  $C_0$  corresponding to  $\Pi$  (Problem 18).

**Problem 36.**  $W'$  is transitive on the set of all Weyl chambers.

**Problem 37.**  $W'$  coincides with  $W$ .

**Problem 38.** Let  $w = r_{\alpha_1} \dots r_{\alpha_t}$  be an expression of an element  $w \in W$  as a product of the smallest possible number of generators  $r_\alpha$  ( $\alpha \in \Pi$ ) ( $t = 0$  if  $w = e$ ). Then the only hyperplanes of the form  $P_\beta$  ( $\beta \in \Delta$ ) that separate the Weyl chambers

$C_0$  and  $w(C_0)$  are the following  $t$  hyperplanes:

$$P_{\alpha_1}, r_{\alpha_1}(P_{\alpha_2}), \dots, r_{\alpha_1} \dots r_{\alpha_{i-1}}(P_{\alpha_i}).$$

The number  $t = l(w)$  is called the *length* of  $w$ .

Problems 36, 37, 38 and 19 imply Theorem 7.

**Theorem 8.** Any closed Weyl chamber  $\bar{C}$  is a fundamental set for the Weyl group  $W$ , i.e. it intersects the orbit  $W(y)$  of any point  $y \in F$  at a single point.

The existence of a point  $y_0 \in W(y) \cap \bar{C}$  follows from Theorem 7 and its uniqueness follows from Problem 39:

**Problem 39.** If  $y \in \bar{C} \cap w(\bar{C})$ , where  $w \in W$ , then  $w(y) = y$ .

Another application of Theorem 7 is the following important theorem which shows that a reduced root system is determined up to an isomorphism by its system of simple roots.

**Theorem 9.** Let  $\Delta \subset \mathbf{E}$ ,  $\Delta' \subset \mathbf{E}'$  be root systems of the same rank,  $\Pi \subset \Delta$  a base,  $\varphi: \langle \Delta \rangle \rightarrow \langle \Delta' \rangle$  an isomorphism of  $\Pi$  onto a subsystem  $\Pi' = \varphi(\Pi) \subset \Delta'$ . If  $\Delta$  is reduced then  $\varphi$  is an isomorphism of  $\Delta$  onto the root system  $\varphi(\Delta) \subset \Delta'$ . If  $\Delta'$  is also reduced and  $\Pi'$  is a base of  $\Delta'$  then  $\varphi(\Delta) = \Delta'$ .

**Problem 40.** Prove this theorem.

Now consider the case when  $\Delta = \Delta_G$  is the root system of a reductive algebraic group  $G$  with respect to a maximal torus  $T$ . Consider the map  $v: n \mapsto (\text{Ad } n)|_{\mathfrak{t}(\mathbb{R})}$  of  $N(T)$  in the group of orthogonal transformations of the space  $\mathbf{F} = \mathfrak{t}(\mathbb{R})$ . Clearly, this map is a homomorphism. Let  $W''$  be its image. It is clear from Problem 1.37 that  $W \subset W''$ .

**Problem 41.** The kernel of the homomorphism  $v: N(T) \rightarrow W''$  coincides with  $T$ .

**Problem 42.** The group  $W''$  acts simply transitively on the set of Weyl chambers and coincides with  $W$ .

Therefore, we have proved

**Theorem 10.** The homomorphism  $v$  defines an isomorphism of the group  $N(T)/T$  onto the Weyl group of the root system  $\Delta_G$ .

Problem 42 gives also another proof of simple transitivity of the Weyl group action on the set of Weyl chambers (cf. Theorem 7).

The Weyl group of the root system  $\Delta_G$  is called the *Weyl group of the reductive algebraic group  $G$  or of its Lie algebra  $\mathfrak{g}$* .

*Example.* Let  $G = \text{GL}_n(\mathbb{C})$  and let  $T$  be the subgroup of all invertible diagonal matrices (see 1.5°). In  $\mathfrak{t}(\mathbb{R})$ , consider the basis  $\{E_{ii} (i = 1, \dots, n)\}$ . Clearly, the reflection  $r_{\alpha_{ij}}$  transposes  $E_{ii}$  with  $E_{jj}$  and preserves all other vectors of the basis. Therefore,  $W \cong S_n$ . The group  $N(T)$  is the group of all monomial matrices, i.e. matrices with exactly one nonzero element in each row and column.

**5°. Dynkin Diagrams.** Let  $\Gamma = \{\gamma_1, \dots, \gamma_s\}$  be a system of nonzero vectors in a Euclidean space  $\mathbf{E}$ . A graph may be assigned to  $\Gamma$  which clarifies how this system decomposes into indecomposable components in the sense of 1°. Namely, to each vector  $\gamma_i$  assign a vertex of the graph and join the vertices corresponding to the vectors  $\gamma_i$  and  $\gamma_j$  if and only if  $(\gamma_i, \gamma_j) \neq 0$ . Clearly, the indecomposable components of  $\Gamma$  correspond exactly to the connected components of this graph. The edges of the graph may be endowed with additional labels which help us to recover the data on the angles between the vectors  $\gamma_i$  and the ratios of their lengths. We will only do this for one special class of vector systems.

A system of nonzero vectors  $\Gamma = \{\gamma_1, \dots, \gamma_s\}$  of a Euclidean space  $\mathbf{E}$  is *admissible* if  $a_{ij} = \langle \gamma_i | \gamma_j \rangle$  is a nonpositive integer for any  $i \neq j$ . The integer matrix  $A(\Gamma) = (a_{ij})$ , where  $a_{ij} = \langle \gamma_i | \gamma_j \rangle$ , is called the *matrix of  $\Gamma$* .

The condition  $a_{ij} \leq 0$  means that the angle  $\theta_{ij}$  between  $\gamma_i$  and  $\gamma_j$  is not acute. Indeed, the numbers  $a_{ij}$ ,  $m_{ij} = a_{ij}a_{ji}$  and  $\theta_{ij}$  for an admissible system can only take the values indicated in Problem 8. In particular,  $m_{ij} = 0, 1, 2, 3$  or  $4$  and  $\theta_{ij} = \pi(1 - 1/n_{ij})$ , where  $n_{ij} = 2, 3, 4, 6$  or  $\infty$ , respectively.

The *Dynkin diagram* of an admissible system is constructed as follows:

- 1) a vertex of the diagram corresponds to each vector  $\gamma_i$ ;
- 2) the  $i$ -th vertex is joined with the  $j$ -th ( $i \neq j$ ) by an edge of multiplicity  $m_{ij}$  (in particular, for  $m_{ij} = 0$  the vertices are separated);
- 3) if  $|a_{ij}| < |a_{ji}|$  then the corresponding edge is oriented by an arrow with the  $j$ -th vertex as the source and the  $i$ -th as the target.

A *principal submatrix* of a matrix is one located at the intersection of rows and columns indexed by the same numbers. The principal submatrices of the matrix  $A(\Gamma)$  correspond to the subsystems of  $\Gamma$  and the subdiagrams of its Dynkin diagram.

Clearly,  $A(\Gamma)$  is obtained from the Gram matrix of  $\Gamma$  by multiplying the columns of the latter by  $2/(\gamma_i, \gamma_i) > 0$ . Therefore  $\det A(\Gamma) \geq 0$  and  $\det A(\Gamma) > 0$  if and only if  $\Gamma$  is linearly independent.

**Problem 43.** The Dynkin diagram of an admissible system of vectors determines this system up to an isomorphism (in the sense of 1°).

**Problem 44.** If  $\Gamma = \{\gamma_1, \dots, \gamma_s\}$  is an admissible system of vectors then so is  $\Gamma^\vee = \{\gamma_1^\vee, \dots, \gamma_s^\vee\}$ , where  $\gamma_i^\vee = 2u_{\gamma_i}/(\gamma_i, \gamma_i)$ ,  $u_{\alpha_i}$  is the vector of  $\mathbf{E}^*$  corresponding to  $\gamma_i$  under the natural isomorphism. The Dynkin diagram of  $\Gamma^\vee$  is obtained from the Dynkin diagram of  $\Gamma$  by reversing the orientation of all oriented edges.

An example of an admissible system of vectors is the base of any root system  $\Delta$  (see Problem 13). By Theorem 7 the Dynkin diagram of  $\Pi$  does not depend on the choice of the base of  $\Delta$ ; therefore this diagram might be called the *Dynkin diagram of  $\Delta$* . Theorem 9 implies that the Dynkin diagram of a reduced root system determines this system uniquely up to an isomorphism. We will denote this diagram in the same way as the reduced root system to which it corresponds. Problems 24 and 42 imply that the passage to the dual root system reverses the orientation of all (oriented) edges of the Dynkin diagram.

If  $\Delta = \Delta_G = \Delta_{\mathfrak{g}}$  is a root system of a reductive algebraic group  $G$  or its tangent algebra  $\mathfrak{g}$  then the Dynkin diagram of  $\Delta$  is also called the *Dynkin diagram of  $G$*  or  $\mathfrak{g}$ . In §3 we will prove that a semisimple Lie algebra is determined uniquely up to an isomorphism by its Dynkin diagram. Note also that a semisimple Lie algebra is simple if and only if its Dynkin diagram is connected and the connected components of a general Dynkin diagram are in one-to-one correspondence with the simple ideals of the corresponding semisimple Lie algebra (see Theorem 2).

*Example 1)* The Dynkin diagrams of the root systems described in Fig. 1 are of the form

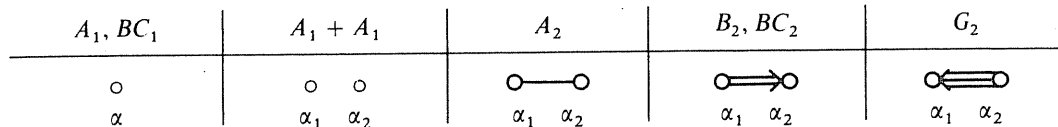

*Example 2)* The Dynkin diagrams of the classical simple Lie algebras (see Example 2 of 2°) are of the following form (here  $l$  is the rank of the Lie algebra, equal to the number of vertices of the diagram; in the right column the standard notation of the Dynkin diagram is indicated):

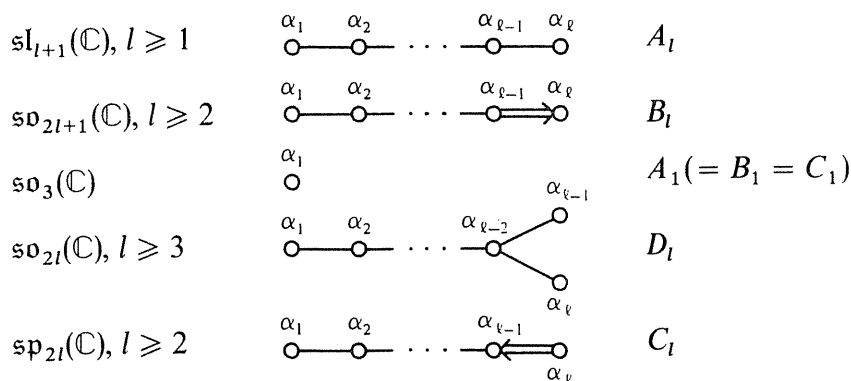

All of the above admissible systems of vectors are linearly independent. Now we will give examples of linearly dependent admissible systems.

**Problem 45.** Let  $\Gamma = \{\gamma_1, \dots, \gamma_s\}$  be an indecomposable linearly dependent system of nonzero vectors of a Euclidean space with pairwise nonacute angles. Then all proper subsystems of  $\Gamma$  are linearly independent. In particular, the rank of  $\Gamma$  is  $s - 1$ . Any linear relation among  $\gamma_1, \dots, \gamma_s$  is proportional to one fixed relation of the form  $\sum_{1 \leq i \leq s} c_i \gamma_i = 0$ , where  $c_i > 0$  for all  $i$ .

Let  $\Delta$  be a root system. In  $\Delta$ , choose a base  $\Pi$  and consider the corresponding partial order (see 2°). Clearly, in  $\Pi$  there are elements maximal with respect to this order, i.e. roots  $\delta \in \Delta$  such that  $\gamma \in \Delta, \gamma \geq \delta$  implies  $\gamma = \delta$ .

**Problem 46.** For any maximal root  $\delta \in \Delta$  we have  $(\delta, \alpha) \geq 0$  for all  $\alpha \in \Pi$  and  $(\delta, \beta) > 0$  for some  $\beta \in \Pi$ .

**Problem 47.** An indecomposable root system  $\Delta$  contains a unique maximal with respect to  $\Pi$  root  $\delta$  and  $\delta = \sum_{\alpha \in \Pi} n_\alpha \alpha$ , where  $n_\alpha$  are positive integers.

Let  $\Delta$  be an indecomposable root system. Problem 47 implies that the unique maximal root  $\delta \in \Delta$  is the largest element of this system. The root  $\delta$  is called the *highest root* and  $\alpha_0 = -\delta$  the *lowest root* of  $\Delta$ . If  $\Pi = \{\alpha_1, \dots, \alpha_l\}$ , then  $\tilde{\Pi} = \{\alpha_0, \alpha_1, \dots, \alpha_l\}$  is called the *extended system of simple roots (extended base)* of  $\Delta$ . Problem 46 implies that  $\tilde{\Pi}$  is an indecomposable linearly dependent admissible root system. The Dynkin diagram of  $\tilde{\Pi}$  is called the *extended Dynkin diagram* of  $\Delta$ .

When  $\Delta$  is a root system of a simple noncommutative algebraic group  $G$  (or Lie algebra  $\mathfrak{g}$ ) one speaks about the *extended system of simple roots and the extended Dynkin diagram of  $G$  (or  $\mathfrak{g}$ )*.

*Example 3.* Extended Dynkin diagrams of simple classical Lie algebras are of the following form (each diagram contains  $l + 1$  vertices; in the right column the standard notation for each diagram is given):

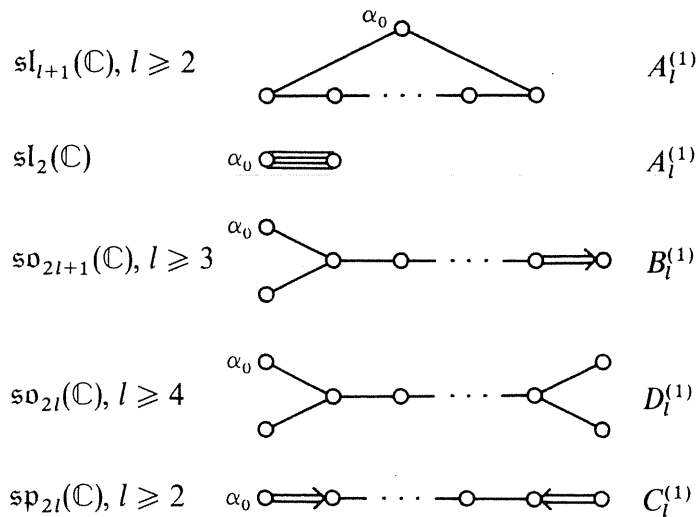

The extended Dynkin diagram for  $G_2$  is of the form



*Example 4.* Reversing orientation of multiple edges in the diagrams  $B_l^{(1)}, C_l^{(1)}, G_2^{(1)}$  (i.e. passing to the dual root system, Problem 44) we get the following connected Dynkin diagrams (the first two have  $l + 1$  vertices):

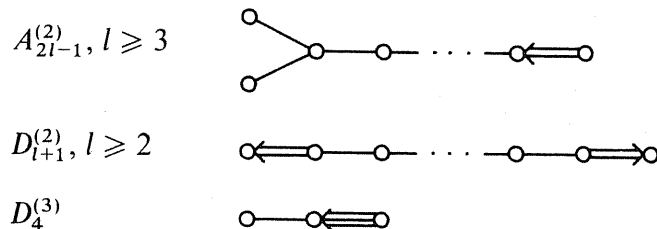

It is easy to verify that these diagrams also correspond to admissible systems of vectors obtained from the bases  $\Pi$  of root systems  $\Delta$  of types  $C_l$ ,  $B_l$ ,  $G_2$  by adjoining the roots  $-(\varepsilon_1 + \varepsilon_2)$ ,  $-\varepsilon_1$ ,  $-(2\alpha_1 + \alpha_2)$  respectively (in notation of Examples 2 and 1 of 2°). The adjoined root is the smallest of the roots of the minimal length in  $\Delta$ . The left-end vertex of the Dynkin diagram corresponds to it (for  $A_{2l-1}^{(2)}$  any of the two left-end vertices).

*Example 5.* Adjoining the vector  $-2\varepsilon_1$  to the base of the root system of type  $B_l$  we also get a linearly dependent admissible system of vectors. Its Dynkin diagram is of the form

$$A_{2l}^{(2)}, l \geq 2 \quad \circ \rightleftarrows \circ - \dots - \circ - \circ \rightleftarrows \circ$$

and the adjoined vector corresponds to the left-end vertex of the diagram.

**6°. Cartan Matrices.** Here we will find out which matrices might serve as matrices of admissible systems of vectors. Clearly, the matrix  $A(\Gamma) = (a_{ij})$  of an admissible system of vectors  $\Gamma = \{\gamma_1, \dots, \gamma_s\}$  has the following properties:

- 1)  $a_{ii} = 2$  ( $i = 1, \dots, s$ );
- 2) if  $i \neq j$  then  $a_{ij} \leq 0$  and if  $a_{ij} = 0$  then  $a_{ji} = 0$ ;
- 3)  $a_{ij} \in \mathbb{Z}$  and  $m_{ij} = a_{ij}a_{ji} = 0, 1, 2, 3$  or  $4$ .

Together with  $A(\Gamma)$  we will also consider the matrix  $G(\Gamma) = (g_{ij})$ , where  $g_{ij} = \cos \theta_{ij}$  and  $\theta_{ij}$  is the angle between  $\gamma_i$  and  $\gamma_j$ . This is the Gram matrix of the normalized system of vectors  $\gamma_1/|\gamma_1|, \dots, \gamma_s/|\gamma_s|$ .

**Problem 48.** The elements of  $G(\Gamma)$  are of the form

$$g_{ii} = 1 \quad (i = 1, \dots, s), \quad g_{ij} = -\frac{1}{2}\sqrt{m_{ij}} \quad (i \neq j). \quad (5)$$

Therefore we have one more property of  $A(\Gamma)$ :

4) a symmetric matrix  $(g_{ij})$  whose elements are defined by formulas (5) is positive semi-definite, i.e. determines a positive semi-definite quadratic form.

A square matrix  $A = (a_{ij})$  is *admissible* if it satisfies 1)–4). An admissible matrix is called a *Cartan matrix* if the corresponding matrix  $(g_{ij}) = G(A)$  is positive definite (which is equivalent to its invertibility) and an *affine Cartan matrix* if  $G(A)$  is singular.

The above makes it clear that the matrix  $A(\Gamma)$  of a linearly independent admissible system of vectors  $\Gamma$  is a Cartan matrix and the matrix of a linearly dependent admissible system of vectors is an affine Cartan matrix. In particular, the Cartan matrix  $A(\Pi)$ , where  $\Pi$  is a base of  $\Delta$ , corresponds to any root system  $\Delta$ , and if  $\Delta$  is indecomposable the affine Cartan matrix  $A(\tilde{\Gamma})$  corresponds to it.

Notice that to any admissible matrix  $A = (a_{ij})$  we may assign the Dynkin diagram which uniquely determines the matrix up to the same permutation of rows and columns. In this correspondence the vertices of the diagram correspond to the columns of  $A$  and the edges are constructed by the rules 2), 3) given in 5°.

Clearly, if  $A$  is an admissible matrix then so is  $A^T$  and  $G(A) = G(A^T)$  while the Dynkin diagram for  $A^T$  is obtained from the Dynkin diagram for  $A$  by reversion of the orientation of the edges. If  $A = A(\Gamma)$ , where  $\Gamma$  is an admissible root system, then  $A^T = A(\Gamma^\vee)$  (see Problem 44). A principal submatrix of an admissible matrix  $A$  is obviously admissible; a subdiagram of the Dynkin diagram of  $A$  corresponds to it.

We say that the matrix  $A$  is *decomposable into the direct sum* of  $A_1$  and  $A_2$  if there exists a permutation of rows and the same permutation of columns that reduces  $A$  to the form  $\begin{pmatrix} A_1 & 0 \\ 0 & A_2 \end{pmatrix}$ ; and  $A$  is *indecomposable* otherwise. Clearly, any matrix uniquely presents as the direct sum of indecomposable matrices (we assume that the matrices are considered up to the same permutation of rows and columns). A splitting of the Dynkin diagram into the union of its connected components corresponds to this decomposition, if the matrix is admissible.

Now we will prove that any admissible matrix is a matrix of an admissible system of vectors.

**Problem 49.** Any positive semi-definite symmetric matrix  $G$  of order  $l$  is the Gram matrix of a system of  $l$  vectors of a Euclidean space. The rank of this system of vectors equals  $\text{rk } G$ .

**Problem 50.** Let the Dynkin diagram of an admissible matrix  $A$  do not contain cycles and let  $u_1, \dots, u_l$  be a system of vectors of a Euclidean space  $E$  whose Gram matrix is  $G(A)$ . Then there exist  $p_i > 0$  ( $i = 1, \dots, l$ ) such that  $A$  is the matrix of the system  $\gamma_1 = p_1 u_1, \dots, \gamma_l = p_l u_l$  and  $(\gamma_i, \gamma_j) \in \mathbb{Q}$  for all  $i, j$ .

Before we consider the case when the Dynkin diagram contains a cycle, let us make the following remark. If  $B$  is a principal submatrix of  $A$ , then  $G(B)$  is a principal submatrix of  $G(A)$ . Therefore if  $A$  is a Cartan matrix then so is  $B$ . Furthermore, if  $A$  is an indecomposable affine Cartan matrix then applying Problem 45 to the system of vectors whose Gram matrix is  $G(A)$  we see that any proper principal submatrix of  $A$  is a Cartan matrix.

**Problem 51.** If the Dynkin diagram of an indecomposable admissible matrix  $A$  contains a cycle then  $A = A(\tilde{\Gamma})$ , where  $\tilde{\Gamma}$  is the extended system of simple roots of  $\mathfrak{sl}_{l+1}(\mathbb{C})$ ,  $l \geq 2$ , and the Dynkin diagram is of the type  $A_l^{(1)}$  (see Example 3 of 5°).

Problem 50 and 51 immediately imply

**Theorem 11.** Any admissible matrix  $A$  is the matrix of an admissible system of vectors  $\Gamma = \{\gamma_1, \dots, \gamma_l\}$  of a Euclidean space such that  $(\gamma_i, \gamma_j) \in \mathbb{Q}$  for all  $i, j$ .

**Corollary.** If  $A$  is an admissible matrix of order  $l$  then  $\det A \geq 0$  and  $A$  is a Cartan matrix if and only if  $\det A > 0$ .

Notice also the following fact.

**Problem 52.** If the Dynkin diagram of an indecomposable admissible matrix  $A$  contains an edge of multiplicity 4 then  $A$  is an affine  $2 \times 2$  Cartan matrix.

**7°. Classification.** In this section we will classify (up to an isomorphism) all admissible systems of vectors. With Theorem 9 this implies the classification of root systems.

As follows from Theorem 11 the classification of admissible systems of vectors is equivalent to the classification of admissible matrices or of Dynkin diagrams corresponding to these matrices. It suffices to list all the indecomposable admissible systems, i.e. connected Dynkin diagrams. For brevity we will call the Dynkin diagram of a Cartan matrix a *Dynkin diagram* and the Dynkin diagram of an affine Cartan matrix an *affine Dynkin diagram*. The *rank* of a diagram is the rank of the corresponding admissible system of vectors (or the admissible matrix). For a Dynkin diagram the rank equals the number of its vertices and for a connected affine Dynkin diagram it equals the number of its vertices minus 1 (see Problem 44).

Each connected Dynkin diagram is denoted by a symbol of the form  $L_l$ , where  $L$  is a Latin capital and  $l$  is the rank of the diagram. This notation will be introduced during the classification. We already know the following connected Dynkin diagrams:  $A_l$  ( $l \geq 1$ ),  $B_l$  ( $l \geq 1$ ),  $C_l$  ( $l \geq 1$ ),  $D_l$  ( $l \geq 3$ ),  $G_2$  (see 5°, Examples 1, 2). The Dynkin diagrams of the first four series are called *classical*; they correspond to the classical complex Lie groups  $SL_{l+1}(\mathbb{C})$ ,  $SO_{2l+1}(\mathbb{C})$ ,  $Sp_{2l}(\mathbb{C})$ ,  $SO_{2l}(\mathbb{C})$  respectively.

$G_2$  is the first example of a nonclassical Dynkin diagram. Note that  $A_1 = B_1 = C_1$ ,  $B_2 = C_2$ ,  $A_3 = D_3$ .

Each of the listed above Dynkin diagrams  $L_l$  can be extended to a connected affine Dynkin diagram  $L_l^{(1)}$  of rank  $l$  by adjoining one vertex (see 5°, Example 3). Other connected affine Dynkin diagrams are listed in Examples 4, 5 of 5°. Notice that the connected affine Dynkin diagrams are denoted by the symbols  $L_l^{(k)}$ , where  $k = 1, 2, 3$  and  $l$  coincides with the rank of the system if  $k = 1$  but does not coincide with the rank for  $k > 1$ . The meaning of this notation will be explained in §4.

Notice the following properties of Dynkin diagrams which are consequences of Problems 51, 52 and Remarks in 6°:

- (D1) Any subdiagram of a Dynkin diagram is a Dynkin diagram.
- (D2) A diagram obtained from a Dynkin diagram (or an affine Dynkin diagram) by reversing orientation of all its edges is a Dynkin diagram (affine Dynkin diagram).
- (D3) The multiplicity of an edge of a Dynkin diagram equals 1, 2 or 3.
- (D4) A Dynkin diagram does not contain cycles.
- (D5) An affine Dynkin diagram is not a Dynkin diagram and vice versa.
- (D6) Any proper subdiagram of a connected affine Dynkin diagram is a Dynkin diagram.
- (D7) The multiplicity of an edge of a connected affine Dynkin diagram of rank  $> 1$  equals 1, 2 or 3.
- (D8) The diagrams  $A_l^{(1)}$  ( $l \geq 2$ ) are the only affine Dynkin diagrams with cycles.

**Problem 53.** The only Dynkin diagrams of rank 1 and 2 are  $A_1, A_2, B_2, G_2$ .



**Problem 55.** A connected Dynkin diagram may possess no more than one singularity. The only connected affine Dynkin diagrams with at least two singularities are the diagrams  $B_l^{(1)}$  ( $l \geq 3$ ),  $C_l^{(1)}$  ( $l \geq 2$ ),  $D_l^{(1)}$  ( $l \geq 5$ ),  $D_{l+1}^{(2)}$  ( $l \geq 2$ ),  $A_{2l}^{(2)}$  ( $l \geq 2$ ),  $A_{2l-1}^{(2)}$  ( $l \geq 3$ ).

It easily follows from (D4) that the connected Dynkin diagrams without singularities are the diagrams  $A_l$ ,  $l \geq 1$ . Similarly, properties (D8) and (D5) imply that the connected affine Dynkin diagrams without singularities are the diagrams  $A_l^{(1)}$ ,  $l \geq 2$ . By Problem 55 it only remains to list the diagrams containing exactly one singularity. We may assume that the rank of the diagram is  $\geq 3$  and the singularity is either a simple branch vertex or an edge of multiplicity 2 (see Corollary of Proposition 1).

A connected Dynkin diagram of rank  $\geq 3$  with a singularity different from  $B_l$ ,  $C_l$ ,  $D_l$  should contain a subdiagram of the form

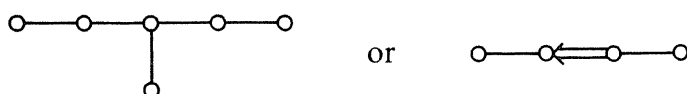

The same applies to any connected affine Dynkin diagram of rank  $\geq 3$  with exactly one singularity which is either a simple branch vertex or a double edge. Consider the following diagrams with  $l$  vertices which for the indicated values of  $l$  are not classical Dynkin diagrams:

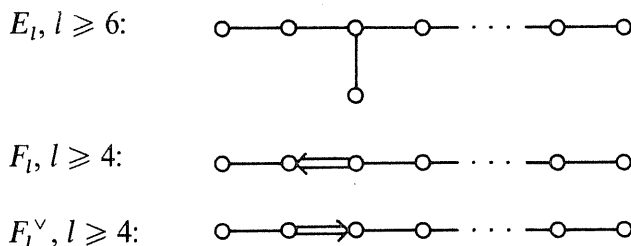

Denote by  $\delta(L)$  the determinant of the admissible matrix with Dynkin diagram  $L$ .

**Problem 56.**  $\delta(E_l) = l - 1$ ,  $\delta(F_l) = \delta(F_l^v) = 5 - l$ . The diagram  $E_l$  is a Dynkin diagram for  $l = 6, 7, 8$ ,  $F_l$  and  $F_l^v$  are Dynkin diagrams for  $l = 4$  and  $F_4 = F_4^v$ . The diagrams  $E_9 = E_8^{(1)}$ ,  $F_5 = F_4^{(1)}$ ,  $F_5^v = E_6^{(2)}$ , are connected affine Dynkin diagrams.

**Problem 57.** The diagrams  $E_6$  and  $E_7$  are subdiagrams of the following connected affine Dynkin diagrams

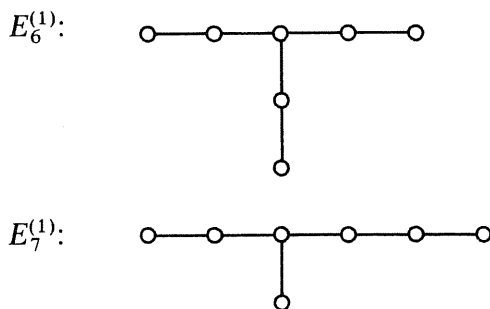

**Problem 58.** Any nonclassical connected Dynkin diagram of rank  $\geq 3$  is one of the diagrams  $E_6, E_7, E_8, F_4$ . Any connected affine Dynkin diagram with one singularity which is a simple branch vertex or a double edge is one of the diagrams  $E_6^{(1)}, E_7^{(1)}, E_8^{(1)}, F_4^{(1)}, E_6^{(2)}$ .

Let us summarize the obtained results.

**Theorem 12.** *The connected Dynkin diagrams are exhausted by the diagrams  $A_l$  ( $l \geq 1$ ),  $B_l$  ( $l \geq 1$ ),  $C_l$  ( $l \geq 1$ ),  $D_l$  ( $l \geq 3$ ),  $E_l$  ( $l = 6, 7, 8$ ),  $F_4$ ,  $G_2$  (see Table 1). The connected affine Dynkin diagrams are exhausted by the diagrams  $L_l^{(1)}$  where  $L_l$  is a connected Dynkin diagram of rank  $l$  and the diagrams  $A_{2l-1}^{(2)}$  ( $l \geq 3$ ),  $A_{2l}^{(2)}$  ( $l \geq 1$ ),  $D_{l+1}^{(2)}$  ( $l \geq 2$ ),  $E_6^{(2)}$ ,  $D_4^{(3)}$  (see Table 6).*

The Dynkin diagrams  $E_6, E_7, E_8, F_4$  and  $G_2$  are called *exceptional*. We have not decided yet if the first 4 of them are the Dynkin diagrams of some reduced root systems. One can show that this is actually so e.g. by explicitly constructing the corresponding root systems (in § 3 we give another proof making use of Lie algebras).

**Problem 59.** The systems of vectors of the types  $E_6, E_7, E_8, F_4$  given in Table 1 are the reduced root systems with the Dynkin diagrams  $E_6, E_7, E_8, F_4$ , respectively. Their extended Dynkin diagrams coincide with the diagrams  $E_6^{(1)}, E_7^{(1)}, E_8^{(1)}, F_4^{(1)}$ .

As a result of the classification of reduced root systems we get the following theorem.

**Theorem 13.** *The indecomposable reduced root systems are exhausted up to an isomorphism by the systems of the types  $A_l$  ( $l \geq 1$ ),  $B_l$  ( $l \geq 2$ ),  $C_l$  ( $l \geq 3$ ),  $D_l$  ( $l \geq 4$ ),  $E_6, E_7, E_8, F_4, G_2$  of Table 1.*

Now list the nonreduced indecomposable root systems.

**Problem 60.** If  $\Delta$  is an arbitrary root system then  $\Delta_0 = \{\alpha \in \Delta: \frac{1}{2}\alpha \notin \Delta\}$  is a reduced root system, indecomposable if and only if so is  $\Delta$ . The root systems  $\Delta$  and  $\Delta_0$  have the same Weyl chambers, the same bases and the same Weyl groups.

**Problem 61.** If  $\Delta$  is a nonreduced indecomposable root system then  $\Delta_0$  is of type  $B_l$ .

**Problem 62.** Prove the following theorem:

**Theorem 14.** *The only indecomposable nonreduced root system of rank  $l$  is the root system of type  $BC_l$  ( $l \geq 1$ ), the union of the systems  $B_l$  and  $C_l$  (see Table 1).*

**8°. Root and Weight Lattices.** Let  $V$  be a finite-dimensional vector space over  $\mathbb{R}$ . As we know (see Problem 1.2.30), any discrete subgroup of the vector group  $V$  is a free abelian subgroup whose basis is a linearly independent system of vectors. Such subgroups of  $V$  will be called *lattices*.

Let  $\Gamma$  be a lattice in  $V$  such that  $V = \langle \Gamma \rangle$ . Then the subgroup of  $V^*$

$$\Gamma^* = \{\lambda \in V^*: \lambda(x) \in \mathbb{Z} \text{ for all } x \in \Gamma\}$$

is also a lattice and generates  $V^*$ . Indeed, let  $e_1, \dots, e_n$  be a basis of  $V$ ; by the definition this basis is a basis of  $V$ . In  $V^*$ , consider the dual basis  $e_1^*, \dots, e_n^*$  given by the formulas  $e_i^*(e_j) = \delta_{ij}$ . Then, clearly,  $e_1^*, \dots, e_n^*$  is a basis of  $V^*$ . The lattice  $\Gamma^*$  is naturally identified with the group  $\text{Hom}(\Gamma, \mathbb{Z})$ ; it is called the *dual lattice* of  $\Gamma$ . If we naturally identify  $V$  with  $(V^*)^*$ , then  $\Gamma$  is identified with  $(\Gamma^*)^*$ .

Let  $\Gamma \subset \tilde{\Gamma}$  be two lattices in  $V$ . Then  $\tilde{\Gamma}/\Gamma$  is a finitely generated abelian group which can be described as follows. Consider a basis  $\gamma_1, \dots, \gamma_l$  of  $\Gamma$  and a basis  $\tilde{\gamma}_1, \dots, \tilde{\gamma}_m$  of  $\tilde{\Gamma}$ . Then

$$\gamma_i = \sum_{1 \leq j \leq m} c_{ji} \tilde{\gamma}_j \quad (i = 1, \dots, l),$$

where  $C = (c_{ij})$  is a matrix with integer entries. It is known (see [3]) that

$$\tilde{\Gamma}/\Gamma \simeq \bigoplus_{1 \leq i \leq s} \mathbb{Z}_{m_i} \oplus \mathbb{Z}^{m-l},$$

where  $m_1 | m_2 | \dots | m_s$  are the invariant factors of  $C$  different from 0 and 1. In particular, if  $l = m$  then  $\tilde{\Gamma}/\Gamma$  is finite and

$$|\tilde{\Gamma}/\Gamma| = |\det C|.$$

**Problem 63.** If  $\Gamma \subset \tilde{\Gamma}$  are lattices in  $V = \langle \Gamma \rangle = \langle \tilde{\Gamma} \rangle$  then  $\tilde{\Gamma}^* \subset \Gamma^*$  and  $\tilde{\Gamma}/\Gamma \simeq \Gamma^*/\tilde{\Gamma}^*$ .

Let  $\Delta$  be a root system in a Euclidian space  $\mathbb{E}$ . Denote by  $Q$  the additive subgroup of  $\mathbb{E}$  generated by  $\Delta$ . If  $\Pi$  is an arbitrary base of  $\Delta$  then  $\Pi$  is a basis of the abelian group  $Q$ . Therefore  $Q$  is the lattice with basis  $\Pi$ . It is called the *root lattice*.

Further, let  $\mathbb{E} = \langle \Delta \rangle$  and set

$$P = \{ \gamma \in \mathbb{E} : \langle \gamma | \alpha \rangle \in \mathbb{Z} \quad \text{for all } \alpha \in \Delta \}.$$

Let  $\Pi = \{ \alpha_1, \dots, \alpha_l \}$ . Determine  $\pi_i \in P$  by the formula

$$\langle \pi_i | \alpha_j \rangle = \delta_{ij}.$$

Clearly,  $P$  is a lattice with basis  $\pi_1, \dots, \pi_l$ ; this lattice is called the *weight lattice* and its elements are called *weights*. The weights  $\pi_1, \dots, \pi_l$  are called *fundamental weights* (with respect to  $\Pi$ ). Simple roots are expressed in terms of fundamental weights by formula

$$\alpha_i = \sum_{1 \leq j \leq l} a_{ij} \pi_j, \quad (6)$$

where  $A = (a_{ij})$  is the Cartan matrix of  $\Delta$ .

**Problem 64.** The lattices  $Q$  and  $P$  are invariant with respect to the Weyl group  $W^\vee$ .

The definition of a root system implies that  $Q \subset P$ . The group  $\pi(\Delta) = P/Q$  is called the *fundamental group* of  $\Delta$ .

**Problem 65.** The fundamental group  $\pi(\Delta)$  is isomorphic to  $\bigoplus_{1 \leq i \leq s} \mathbb{Z}_{m_i}$ , where  $m_i$  are the invariant factors of the Cartan matrix  $A$  of  $\Delta$  different from 1. In particular,

$$|\pi(\Delta)| = \det A.$$

In Table 3 are listed the fundamental groups  $\pi(\Delta)$  of all indecomposable reduced root systems  $\Delta$  calculated with the help of Problem 65. Notice that  $\pi(\Delta)$  is a cyclic group in all cases except when  $\Delta$  is of the type  $D_{2s}$ ,  $s \geq 2$ .

Consider also the dual root system  $\Delta^\vee \subset \mathbb{F} = \mathbb{E}^*$ . The root and weight lattices  $Q^\vee \subset P^\vee$  in the space  $\mathbb{F}$  correspond to it. By Problem 64 they are invariant with respect to the Weyl group  $W = (W^\vee)^\vee$ .

**Problem 66.**  $Q^\vee = P^*$ ,  $P^\vee = Q^*$ ,  $\pi(\Delta^\vee) \simeq \pi(\Delta)$ .

By Problem 1.29 our constructions are applicable in the case when  $\Delta = \Delta_G$  is a root system of a semisimple algebraic group  $G$  with respect to a maximal torus  $T$ . As we have seen in 1.4°, the group  $\mathcal{X}(T)$  is identified with a lattice in the space  $\mathbb{E} = \mathfrak{t}(\mathbb{R})^*$ . Its dual lattice  $\mathcal{X}(T)^* \subset (\mathbb{R})$  coincides with  $\mathfrak{t}(\mathbb{Z})$ .

**Problem 67.**  $Q \subset \mathcal{X}(T) \subset P$  and  $Q^\vee \subset \mathfrak{t}(\mathbb{Z}) \subset P^\vee$ .

Notice that the lattices  $P$ ,  $Q$ ,  $P^\vee$ ,  $Q^\vee$  are determined by the root system  $\Delta_G = \Delta_{\mathfrak{g}}$  which, as we have seen above, does not depend on the choice of an algebraic group  $G$  with tangent algebra  $\mathfrak{g}$ . At the same time,  $\mathcal{X}(T)$  and  $\mathfrak{t}(\mathbb{Z})$  depend, in general, not only on  $\mathfrak{g}$  but also on the global structure of  $G$ . In §3 we will show that a connected semisimple algebraic group  $G$  is determined up to an isomorphism by the root system  $\Delta_G$  and any of the lattices  $\mathcal{X}(T)$ ,  $\mathfrak{t}(\mathbb{Z})$ .

If  $\rho$  is a linear representation of a semisimple Lie algebra  $\mathfrak{g}$  then  $\Phi_\rho \subset P$  (see Problem 1.43), i.e. any weight of  $\rho$  is a weight in the above sense.

### Exercises

Let  $\mathbb{E}$  be a finite dimensional Euclidian space,  $O(\mathbb{E})$  the group of all its orthogonal transformations and  $I(\mathbb{E})$  the group of its isometries. If  $\Omega \subset \mathbb{E}$  is a finite system of nonzero vectors then  $\text{Aut } \Omega$  denotes the group of all automorphisms of  $\Omega$  in the sense of 1°. In Exercises 3–19 we assume that  $\Delta$  is a root system in  $\mathbb{E}$  and  $\Pi$  a fixed base of  $\Delta$ . We denote the Weyl group of  $\Delta$  by  $W$  and the Weyl group of the dual root system by  $W^\vee$ ; the root and weight lattices are denoted by  $Q$  and  $P$ , respectively.

- 1) If  $\Omega$  is indecomposable then  $\text{Aut } \Omega \subset O(\langle \Omega \rangle)$ .
- 2) If  $\Omega$  is admissible then  $\text{Aut } \Omega$  is isomorphic to the group of automorphisms of the Dynkin diagram of  $\Omega$ .
- 3) The scalar product in  $\mathbb{E}$  may be redefined so that in the new Euclidian space  $\tilde{\mathbb{E}}$ , the system  $\Delta_i$  would become a root system and  $\text{Aut } \Delta \subset O(\langle \Delta \rangle)$ .
- 4) If  $\alpha \in \Pi$  then  $r_\alpha$  maps  $\Delta^+ \setminus \{\alpha, 2\alpha\}$  into itself.
- 5) Let  $\Delta$  be reduced and  $\rho = \frac{1}{2} \sum_{\alpha \in \Delta^+} \alpha$ . Then  $r_\beta(\rho) = \rho - \beta$  and  $\langle \rho | \beta \rangle = 1$  for

all  $\beta \in \Pi$ , hence  $\rho$  coincides with the sum  $\pi_1 + \dots + \pi_l$  of all fundamental weights.

- 6) Let  $\Delta$  be reduced,  $w \in W^\vee$  and  $t = l(w)$  (cf. Problem 38). Then  $t$  coincides with the number of the  $\alpha \in \Delta^+$  such that  $w(\alpha) < 0$ .
- 7) A root system  $\Delta$  is indecomposable if and only if  $W$  acts irreducibly on  $\langle \Delta^\vee \rangle$ .
- 8) An indecomposable reduced root system contains roots of only one or two different lengths and the Weyl group acts transitively on the set of all roots of the same length.
- 9) Roots of the maximal and minimal length of an indecomposable reduced root system  $\Delta$  form two root systems  $\Delta_{\max}$  and  $\Delta_{\min}$  of the same rank as  $\Delta$ . If  $\Delta$  contains roots of two different lengths then  $\Delta_{\max}$  and  $\Delta_{\min}$  are determined by the following table:

$\Delta$	$B_l, l \geq 2$	$C_l, l \geq 2$	$F_4$	$G_2$
$\Delta_{\min}$	$D_l$	$A_1 + \dots + A_1$ ( $l$ summands)	$D_4$	$A_2$
$\Delta_{\max}$	$A_1 + \dots + A_1$ ( $l$ summands)	$D_l$	$D_4$	$A_2$

(we denote  $D_2 = A_1 + A_1$ ).

- 10) Under the conditions of Exercise 9 the highest root of  $\Delta$  belongs to  $\Delta_{\max}$ . In  $\Delta_{\min}$  there exists a unique maximal element (the *highest short root*).
- 11) The indecomposable components  $(\Delta^\vee)_i$  of the root system dual to  $\Delta$  are  $(\Delta_i)^\vee$ , where the  $\Delta_i$  are the indecomposable components of  $\Delta$ . If  $\Delta$  is an indecomposable root system different from  $B_n$  and  $C_n$ ,  $n \geq 3$ , then  $\Delta^\vee \simeq \Delta$ . Moreover,  $B_n^\vee \simeq C_n$ .
- 12) Under the conditions of Exercise 9  $(\Delta_{\max})^\vee = (\Delta^\vee)_{\min}$  and  $(\Delta_{\min})^\vee = (\Delta^\vee)_{\max}$ . If  $\alpha_0$  is the highest root (with respect to  $\Pi$ ) then  $\alpha_0^\vee$  is the highest short root (with respect to  $\Pi^\vee$ ) and vice versa.
- 13) The group  $W$  does not contain reflections with respect to hyperplanes different from  $P_\alpha$ ,  $\alpha \in \Delta$ .
- 14) If  $w \in W^\vee$  preserves  $\gamma \in E$  then  $w$  can be presented as a product of reflections  $r_\alpha$  ( $\alpha \in \Delta$ ) each preserving  $\gamma$ .
- 15)  $\text{Aut } \Delta = W^\vee \rtimes \text{Aut } \Pi$ .
- 16) If  $\text{Aut } \Pi$  is trivial then  $-e \in W$ . (Hint: make use of the opposite Weyl chamber.)
- 17) Calculate the Weyl groups  $W$  of  $\mathfrak{g} = \mathfrak{so}_n(\mathbb{C})$  ( $n \geq 3$ ),  $\mathfrak{sp}_{2n}(\mathbb{C})$  ( $n \geq 1$ ) and compare the results with Table 4. Prove that  $-e \in W$  if  $\mathfrak{g} = \mathfrak{sl}_2(\mathbb{C})$ ,  $\mathfrak{so}_{2n+1}(\mathbb{C})$  ( $n \geq 1$ ),  $\mathfrak{so}_{4n}(\mathbb{C})$  ( $n \geq 1$ ) and  $-e \notin W$  if  $\mathfrak{g} = \mathfrak{sl}_n(\mathbb{C})$  ( $n \geq 3$ ) and  $\mathfrak{g} = \mathfrak{so}_{4n+2}(\mathbb{C})$  ( $n \geq 1$ ).
- 18) Each automorphism  $a \in \text{Aut } \Delta$  transforms the lattices  $Q$  and  $P$  into themselves and therefore induces an automorphism  $\tilde{a}$  of the group  $\pi(\Delta)$ . If  $a \in W^\vee$  then  $\tilde{a} = e$ . This implies that if  $-e \in W$  then the order of any element of  $\pi(\Delta)$  is  $\leq 2$ .

19) Let  $\Delta$  be an indecomposable reduced root system. Then  $-e \notin W$  if  $\Delta$  is of the type  $A_n$  ( $n \geq 2$ ),  $D_{2n+1}$  ( $n \geq 1$ ),  $E_6$  and  $-e \in W$  otherwise.

An algebraic subgroup  $P$  of a connected algebraic group  $G$  is *parabolic* if  $G/P$  is a projective algebraic variety. The corresponding subalgebra  $\mathfrak{p}$  of the tangent algebra  $\mathfrak{g}$  of  $G$  is also called *parabolic*.

20) A subgroup  $P \subset G$  is parabolic if and only if  $P$  contains a Borel subgroup of  $G$ . A parabolic subalgebra of a semisimple Lie algebra is regular.

Let  $G$  be a connected reductive complex algebraic group,  $T$  a torus in  $G$  and  $x_0 \in \mathfrak{t}(\mathbb{R})$ . Consider the root decomposition of  $\mathfrak{g}$  with respect to  $T$  and let  $H, N^+, P^+$  be the connected algebraic subgroups of  $G$  corresponding to the algebraic subalgebras  $\mathfrak{h} = \bigoplus_{\alpha(x_0)=0} \mathfrak{g}_\alpha$ ,  $\mathfrak{n}^+ = \bigoplus_{\alpha(x_0)>0} \mathfrak{g}_\alpha$  and  $\mathfrak{p}^+ = \mathfrak{h} \oplus \mathfrak{n}^+$ .

21)  $P^+$  is a parabolic subgroup of  $G$ .

22)  $P^+$  coincides with its normalizer; the coset space  $G/P^+$  is simply connected.

23)  $P^+$  is the semidirect product of the reductive subgroup  $H$  and the unipotent normal subgroup  $N^+$ .

24) If  $\alpha(x_0) \neq 0$  for all  $\alpha \in \Delta(T)$  then  $H = N(T) \cap P^+$  and  $H$  coincides with the centralizer of  $T$ .

Let  $T$  be a maximal torus in a connected reductive algebraic group  $G$ ,  $\Delta_G$  the corresponding root system and  $\Pi \subset \Delta_G$  a base. Let  $M \subset \Pi$  be a set of simple roots. Denote by  $\Delta^+(M)$  the set consisting of all positive roots and the negative roots which are linearly expressed in terms of simple roots from  $M$ .

25) The subset  $\Delta^+(M) \subset \Delta_G$  is closed.

Set  $\mathfrak{p}^{(M)} = \mathfrak{g}(\Delta^+(M), \mathfrak{t})$  (see Exercise 1.21).

26) The connected algebraic subgroup  $P^{(M)}$  of  $G$  corresponding to  $\mathfrak{p}^{(M)} \subset \mathfrak{g}$  is parabolic; any parabolic subgroup is conjugate to a unique subgroup of this form.

27) Any parabolic subgroup of  $G$  can be obtained by the method described just before the Exercise 21, where for  $T$  one can take a maximal torus.

28) Let  $\mathfrak{g}$  be a semisimple complex Lie algebra. Select basis elements  $e_\alpha \in \mathfrak{g}_\alpha$  ( $\alpha \in \Delta_\mathfrak{g}$ ) as in 1.6°. Set  $h = \sum_{\alpha \in \Delta^+} h_\alpha$ . Then  $h = \sum_{\beta \in \Pi} r_\beta h_\beta$ , where  $r_\beta$  are positive integers. If

$$e_+ = \sum_{\beta \in \Pi} \sqrt{r_\beta} e_\beta, \quad e_- = \sum_{\beta \in \Pi} \sqrt{r_\beta} e_{-\beta},$$

then  $\langle h, e_+, e_- \rangle$  is a simple three-dimensional subalgebra of  $\mathfrak{g}$  (called the *principal three-dimensional subalgebra*).

A subsystem  $\Gamma$  of a root system  $\Delta$  is called *symmetric* if  $-\alpha \in \Gamma$  for any  $\alpha \in \Gamma$ . As in § 1  $\Gamma$  is called *closed* if  $\alpha, \beta \in \Gamma$ ,  $\alpha + \beta \in \Delta$  imply  $\alpha + \beta \in \Gamma$ . Exercises 1.21, 1.22, 1.24, 1.25 determine a one-to-one correspondence between the classes of conjugate semisimple regular subalgebras of a semisimple Lie algebra  $\mathfrak{g}$  and the closed symmetric subsystems of  $\Delta_\mathfrak{g}$  considered up to the action of the Weyl group.

In Exercises 29–38  $\Delta$  denotes a reduced root system. A subsystem  $\Gamma \subset \Delta$  is called a  $\pi$ -system if  $\alpha - \beta \notin \Delta$  for any  $\alpha, \beta \in \Gamma$ . For any subsystem  $M \subset \Delta$  denote by  $[M]$  the set of all roots  $\Delta$  which are linear combinations of the roots of  $M$  with integer coefficients. Let  $l$  be the rank of  $\Delta$ ,  $W$  its Weyl group.

- 29) Any  $\pi$ -system is an admissible system of vectors.
- 30) Any symmetric closed subsystem  $M \subset \mathcal{A}$  is a root system. Any base  $\Gamma \subset M$  is a  $\pi$ -system and  $M = [\Gamma]$ . Conversely, if  $\Gamma \subset \mathcal{A}$  is a linearly independent  $\pi$ -system then  $M = [\Gamma]$  is a symmetric closed subsystem and  $\Gamma$  is a base of  $M$ .
- 31) Linearly independent  $\pi$ -systems  $\Gamma_1, \Gamma_2 \subset \mathcal{A}$  can be transformed into each other by an element of  $W^\vee$  if and only if so can  $[\Gamma_1]$  and  $[\Gamma_2]$ .
- 32) Let  $\Gamma \subset \mathcal{A}$  be a linearly independent  $\pi$ -system. Then the system  $\tilde{\Gamma}$  obtained from  $\Gamma$  by adjoining the corresponding lowest roots to some of its indecomposable components is also a  $\pi$ -system.
- 33) Any indecomposable  $\pi$ -system is isomorphic either to a base or to an extended base of a root system.
- 34) If  $\Gamma \subset \mathcal{A}$  is indecomposable and admissible then  $\Gamma$  is a  $\pi$ -system.
- 35) Any linearly independent  $\pi$ -system in  $\mathcal{A}$  is contained in a linearly independent  $\pi$ -system consisting of  $l$  elements.

Let  $\Gamma \subset \mathcal{A}$  be a linearly independent  $\pi$ -system and  $\Gamma'$  a  $\pi$ -system obtained by adjoining to an indecomposable component  $\Gamma_1$  of  $\Gamma$  the corresponding lowest root  $\alpha_0$ . Set  $\Gamma' = \tilde{\Gamma} \setminus \{\alpha\}$ , where  $\alpha \in \Gamma_1$ . One says that the  $\pi$ -system  $\Gamma'$  is obtained from  $\Gamma$  by an *elementary transformation*.

- 36) We have  $[\Gamma'] \subset \Gamma$  and these systems coincide if and only if  $\alpha$  occurs in the expression for  $-\alpha_0$  with coefficient 1.
- 37) Any linearly independent  $\pi$ -system in  $\mathcal{A}$  consisting of  $l$  elements can be obtained from a base  $\Pi \subset \mathcal{A}$  by a sequence of elementary transformations.
- 38) If  $\mathcal{A} = \mathcal{A}_1 \cup \cdots \cup \mathcal{A}_r$  is a decomposition of  $\mathcal{A}$  into indecomposable components then a subsystem  $M \subset \mathcal{A}$  is symmetric and closed if and only if  $M \cap \mathcal{A}_i$  is a symmetric closed subsystem of  $\mathcal{A}_i$  for any  $i = 1, \dots, r$ .

In Exercises 39–43 we assume that  $\mathcal{A}$  is indecomposable,  $\Pi = \{\alpha_1, \dots, \alpha_l\}$  its base,  $\alpha_0$  the lowest root,  $-\alpha_0 = \sum_{1 \leq i \leq l} n_i \alpha_i$ ,  $\tilde{\Pi} = \{\alpha_0, \alpha_1, \dots, \alpha_l\}$ .

- 39) We have  $n_i = 1 \Leftrightarrow \tilde{\Pi} \setminus \{\alpha_i\}$  is a base of  $\mathcal{A} \Leftrightarrow$  there exists  $w \in W^\vee$  such that  $w(\tilde{\Pi}) = \tilde{\Pi}$  and  $w(\alpha_0) = \alpha_i$ .
- 40) Any maximal symmetric closed subsystem of  $\mathcal{A}$  is of rank  $l$  or  $l - 1$ .
- 41) Let  $\Gamma \subset \mathcal{A}$  be a linearly independent  $\pi$ -system consisting of  $l$  elements. If  $[\Gamma]$  is a maximal closed symmetric subsystem of  $\mathcal{A}$  then  $\Gamma$  is obtained from a base  $\Pi \subset \mathcal{A}$  by applying one elementary transformation.
- 42) Let  $\Gamma = \tilde{\Pi} \setminus \{\alpha_i\}$ , where  $i > 0$ . A symmetric closed system  $[\Gamma]$  is maximal if and only if  $n_i$  is prime. (Hint: see [5], §8.3).
- 43) Let  $\Gamma \subset \mathcal{A}$  be a linearly independent  $\pi$ -system of  $l - 1$  elements. A symmetric closed subsystem  $[\Gamma]$  is maximal if and only if  $\Gamma = \Pi \setminus \{\alpha_i\}$ , where  $\Pi$  is a base of  $\mathcal{A}$  and  $n_i = 1$ .

### Hints to Problems

2. Similar to Problem 1.35.
7. Make use of Problems 1.31, 1.32.

9. Let  $(\alpha, \beta) > 0$ . By Problem 8 we may assume that  $\langle \alpha | \beta \rangle = 1$  which, thanks to Problem 1, implies  $\alpha - \beta = r_\beta(\alpha) \in \Delta$ . 24  
25
10. Let  $p, q$  be the maximal nonnegative integers such that  $\beta - p\alpha, \beta + q\alpha \in \Delta$ . Problem 9 implies that the  $\alpha$ -string through  $\beta$  has no gaps (i.e.  $\beta + k\alpha \in \Delta$  for all  $k, -p \leq k \leq q$ ). Since the  $\alpha$ -string is invariant with respect to  $r_\alpha$  (and therefore  $r_\alpha(\beta + q\alpha) = \beta - p\alpha$ ), then  $p - q = \langle \beta | \alpha \rangle$ . 26
11. Make use of formula (1). In particular, prove that

$$(r_\alpha(\beta))^\vee = r_{\alpha^\vee}(\beta^\vee) \quad (\alpha, \beta) \in \Delta.$$

13. Consider the cases  $\alpha - \beta \in \Delta^+$  and  $\alpha - \beta \in \Delta^-$  and apply Problem 9. 27
14. Set  $v = a_1 v_{i_1} + \cdots + a_k v_{i_k} = b_1 v_{j_1} + \cdots + b_l v_{j_l}$ . Considering  $(v, v)$  we derive from  $(v_{i_p}, v_{j_q}) \leq 0$  that  $v = 0$  and  $(v_{i_p}, v_{j_q}) = 0$  for all  $p, q$ . Let  $u$  be a vector such that  $(u, v_i) > 0$  ( $i = 1, \dots, s$ ). Then  $(u, v) = 0$  implies  $a_p = b_q = 0$  for all  $p, q$ . 28
15. Let  $C_1 = \{x \in F : \alpha(x) > 0 \text{ for all } \alpha \in \Pi(C)\}$ . Clearly,  $C \subset C_1$ . But  $C_1 \subset F_{\text{reg}}$  and  $C_1$  is convex and therefore connected, hence  $C = C_1$ . 29
17. By Problem 16  $C$  is a nonempty connected subset of  $F_{\text{reg}}$ . Therefore  $C \subset C_1$ , where  $C_1$  is a Weyl chamber. Clearly, the set  $\Delta^+$  of positive (with respect to  $\Pi$ ) roots coincides with the set of  $C_1$ -positive roots implying  $\Pi \subset \Pi(C_1)$ . Therefore  $\Pi = \Pi(C_1)$  and by Problem 15  $C = C_1$ . 30
18. Let  $x \in F$  be such that  $\alpha(x) \geq 0$  for all  $\alpha \in \Pi(C)$ . If we fix  $x_0 \in C$  then Problem 15 implies that  $x + (x_0/n) \in C$  for all  $n = 1, 2, \dots$ . Therefore  $x \in \bar{C}$ . Applying Problem 16 to the restrictions of linear forms of  $\Pi(C) \setminus \{\alpha\}$  onto the hyperplane  $P_\alpha$  for some  $\alpha \in \Pi(C)$ , we see that  $P_\alpha \cap \bar{C}$  contains a nonempty open set, i.e.  $P_\alpha$  is a wall of  $C$ . Conversely, if  $P$  is a wall then  $P$  contains an open ball  $U$  such that  $U \subset \bar{C} \setminus C \subset \bigcup_{\alpha \in \Pi(C)} P_\alpha$ . We see that  $P \subset \bigcup_{\alpha \in \Pi(C)} P_\alpha$ . Therefore  $P$  coincides with one of the hyperplanes  $P_\alpha$ . 31
19. Within the open set  $F \setminus \bigcup_{\beta \in \Delta, \beta \neq c_\alpha} P_\beta$  choose a ball  $U$  such that  $U \cap P_\alpha \neq \emptyset$ . The component  $U_1 = \{x \in U : \alpha(x) > 0\}$  of  $U \setminus P_\alpha$  is contained in a Weyl chamber  $C$  for which  $P_\alpha$  is a wall. By Problem 18  $\alpha = c\beta$ , where  $\beta \in \Pi(C)$  and  $c > 0$ . Next apply Problem 2. 32
20. If  $(\alpha, \beta) \leq 0$  for all  $\beta \in \Pi$ , we get a contradiction with Problem 14. Next apply Problem 9. Since all the coefficients of the expression of  $\alpha - \beta$  in terms of simple roots should be of the same sign, then  $\alpha - \beta > 0$ . 33
22. Let  $\Pi \subset \Delta$  be a base. If  $\Delta = \Delta_1 \cup \Delta_2$ , where  $\Delta_1 \neq \emptyset, \Delta_2 \neq \emptyset$ , and  $(\alpha, \beta) = 0$  for all  $\alpha \in \Delta_1, \beta \in \Delta_2$  then  $\Pi = (\Pi \cap \Delta_1) \cup (\Pi \cap \Delta_2)$ . We have  $\Pi \cap \Delta_1 \neq \emptyset$  and  $\Pi \cap \Delta_2 \neq \emptyset$  since  $\Pi$  is a basis of  $\langle \Delta \rangle$ . Conversely, let  $\Pi = \Pi_1 \cup \Pi_2$ , where  $\Pi_1 \neq \emptyset, \Pi_2 \neq \emptyset$  and  $(\alpha, \beta) = 0$  for all  $\alpha \in \Pi_1, \beta \in \Pi_2$ . Denote by  $\Delta_i$  the set of roots of  $\Delta$  linearly expressible in terms of  $\Pi_i$  ( $i = 1, 2$ ). Let us show that  $\Delta = \Delta_1 \cup \Delta_2$ . If this is not so, Problem 21 implies that there exist  $\alpha \in \Delta_1 \cap \Delta^+$  and  $\beta \in \Pi_2$  (or  $\alpha \in \Delta_2 \cap \Delta^+$  and  $\beta \in \Pi_1$ ) such that  $\gamma = \alpha + \beta \in \Delta$ . Since  $\alpha - \beta \notin \Delta$ , then  $(\alpha, \beta) > 0$  by Problem 10. Contradiction. 34
23. To prove the linear independence of  $\Pi$  first show that the statement of Problem 13 holds for  $\Pi$  and then apply Problem 1.

24. Make use of Problem 18.
25. By Problem 1.26  $(\mathfrak{n}^+, \mathfrak{n}^+) = 0$  hence  $\mathfrak{n}^+$  is a solvable Lie algebra. Since  $\mathfrak{b}^+/\mathfrak{n}^+ \simeq \mathfrak{t}$ , then  $\mathfrak{b}^+$  is also solvable. Clearly,  $\mathfrak{n}^+ = [\mathfrak{b}^+, \mathfrak{b}^+]$  implying the unipotency of  $\mathfrak{n}^+$ .
26. Since  $\mathfrak{b}^+ \supset \mathfrak{t}$ , then any subalgebra  $\mathfrak{h} \subset \mathfrak{g}$  containing  $\mathfrak{b}^+$  is of the form  $\mathfrak{h} = \mathfrak{b}^+ \oplus \bigoplus_{\alpha \in \Delta^+} \tilde{\mathfrak{g}}_{-\alpha}$ , where  $\tilde{\mathfrak{g}}_{-\alpha}$  is a subspace of  $\mathfrak{g}_{-\alpha}$ . The existence of simple three-dimensional subalgebras constructed in 1.6° implies that  $\mathfrak{h}$  cannot be solvable except for  $\mathfrak{h} = \mathfrak{b}^+$ . To prove the second statement of the problem, it suffices to notice that if  $\tilde{\mathfrak{g}}_{-\alpha} \neq 0$  then  $[\tilde{\mathfrak{g}}_{-\alpha}, \mathfrak{t}] = \mathfrak{g}_{-\alpha} \not\subset \mathfrak{b}^+$ .
27. Problem 25 implies that  $TN^+ = T \times N^+$  is an algebraic subgroup of  $B^+$ . This subgroup coincides with  $B^+$  since  $\mathfrak{b}^+$  is its tangent algebra.
28. If  $B_1, B_2$  are the Borel subgroups corresponding to the Weyl chambers  $C_1, C_2$  then  $B_1 = B_2$  implies that the unipotent radicals of these subgroups coincide. Making use of Problem 27 we deduce that the sets of  $C_1$ -positive and  $C_2$ -positive roots coincide. Now apply Problem 15.
29. By Theorem 3.2.12 there exists  $g \in G$  such that  $gBg^{-1} = B^+$ . Then  $gTg^{-1} \subset B^+$  and by Problem 3.2.23 there exists  $b \in B^+$  such that  $b(gTg^{-1})b^{-1} = T$ . Set  $a = bg$ .
30. The algebraic group  $N^- \cap G_p = H$  is unipotent and therefore irreducible (Corollary 2 of Theorem 3.2.1). On the other hand, its tangent algebra is  $\mathfrak{n}^- \cap \mathfrak{b}^+ = 0$ . Therefore,  $H = \{e\}$ . By Problem 2.1.20  $\alpha_p: N^- \rightarrow N^-(p)$  is an isomorphism. Since  $\mathfrak{g} = \mathfrak{b}^+ \oplus \mathfrak{n}^-$ , then  $\dim D = \dim N^- = \dim N^-(p)$  and the orbit  $N^-(p)$  is open in  $D$ .
31. Consider the manifold  $G/N(B)$  endowed with a quasiprojective algebraic variety structure such that the canonical  $G$ -action on it is algebraic. By Problem 25  $N(B)^0 = B$ . Therefore, it suffices to prove that  $G/N(B)$  is simply connected which one does as in the proof of Theorem 4.
32. By Problem 3.2.21 the subgroup  $N_B(T)$  is irreducible and it is contained in the centralizer of  $T$ . Now, apply Problem 1.28.
33. First prove that the centralizer of  $T$  is contained in  $N(B^+)$ .
34. The elements of  $W^\vee$  are expressed by matrices with integer entries in the basis consisting of simple roots.
35. First prove that the set obtained by deleting from  $F$  the union of all the pairwise intersections of the hyperplanes  $P_\alpha$  ( $\alpha \in \Delta$ ) is simply connected.
36. Let  $C$  and  $C'$  be two Weyl chambers and  $C = C_0, C_1, \dots, C_r = C'$  the sequence of Weyl chambers constructed in Problem 35. We may assume that  $\Pi = \Pi(C)$ . By induction in  $r$  prove the existence of  $w \in W'$  such that  $C' = w(C)$ . Let exist  $w_0 \in W'$  such that  $w_0(C) = C_{r-1}$ . Let  $p_\alpha$ , where  $\alpha \in \Delta$  and  $\frac{1}{2}\alpha \notin \Delta$ , be the common wall of  $C_{r-1}$  and  $C_r = C'$ . Then  $w_0^{-1}(p_\alpha) = p_{\alpha_0}$ , where  $\alpha_0 \in \Pi$ . Furthermore,  $r_\alpha = w_0 r_{\alpha_0} w_0^{-1} \in W'$  and  $(r_\alpha w_0)C = C'$ .
37. It suffices to prove that  $r_\alpha \in W'$  for any  $\alpha \in \Delta$ . For this make use of Problems 19 and 36.
40. We may assume that  $\mathbf{E} = \langle \Delta \rangle$ ,  $\mathbf{E}' = \langle \Delta' \rangle$ . Problem 1 implies that  $r_{\varphi(\alpha)} = \varphi r_\alpha \varphi^{-1}$  for any  $\alpha \in \Pi$ . Applying Theorem 7 we see that the map  $w \mapsto \varphi w \varphi^{-1}$  is an injective homomorphism of the Weyl groups  $W^\vee \rightarrow W'^\vee$  corre-

sponding to  $\Delta$  and  $\Delta'$ . By the same Theorem 7 any  $\alpha \in \Delta$  presents in the form  $\alpha = w(\gamma)$ , where  $w \in W^\vee$ ,  $\gamma \in \Pi$ . Hence  $\varphi(\alpha) = (\varphi w \varphi^{-1})(\varphi(\gamma)) \in \Delta'$ . Making use of Problem 1 again, it is easy to show that  $\langle \varphi(\alpha) | \varphi(\beta) \rangle = \langle \alpha | \beta \rangle$  for all  $\alpha, \beta \in \Delta$ . When  $\Delta'$  is a reduced root system and  $\Pi' = \varphi(\Pi)$  is its base, apply the above to  $\varphi^{-1}$ .

41. Make use of Theorem 6.
42. Let  $n \in N(T)$  and let the corresponding transformation  $w$  map the Weyl chamber  $C$  into itself. Then  $nBn^{-1} = B$ , where  $B$  is the Borel subgroup corresponding to  $C$ . Applying Theorem 4 and Problem 1 we see that  $n \in T$  and  $w = e$ . Thus  $W''$  acts simply transitively on the Weyl chambers. Since any transitive subgroup of a simply transitive group coincides with the latter, we have  $W = W''$ .
43. If Dynkin diagrams of the systems  $\Gamma = \{\gamma_1, \dots, \gamma_r\}$  and  $\Gamma' = \{\gamma'_1, \dots, \gamma'_r\}$  are isomorphic then there exists a bijection  $\varphi: \Gamma \rightarrow \Gamma'$  such that  $\varphi(\gamma_i) = \gamma'_i$ ,  $a_{ij} = a'_{ij}$  ( $i, j = 1, \dots, r$ ), where  $a_{ij} = \langle \gamma_i | \gamma_j \rangle$ ,  $a'_{ij} = \langle \gamma'_i | \gamma'_j \rangle$ . We may assume that  $\gamma_1, \dots, \gamma_r$  is a maximal linearly independent subsystem of  $\Gamma$ . Considering the principal minors of  $A(\Gamma)$  and  $A(\Gamma')$  it is easy to see that  $\gamma'_1, \dots, \gamma'_r$  is a maximal linearly independent subsystem of  $\Gamma'$ .

Therefore there exists a linear isomorphism  $f: \langle \Gamma \rangle \rightarrow \langle \Gamma' \rangle$  such that  $f(\gamma_i) = \varphi(\gamma_i)$  for  $i = 1, \dots, r$ . We then prove that this holds for  $i = r+1, \dots, s$ , too. For this it suffices to verify that for any  $k$  such that  $r+1 \leq k \leq s$  the coefficients  $c_i$  in the expression  $\gamma_k = \sum_{1 \leq i \leq r} c_i \gamma_i$  are completely determined by the principal submatrix of  $A(\Gamma)$  corresponding to the subsystem  $\gamma_1, \dots, \gamma_r, \gamma_k$ . But these coefficients constitute the unique solution of the system  $\sum_{1 \leq i \leq r} \langle \gamma_i | \gamma_j \rangle c_i = \langle \gamma_k | \gamma_j \rangle$  ( $j = 1, \dots, r$ ).

44. Make use of (1).
45. Make use of Problem 14.
46. Make use of Problems 9, 10 and 20.
47. The inequalities  $n_\alpha > 0$  follow from Problem 45 applied to the system  $\Pi \cup \{-\delta\}$ . If  $\delta'$  is another maximal root then it follows from Problem 46 that  $\langle \delta', \delta \rangle > 0$ . If  $\delta \neq \delta'$  then with the help of Problem 9 we get a contradiction.
48. Let  $b$  be a bilinear form in  $\mathbb{R}^l$  with matrix  $G$  in the standard basis  $e_1, \dots, e_l$ . Consider the images of the vectors  $e_1, \dots, e_l$  in the space  $E = \mathbb{R}^l/N$  where  $N$  is the kernel of  $b$ .
50. It suffices to consider the case when  $A$  is indecomposable. For any  $i = 2, \dots, l$  there exists a unique sequence of numbers  $1 = i_0, i_1, \dots, i_k = i$  such that  $a_{i_p i_{p+1}} \neq 0$  for  $p = 0, 1, \dots, k-1$ . Set

$$p_i = \sqrt{\frac{a_{i_1 i_1} a_{i_2 i_1} \cdots a_{i_k i_{k-1}}}{a_{1 i_1} a_{i_1 i_2} \cdots a_{i_{k-1} i_k}}} \quad (i \geq 2), \quad p_1 = 1$$

and note that  $p_i^2/p_j^2 = a_{ij}/a_{ji}$  for any  $i, j$ . Since  $p_i^2 \in \mathbb{Q}$ , then  $(\gamma_i, \gamma_j) \in \mathbb{Q}$  for all  $i, j$ .

51. If the Dynkin diagram is a cycle then

$$A = \begin{pmatrix} 2 & a_{12} & \dots & 0 & a_{1l} \\ a_{21} & 2 & \dots & 0 & 0 \\ \dots & \dots & \dots & \dots & \dots \\ 0 & 0 & & 2 & a_{l-1,l} \\ a_{l1} & 0 & \dots & a_{l,l-1} & 2 \end{pmatrix}$$

and  $m_{12}, m_{23}, \dots, m_{l-1,l}, m_{l1}$  are positive integers. Since the sum of all elements of a positive semi-definite matrix is nonnegative, we get from (5)  $l - (\sqrt{m_{12}} + \dots + \sqrt{m_{l-1,l}} + \sqrt{m_{l1}}) \geq 0$ . It follows that  $m_{12} = \dots = m_{l-1,l} = m_{l1} = 1$ . In general case make use of the fact that any principal submatrix of  $A$  is a Cartan matrix.

54. Notice that otherwise there can be found a subdiagram of one of the types listed in the statement. Next, make use of Proposition 1 and properties (D1), (D5), (D6).
55. Notice that any diagram with two or more singularities contains one of the subdiagrams listed in the problem.
56. Make use of Corollary of Theorem 11 and the recurrent formula  $\delta(L_l) = 2\delta(L_{l-1}) - \delta(L_{l-2})$ , where  $L_l = E_l, F_l$  or  $F_l^\vee$ .
57. Prove that the corresponding matrices are not invertible.
58. Make use of Problem 56, 57 and properties (D1), (D5), (D6).
60. The system  $\Delta_0$  is reduced thanks to Problem 2.
61. In  $\Delta_0$ , select a base  $\Pi$ . Theorem 7 implies the existence of  $\alpha \in \Pi$  such that  $2\alpha \in \Delta$ . If  $\beta \in \Pi, \beta \neq \alpha$  and  $(\alpha, \beta) \neq 0$  then  $\langle \beta | \alpha \rangle = 2\langle \beta | 2\alpha \rangle = -2$  so that  $|\beta|^2 = 2|\alpha|^2$ . Theorem 13 implies that the type of  $\Delta_0$  is  $B_l$ .
62. Make use of Problem 61 and prove that  $\Delta \setminus \Delta_0$  is the set of all doubled short roots from  $\Delta_0$ .
63. Notice that the invariant factors of a matrix with integer entries are preserved under transposition.
65. Follows from (6).
66. First prove that  $P = (Q^\vee)^*$ . The fact that fundamental groups are isomorphic follows from Problem 63.
67. Make use of Problems 1.34 and 66.

### § 3. Existence and Uniqueness Theorems

In this section we will prove that any Cartan matrix (see 2.6) corresponds to the root system of a unique (up to an isomorphism) semisimple complex Lie algebra. After that we will study connected complex semisimple Lie groups globally. In particular, we will prove that all these groups are algebraic and we will classify them up to an isomorphism. We will also describe irreducible finite-dimensional linear representations of connected complex semisimple Lie groups. Everywhere except  $1^\circ$  the ground field is  $\mathbb{C}$ .

**1°. Free Lie Algebras, Generators and Defining Relations.** Let  $\mathfrak{a}$  be a Lie algebra over  $k$ ,  $X \subset \mathfrak{a}$  a subset. Denote by  $\mathfrak{b}$  the intersection of all subalgebras of  $\mathfrak{a}$  containing  $X$ . Clearly,  $\mathfrak{b}$  is the smallest subalgebra of  $\mathfrak{a}$  containing  $X$ ; it is called the *subalgebra of  $\mathfrak{a}$  generated by  $X$* . In particular, if  $\mathfrak{b} = \mathfrak{a}$  then one says that  $X$  is a *system of generators* of  $\mathfrak{a}$ ; this means that there is no proper subalgebra of  $\mathfrak{a}$  containing  $X$ . In what follows we will consider the case when  $X = \{x_1, \dots, x_n\}$  is finite. A Lie algebra admitting a finite system of generators is called *finitely generated*. For instance, any finite-dimensional Lie algebra is finitely generated.

**Problem 1.** A set  $x_1, \dots, x_n$  is a system of generators of a Lie algebra  $\mathfrak{a}$  if and only if each element of  $\mathfrak{a}$  is a linear combination of elements of the form

$$[\dots, [[x_{i_1}, x_{i_2}], x_{i_3}], \dots], x_{i_m} \quad (1 \leq i_1, \dots, i_m \leq n). \quad (1)$$

Let us now construct an important example of a Lie algebra with a given system of generators  $X = \{x_1, \dots, x_n\}$ . Define by induction non-associative words in the alphabet  $X$  in the following way: a word of length 1 is any element  $x_i \in X$ ; a word of length  $m > 1$  is a pair  $(y, z)$ , where  $y$  and  $z$  are words of length  $p$  and  $q$  respectively for  $p \geq 1, q \geq 1, p + q = m$ . Thus the set  $X_1$  of words of length 1 coincides with  $X$  and the set  $X_m$  of words of length  $m > 1$  is defined by induction as follows:

$$X_m = \coprod_{p+q=m} X_p \times X_q.$$

In the set  $M_X = \coprod_{m \geq 1} X_m$  there is a binary algebraic operation assigning to each  $y \in X_p$  and  $z \in X_q$  the word  $(y, z) \in X_{p+q}$ . Let us consider the corresponding algebra  $k[M_X]$  over the field  $k$ . This is the vector space over  $k$  consisting of elements of the form  $\sum_{z \in M_X} c_z z$ , where  $c_z \in k, c_z = 0$  for all  $z$  except a finite number, and endowed with a multiplication which extends by linearity the operation in  $M_X$ . The algebra  $k[M_X]$  is called the *free algebra over  $k$  generated by the set  $X$* . The set  $M_X$  is its basis over  $k$ .

**Problem 2.** Let  $A$  be any algebra over  $k$  with fixed elements  $a_1, \dots, a_n$ . Then there exists a unique algebra homomorphism  $\varphi: k[M_X] \rightarrow A$ , such that  $\varphi(x_i) = a_i$  for any  $i = 1, \dots, n$ .

Denote by  $I$  the two-sided ideal of  $k[M_X]$ , generated by elements of the form  $x_i x_i$  and  $(x_i x_j) x_k + (x_j x_k) x_i + (x_k x_i) x_j$ , where  $1 \leq i, j, k \leq n$ . The algebra

$$l(X) = l(x_1, \dots, x_n) = k[M_X]/I$$

is, clearly, a Lie algebra. It is called the *free Lie algebra generated by  $X$  (over  $k$ )*.

**Problem 3.** Let  $\mathfrak{a}$  be any Lie algebra over  $k$ , with fixed elements  $a_1, \dots, a_n$ . Then there exists a unique Lie algebras homomorphism  $\varphi: l(x_1, \dots, x_n) \rightarrow \mathfrak{a}$ , such that  $\varphi(x_i) = a_i$  for any  $i = 1, \dots, n$ . Every finitely generated Lie algebra is isomorphic to a quotient of a (finitely generated) free Lie algebra.

Let  $\mathfrak{a}$  be again an arbitrary Lie algebra over  $k$  and  $X$  a subset of  $\mathfrak{a}$ . Consider the intersection  $\mathfrak{i}$  of all ideals of  $\mathfrak{a}$  containing  $X$ ; this is the smallest ideal of  $\mathfrak{a}$  containing  $X$ . We say that  $\mathfrak{i}$  is *generated* by  $X$ .

In particular, let  $(f_i)_{i \in I}$  be a family of elements of a free Lie algebra  $l(x_1, \dots, x_n)$  and  $\mathfrak{i}$  the ideal of  $l(x_1, \dots, x_n)$  generated by this family. The quotient algebra  $l(x_1, \dots, x_n)/\mathfrak{i}$  is called the Lie algebra with *generators*  $y_j = x_j + \mathfrak{i}$  ( $j = 1, \dots, n$ ) and *defining relations*  $f_i(y_1, \dots, y_n) = 0$  ( $i \in I$ ).

**2°. Uniqueness Theorems.** Let  $\mathfrak{g}$  be a complex semisimple Lie algebra,  $\mathfrak{t}$  its maximal diagonalizable subalgebra,  $\Pi = \{\alpha_1, \dots, \alpha_l\}$  a system of simple roots of  $\mathfrak{g}$  with respect to  $\mathfrak{t}$ . Under the notation of 1.4° and 1.6° set

$$h_i = h_{\alpha_i}, e_i = e_{\alpha_i}, f_i = e_{-\alpha_i} \quad (i = 1, \dots, l).$$

Let  $A = (a_{ij})$  be the matrix of  $\Pi$ ; we will call it the *Cartan matrix* of  $\mathfrak{g}$ .

**Problem 4.** The elements  $h_i, e_i, f_i$  ( $i = 1, \dots, l$ ) form the system of generators of  $\mathfrak{g}$  and satisfy

$$\begin{aligned} [h_i, h_j] &= 0, \\ [h_i, e_j] - a_{ji}e_j &= 0, \quad [h_i, f_j] + a_{ji}f_j = 0, \\ [e_i, f_i] - h_i &= 0, \quad [e_i, f_j] = 0 \quad \text{for } i \neq j. \end{aligned} \tag{2}$$

The system  $\{h_i, e_i, f_i: i = 1, \dots, l\}$  is called the *canonical system of generators* of  $\mathfrak{g}$  associated with  $\mathfrak{t}$  and  $\Pi$ .

Now denote by  $\hat{\mathfrak{g}} = \hat{\mathfrak{g}}(A)$  the Lie algebra with generators  $\hat{h}_i, \hat{e}_i, \hat{f}_i$  ( $i = 1, \dots, l$ ) and defining relations obtained from (2) by replacing  $h_i, e_i, f_i$  by  $\hat{h}_i, \hat{e}_i, \hat{f}_i$ , respectively. Problems 3 and 4 imply that there exists an epimorphism  $\pi: \hat{\mathfrak{g}} \rightarrow \mathfrak{g}$  such that

$$\pi(\hat{h}_i) = h_i, \quad \pi(\hat{e}_i) = e_i, \quad \pi(\hat{f}_i) = f_i. \tag{3}$$

In particular, the elements  $\hat{h}_1, \dots, \hat{h}_l$  are linearly independent. The subspace  $\hat{\mathfrak{t}}$  generated by them is a commutative subalgebra of  $\hat{\mathfrak{g}}$ .

Denote by  $\hat{\mathfrak{n}}^+(\hat{\mathfrak{n}}^-)$  the subalgebra of  $\hat{\mathfrak{g}}$  generated by  $\hat{e}_1, \dots, \hat{e}_l$  (resp.  $\hat{f}_1, \dots, \hat{f}_l$ ).

**Problem 5.**  $\hat{\mathfrak{g}} = \mathfrak{t} + \hat{\mathfrak{n}}^+ + \hat{\mathfrak{n}}^-$ .

For any  $\alpha \in \hat{\mathfrak{t}}^*$  set

$$\hat{\mathfrak{g}}_\alpha = \{x \in \hat{\mathfrak{g}}: [h, x] = \alpha(h)x \text{ for all } h \in \hat{\mathfrak{t}}\} \tag{4}$$

**Problem 6.**  $\hat{\mathfrak{g}} = \bigoplus_\alpha \hat{\mathfrak{g}}_\alpha, \hat{\mathfrak{g}}_0 = \hat{\mathfrak{t}}$ .

**Problem 7.** Any ideal of  $\hat{\mathfrak{g}}$  is the sum of its intersections with the subspaces  $\hat{\mathfrak{g}}_\alpha$ .

**Problem 8.** Among the ideals of  $\hat{\mathfrak{g}}$  that do not contain any  $\hat{h}_i$ , there exists the largest ideal  $\mathfrak{m}$  and  $\mathfrak{m} = \mathfrak{m}^+ \oplus \mathfrak{m}^-$ , where  $\mathfrak{m}^\pm = \mathfrak{m} \cap \hat{\mathfrak{n}}^\pm$  are ideals of  $\hat{\mathfrak{g}}$ .

**Problem 9.**  $\text{Ker } \pi = \mathfrak{m}$ .

Therefore  $\mathfrak{g} \simeq \hat{\mathfrak{g}}/\mathfrak{m}$ . Since  $\mathfrak{m}$  is determined uniquely we have proved the following

**Theorem 1** (The first uniqueness theorem). *A semisimple Lie algebra is determined uniquely up to an isomorphism by its Cartan matrix (or Dynkin diagram). More precisely, if  $\mathfrak{g}$  and  $\tilde{\mathfrak{g}}$  are semisimple Lie algebras with canonical generators  $\{h_i, e_i, f_i (1 \leq i \leq l)\}$  and  $\{\tilde{h}_i, \tilde{e}_i, \tilde{f}_i (1 \leq i \leq l)\}$  respectively and equal Cartan matrices then there exists a (unique) isomorphism  $\varphi: \mathfrak{g} \rightarrow \tilde{\mathfrak{g}}$  such that  $\varphi(h_i) = \tilde{h}_i$ ,  $\varphi(e_i) = \tilde{e}_i$ ,  $\varphi(f_i) = \tilde{f}_i$ .*

Now let  $\rho: \mathfrak{g} \rightarrow \mathfrak{gl}(V)$  be a finite-dimensional linear representation,  $\Phi_\rho$  its weights system. Each weight  $\lambda \in P$  and, in particular, each weight  $\lambda \in \Phi_\rho$  is completely determined by the integers  $\lambda(h_i) = \langle \lambda | \alpha_i \rangle$  ( $i = 1, \dots, l$ ) which are its coordinates in the basis of fundamental weights  $\pi_1, \dots, \pi_l$  (see 2.8°).

The numbers  $\lambda(h_i)$  are called the *numerical labels* of  $\lambda$ .

Let  $V = \bigoplus_{\lambda \in \Phi_\rho} V_\lambda$  be the weight decomposition. A weight vector  $v \in V_\lambda$  is called a *highest vector* if

$$\rho(e_i)v = 0 \quad \text{for } i = 1, \dots, l. \quad (5)$$

The corresponding weight  $\lambda \in \Phi_\rho$  is called a *highest weight* of  $\rho$ .

*Example.* If  $\rho = \text{ad}$  for a simple Lie algebra  $\mathfrak{g}$  then the root vector  $e_\delta$  corresponding to the highest root (see 2.5°) is a highest vector and the highest root  $\delta$  is a highest weight of the representation.

**Problem 10.** For any weight  $\lambda \in \Phi_\rho$  there exist simple roots  $\alpha_{i_1}, \dots, \alpha_{i_k}$  such that  $\lambda + \alpha_{i_1} + \dots + \alpha_{i_k}$  is a highest weight. In particular, a highest weight exists for any finite-dimensional  $\rho$ .

Fix a highest weight  $\lambda \in \Phi_\rho$  and a highest vector  $v_\lambda \in V_\lambda$ . Denote by  $\lambda_i$  the numerical labels  $\lambda(h_i)$  of the highest weight. Consider the vectors

$$v_{i_1 \dots i_k} = \rho(f_{i_1}) \dots \rho(f_{i_k})v_\lambda \quad (1 \leq i_1, \dots, i_k \leq l), \quad v_\emptyset = v_\lambda. \quad (6)$$

Clearly,  $v_{i_1 \dots i_k} \in V_{\lambda - \alpha_{i_1} - \dots - \alpha_{i_k}}$  and

$$\begin{aligned} \rho(h_i)v_\emptyset &= \lambda_i v_\emptyset, \\ \rho(h_i)v_{i_1 \dots i_k} &= (\lambda_i - a_{i_1 i} - \dots - a_{i_k i})v_{i_1 \dots i_k}, \\ \rho(f_i)v_{i_1 \dots i_k} &= v_{i_1 \dots i_k}, \\ \rho(e_i)v_\emptyset &= 0, \\ \rho(e_i)v_{i_1 \dots i_k} &= (\delta_{ii_1} \rho(h_i) + \rho(f_{i_1})\rho(e_i))v_{i_2 \dots i_k}. \end{aligned} \quad (7)$$

These relations imply that the subspace of  $V$  spanned by  $v_{i_1 \dots i_k}, v_\emptyset$  is  $\rho(\mathfrak{g})$ -invariant.

An element  $\lambda \in \mathfrak{t}(\mathbb{R})^*$  is called *dominant* if  $(\lambda, \alpha_i) \geq 0$  ( $i = 1, \dots, l$ ). This means that  $\lambda$  belongs to the closure of the Weyl chamber  $C^\vee$  corresponding to the base  $\alpha_1^\vee, \dots, \alpha_l^\vee$  of  $A_{\mathfrak{g}}^\vee$ .

**Problem 11.** Any highest weight  $\lambda$  is dominant, i.e.  $(\lambda, \alpha_i) \geq 0$ .

Now suppose that  $\rho$  is irreducible. Clearly, in this case  $v_{i_1 \dots i_k}$  for all  $k$  and  $v_\emptyset$  generate  $V$ .

**Problem 12.** If  $\rho$  is irreducible and  $\lambda$  is its highest weight then  $\dim V_\lambda = 1$ . Any other weight  $\mu \in \Phi_\rho$  is of the form  $\mu = \lambda - \alpha_{i_1} - \dots - \alpha_{i_k}$ , where  $\alpha_{i_j} \in \Pi$ . The representation  $\rho$  has a unique highest weight.

Now we wish to prove that an irreducible linear representation  $\rho$  is determined uniquely up to an equivalence by its highest weight. For this we will make use of the following construction.

Consider a vector space  $\hat{V}$  over  $\mathbb{C}$  with basis  $\{\hat{v}_\emptyset, \hat{v}_{i_1 \dots i_k} : 1 \leq i_1, \dots, i_k \leq l, k \geq 1\}$ . Define a linear representation  $\hat{\rho} = \hat{\rho}_\lambda$  of the above Lie algebra  $\hat{\mathfrak{g}}$  in  $\hat{V}$  by determining it on generators by formulas (7) with  $h_i, e_i, f_i, v_{i_1 \dots i_k}, v_\emptyset$  and  $\rho$  replaced by  $\hat{h}_i, \hat{e}_i, \hat{f}_i, \hat{v}_{i_1 \dots i_k}, v_\emptyset$  and  $\hat{\rho}$  respectively. (The latter of these formulas should be considered as a recurrent definition of  $\hat{\rho}(\hat{e}_i)$ ).

**Problem 13.** Prove the existence of  $\hat{\rho}_\lambda$ .

For an arbitrary  $\lambda \in \hat{\mathfrak{t}}^*$  set

$$\hat{V}_\lambda = \{v \in \hat{V} : \hat{\rho}(h)v = \lambda(h)v \text{ for all } h \in \hat{\mathfrak{t}}\}. \tag{8}$$

Clearly,

$$\hat{V} = \bigoplus_{\lambda \in \hat{\mathfrak{t}}^*} \hat{V}_\lambda \tag{9}$$

**Problem 14.** Among the subspaces of  $\hat{V}$  invariant with respect to  $\hat{\rho}(\hat{\mathfrak{g}})$  and not coinciding with  $\hat{V}$  there exists the largest subspace  $M^\lambda$ .

**Problem 15.** There exists a unique linear map  $p: \hat{V} \rightarrow V$  with the following properties:

- a)  $p(\hat{v}_\emptyset) = v_\emptyset$ ;
- b) The diagram

$$\begin{array}{ccc} \hat{V} & \xrightarrow{\hat{\rho}(x)} & \hat{V} \\ p \downarrow & & \downarrow p \\ V & \xrightarrow{\rho(\pi(x))} & V \end{array}$$

commutes for any  $x \in \hat{\mathfrak{g}}$  and  $p(\hat{V}) = V$ .

**Problem 16.**  $\text{Ker } p = M^{(A)}$ .

**Problem 17.** The ideal  $\mathfrak{m}$  is contained in the kernel of the induced representation of  $\hat{\mathfrak{g}}$  in  $\hat{V}/M^{(A)}$ .

Thus  $\hat{\rho}$  uniquely determines a linear representation of the Lie algebra  $\hat{\mathfrak{g}}/\mathfrak{m} \cong \mathfrak{g}$  in  $\hat{V}/M^{(A)}$ . This representation is completely determined by  $A$ , and the statement b) of Problem 15 implies that it is equivalent to  $\rho$  if we identify  $\hat{\mathfrak{g}}/\mathfrak{m}$  and  $\mathfrak{g}$  with respect to the above isomorphism. Therefore the following theorem holds.

**Theorem 2** (The second uniqueness theorem). *An irreducible finite-dimensional linear representation of a semisimple Lie algebra is determined uniquely up to an isomorphism by its highest weight.*

In what follows we will often make use of the following method of describing irreducible linear representations of a semisimple Lie algebra  $\mathfrak{g}$ : on the Dynkin diagram of  $\mathfrak{g}$  mark the numerical labels of the representation above the corresponding vertices. By Theorem 2 the obtained diagram, called the *diagram of this representation*, determines it uniquely.

**3°. Existence Theorems.** Let  $A = (a_{ij})$  be an arbitrary  $l \times l$  matrix over  $\mathbb{C}$  and  $\Lambda = (\Lambda_1, \dots, \Lambda_l)$  an arbitrary set of  $l$  complex numbers. Exactly as in 2° we can construct the Lie algebra  $\hat{\mathfrak{g}} = \hat{\mathfrak{g}}(A)$ , the vector space  $\hat{V}$  and the linear representation  $\hat{\rho} = \hat{\rho}_A: \hat{\mathfrak{g}} \rightarrow \text{gl}(\hat{V})$  (it does not matter here whether  $A$  is a Cartan matrix and whether  $\Lambda_i$  are nonnegative or integer).

Clearly, the statements of Problems 5, 7, 13, 14 and formulas (5) and (9) remain true. The algebras  $\hat{\mathfrak{t}}$ ,  $\hat{\mathfrak{n}}^+$  and  $\hat{\mathfrak{n}}^-$  are defined as in 2° but the linear independence of the elements  $\hat{h}_1, \dots, \hat{h}_l$  has to be proved.

**Problem 18.** The elements  $\hat{h}_1, \dots, \hat{h}_l$  are linearly independent.

This implies that if  $A$  is invertible then the statements of Problems 6 and 8 remain true.

In what follows let  $A$  be invertible. Construct the quotient algebra  $\mathfrak{g} = \mathfrak{g}(A) = \hat{\mathfrak{g}}/\mathfrak{m}$  and the quotient space  $V = V(A) = \hat{V}/M^{(A)}$ , where  $\mathfrak{m}$  and  $M^{(A)}$  are defined as in 2°. Denote by  $\pi: \hat{\mathfrak{g}} \rightarrow \mathfrak{g}$  and  $p: \hat{V} \rightarrow V$  the natural maps. Set

$$\begin{aligned} h_i &= \pi(\hat{h}_i), & e_i &= \pi(\hat{e}_i), & f_i &= \pi(\hat{f}_i), & \mathfrak{t} &= \pi(\hat{\mathfrak{t}}), \\ \mathfrak{n}^\pm &= \pi(\hat{\mathfrak{n}}^\pm), & v_\emptyset &= p(\hat{v}_\emptyset), & v_{i_1 \dots i_k} &= p(\hat{v}_{i_1 \dots i_k}). \end{aligned}$$

Finally, denote by  $\rho'$  the linear representation of  $\hat{\mathfrak{g}}$  in  $V$  induced by  $\hat{\rho}$ . By construction  $\rho'$  is irreducible.

Let us decompose  $V$  into weight subspaces with respect to  $\rho'(\hat{\mathfrak{t}})$ . Namely, for any  $\lambda \in \hat{\mathfrak{t}}^*$  set

$$V_\lambda = \{v \in V: \rho'(h)v = \lambda(h)v \text{ for all } h \in \hat{\mathfrak{t}}\}.$$

Clearly,  $V_\lambda = p(\hat{V}_\lambda)$ . It follows from (9) that

$$V = \bigoplus_{\lambda \in \Omega} V_{\lambda},$$

where  $\Omega = \{\lambda \in \hat{t}^*: V_{\lambda} \neq 0\}$ .

On  $\hat{t}$ , define the linear functions  $\alpha_1, \dots, \alpha_l$  and  $A$  setting

$$\alpha_i(\hat{h}_j) = a_{ij}, \quad A(\hat{h}_i) = A_i. \quad (10)$$

Clearly,  $v_{\emptyset} \in V_{\lambda}$ .

**Problem 19.** We have  $\dim V_{\lambda} = 1$ . Any element  $\lambda \in \Omega$  presents in the form  $\lambda = A - \alpha_{i_1} - \dots - \alpha_{i_k}$ . If  $V_{\lambda}$  contains a nonzero element annihilated by all  $\rho'(\hat{e}_i)$  then  $\lambda = A$  (cf. Problem 12).

**Problem 20.**  $\dim V_{\lambda} < \infty$  for all  $\lambda \in \Omega$ .

**Problem 21.**  $\rho'(m) = 0$ .

This shows that  $\rho'$  determines an irreducible linear representation  $\rho = \rho(A): \mathfrak{g} \rightarrow \mathfrak{gl}(V)$ .

**Problem 22.** Any nonzero element of  $\mathfrak{g}$  contains at least one of the elements  $h_i$ .

**Problem 23.** If  $x \in \mathfrak{n}^-$  and  $[e_i, x] = 0$  ( $i = 1, \dots, l$ ) then  $x = 0$ . Similarly, if  $y \in \mathfrak{n}^+$  and  $[f_i, y] = 0$  ( $i = 1, \dots, l$ ) then  $y = 0$ .

Suppose now that  $A$  is a Cartan matrix and the numbers  $A_i$  are nonnegative integers. Our aim is to prove the following statements:

- 1)  $V$  and  $\mathfrak{g}$  are finite-dimensional;
- 2)  $\mathfrak{g}$  is semisimple and its Cartan matrix coincides with  $A$ ;
- 3) The numerical labels of the highest weight of  $\rho(A)$  are  $A_i$ .

These statements obviously imply the following theorems.

**Theorem 3** (The first existence theorem.) *Any Cartan matrix is the Cartan matrix of a semisimple Lie algebra.*

**Theorem 4** (The second existence theorem.) *For any semisimple Lie algebra  $\mathfrak{g}$  and any dominant weight  $\lambda \in \rho$  there exists an irreducible finite-dimensional linear representation  $\rho(\lambda)$  of  $\mathfrak{g}$  with highest weight  $\lambda$ .*

Theorems 3 and 1 imply in particular that each of the exceptional Dynkin diagrams  $E_6, E_7, E_8, F_4, G_2$  (see 2.7°) is a Dynkin diagram of a uniquely determined noncommutative simple Lie algebra. These Lie algebras are called *exceptional* and are denoted in the same way as their Dynkin diagrams. Their dimensions are listed in Table 1. The root systems of these Lie algebras are the root systems corresponding to the exceptional Dynkin diagrams whose existence has been established by an explicit construction in §2.

First of all let us prove that  $V$  is finite-dimensional. Problem 20 implies that it suffices to prove the finiteness of  $\Omega$ .

In  $\hat{t}^*$ , consider the subgroup

$$L = \{\gamma \in \hat{t}^*: \gamma(\hat{h}_i) \in \mathbb{Z} (i = 1, \dots, l)\}.$$

Clearly,  $L$  is a lattice in its real linear span  $\mathbf{E}$ . Furthermore, the elements  $\alpha_1, \dots, \alpha_l$  and  $A$  defined by formula (10) are contained in  $L$ .

**Problem 24.**  $\Omega \subset L$ .

Since  $A$  is invertible,  $\alpha_1, \dots, \alpha_l$  constitute a basis of  $\mathbf{E}$  over  $\mathbb{R}$ . Theorem 2.9 implies that there exists a positive definite scalar product  $\langle \cdot, \cdot \rangle$  on  $\mathbf{E}$  such that  $\langle \alpha_i | \alpha_j \rangle = a_{ij}$  for all  $i, j$ . Let  $r_i$  be the orthogonal reflection in  $\mathbf{E}$  with respect to the hyperplane orthogonal to  $\alpha_i$ . Problem 2.1 implies that  $r_i(L) = L$ . Therefore the group  $W$  generated by  $r_i$  ( $i = 1, \dots, l$ ) is finite (cf. Problem 2.34). Now let us prove that  $\Omega$  is  $W$ -invariant.

**Problem 25.**  $[\hat{e}_k, (\text{ad } \hat{f}_j)^{-a_{ij}+1} \hat{f}_i] = [\hat{f}_k, (\text{ad } \hat{e}_j)^{-a_{ji}+1} \hat{e}_i] = 0$  for any  $i \neq j$  and any  $k$ .

**Problem 26.**  $(\text{ad } f_j)^{-a_{ij}+1} f_i = (\text{ad } e_j)^{-a_{ji}+1} e_i = 0$  for any  $i \neq j$ .

Problem 26 implies that

$$\rho((\text{ad } f_j)^{-a_{ij}+1} f_i) = \text{ad } \rho(f_j)^{-a_{ij}+1} \rho(f_i) = 0 \quad (i \neq j). \quad (11)$$

**Problem 27.** Let  $p$  and  $q$  be two elements of an associative algebra such that  $(\text{ad } p)^l q = 0$ . Then any product of them containing  $m$  factors equal to  $p$  and  $n$  factors equal to  $q$  presents as a linear combination of products of the form  $p^{l_1} q p^{l_2} q \dots p^{l_n} q p^{l_0}$  where  $l_i \geq 0$ ,  $\sum_{0 \leq i \leq n} l_i = m$ ,  $l_i < l$  for  $i = 1, \dots, n$ .

A linear operator  $p$  is *locally nilpotent* if for any vector  $v$  there exists  $m$  such that  $p^m v = 0$ . (If  $p$  acts on a finite-dimensional space then  $p$  is nilpotent.)

**Problem 28.**  $\rho(f_i)^{A_i+1} v_\emptyset = 0$ .

**Problem 29.**  $\rho(f_i)$  and  $\rho(e_i)$  are locally nilpotent in  $V$ .

Denote by  $\mathfrak{g}^{(i)}$  the subspace of  $\mathfrak{g}$  spanned by  $h_i, e_i, f_i$ . Clearly, this is a subalgebra isomorphic to  $\mathfrak{sl}_2(\mathbb{C})$ .

**Problem 30.** The space  $V$  splits into the direct sum of finite-dimensional subspaces invariant with respect to  $\rho(\mathfrak{g}^{(i)})$  (for a fixed  $i$ ).

Let  $\rho_i$  be a linear representation of  $\mathfrak{sl}_2(\mathbb{C})$  in  $V$  which sends the matrices  $\mathbf{h}, \mathbf{e}, \mathbf{f}$  in  $\rho(h_i), \rho(e_i), \rho(f_i)$ , respectively. By Problem 30 there exists a linear representation  $R_i: \text{SL}_i(\mathbb{C}) \rightarrow \text{GL}(V)$  preserving the finite-dimensional subspaces appearing in this problem and such that  $dR_i = \rho_i$  in each of these subspaces. Set

$$w_i = R_i \left( \begin{pmatrix} 0 & 1 \\ -1 & 0 \end{pmatrix} \right).$$

Let us extend  $r_i$  onto  $\hat{\mathfrak{t}}^*$  by linearity and denote the dual reflection in  $\hat{\mathfrak{t}}$  also by  $r_i$ . Since  $\pi: \hat{\mathfrak{t}} \rightarrow \mathfrak{t}$  (by the definition of  $\mathfrak{m}$ ) is an isomorphism, we will identify  $\hat{\mathfrak{t}}$  and  $\mathfrak{t}$  with the help of  $\pi$ .

**Problem 31.**  $w_i \rho(h) w_i^{-1} = \rho(r_i(h))$  ( $h \in \mathfrak{t} = \hat{\mathfrak{t}}$ ).

**Problem 32.** We have  $V_{r_i(\lambda)} = w_i V_\lambda$  for any  $\lambda \in \mathfrak{t}^*$ ; in particular,  $r_i(\Omega) = \Omega$ .

**Problem 33.** For any  $\gamma \in E$  there exists  $w \in W$  such that  $(w(\gamma), \alpha_i) \geq 0$  for all  $i = 1, \dots, l$ .

**Problem 34.** We have  $(\lambda, \lambda) \leq (A, A)$  for any  $\lambda \in \Omega$ .

Therefore,  $\Omega$  is a bounded subset of  $L$  and hence it is finite. We have proved that  $V$  is finite-dimensional. Now let us go over to studying  $\mathfrak{g}$ .

For  $\alpha \in \mathfrak{t}^*$  set

$$\mathfrak{g}_\alpha = \{x \in \mathfrak{g}: [h, x] = \alpha(h)x \text{ for all } h \in \mathfrak{t}\}.$$

Clearly,

$$\mathfrak{g} = \mathfrak{t} \oplus \bigoplus_{\alpha \neq 0} \mathfrak{g}_\alpha.$$

**Problem 35.** If  $A_i \neq 0$  for all  $i$  then  $\text{Ker } \rho = 0$ .

**Problem 36.** The Lie algebra  $\mathfrak{g}$  is finite-dimensional and semisimple.

**Problem 37.** The subalgebra  $\mathfrak{t}$  is a maximal diagonalizable subalgebra of  $\mathfrak{g}$ .

**Problem 38.** The linear functions  $\alpha_1, \dots, \alpha_l$  on  $\mathfrak{t} = \hat{\mathfrak{t}}$  form a system of simple roots of  $\mathfrak{g}$  with respect to  $\mathfrak{t}$  and  $\{h_i, e_i, f_i (1 \leq i \leq l)\}$  is a canonical system of generators.

**Problem 39.** The Cartan matrix of  $\{\alpha_1, \dots, \alpha_l\}$  coincides with the Cartan matrix of  $\mathfrak{g}$ .

**Problem 40.** The weight  $A$  is the highest weight of the linear representation  $\rho$ .

*Example.* Let  $\mathfrak{g} = \mathfrak{sl}_2(\mathbb{C})$ . By theorems 4 and 2 there exists a unique up to an equivalence irreducible representation  $\rho_k$  of  $\mathfrak{g}$  with the diagram

$$\begin{array}{c} k \\ \circ \end{array} \tag{12}$$

where  $k$  is an arbitrary nonnegative integer. Let  $V$  be the space of this representation. The highest weight of  $\rho_k$  is of the form  $A = k\alpha/2$  where  $\alpha$  is the positive root of  $\mathfrak{sl}_2(\mathbb{C})$ . By Problem 12 all the weights of  $\rho_k$  are of the form  $A - s\alpha = (k - 2s)\alpha/2$  where  $s$  is an integer. Since the system of weights  $\Phi_{\rho_k}$  is symmetric (Corollary of Theorem 1.5), we have  $0 \leq s \leq k$  so that

$$\Phi_{\rho_k} = \{p\alpha/2: p = k, k - 2, \dots, 2 - k, -k\}.$$

The weight basis consists of the vectors of the form  $v_{i_1 \dots i_k}$  determined by (6). Here it is clear that  $\dim V_\lambda = 1$  for all  $\lambda \in \Phi_{\rho_k}$  and that as the weight vectors we can take

$$v_{A-s\alpha} = \rho_k(f)^s v_A \quad (s = 0, 1, \dots, k),$$

where  $v_A$  is a highest vector. Therefore  $\dim V = k + 1$  and

$$\rho_k(e)v_{A-s\alpha} = s(k-s+1)v_{A-(s-1)\alpha} \quad (s = 1, \dots, k)$$

$$\rho_k(e)v_A = 0.$$

For  $k = 0$  we get the trivial one-dimensional representation, for  $k = 1$  the standard representation in  $\mathbb{C}^2$ , for  $k = 2$  the adjoint representation.

**4°.** **The Linearity of a Connected Complex Semisimple Lie Group.** Let  $G$  be a connected semisimple algebraic group over  $\mathbb{C}$ ,  $T$  its maximal torus,  $Q \subset P \subset \mathfrak{t}(\mathbb{R})^*$  the root and weight lattices of the root system  $\Delta_G$  (see 2.8°).

**Theorem 5.** *The group  $G$  is simply connected if and only if*

$$\mathcal{X}(T) = P. \quad (13)$$

First we prove the sufficiency of the condition (13) and then we apply it to prove Theorem 6. The latter proof will also imply the necessity of this condition.

Let  $\{\alpha_1, \dots, \alpha_l\}$  be a system of simple roots of  $G$  with respect to  $T$ ,  $G^{(k)} = G^{(\alpha_k)}$  the three-dimensional subgroup of  $G$  corresponding to  $\alpha_k$  (see 1.6°),  $T^{(k)}$  the maximal torus of  $G^{(k)}$  belonging to  $T$ .

**Problem 41.** Under condition (13) all groups  $G^{(k)}$  are simply connected.

**Problem 42.** Under the same condition  $T = T^{(1)} \times \dots \times T^{(l)}$ .

**Problem 43.** For any connected reductive algebraic group  $G$  the homomorphism  $i_*: \pi_1(T) \rightarrow \pi_1(G)$  generated by the embedding of the maximal torus  $i: T \rightarrow G$  is surjective.

Therefore it suffices to prove that (13) implies  $i_* = 0$ . To do this consider the diagram

$$\begin{array}{ccc} T = T^{(1)} \times \dots \times T^{(l)} & \xrightarrow{i} & G \\ & \searrow^{i^{(1)} \times \dots \times i^{(l)}} & \uparrow m \\ & & G^{(1)} \times \dots \times G^{(l)} \end{array}$$

where  $i^{(k)}: T^{(k)} \rightarrow G^{(k)}$  is an embedding and  $m(g_1, \dots, g_l) = g_1 \dots g_l$  (see Problem 42). Clearly, the diagram commutes, hence  $i_* = m_* (i_*^{(1)} \times \dots \times i_*^{(l)})$ , but  $i_*^{(k)} = 0$  by Problem 42. Therefore  $i_* = 0$  and the sufficiency of (13) is proved.

**Theorem 6.** *Any connected semisimple Lie group admits a faithful finite-dimensional linear representation.*

**Corollary.** *Any connected semisimple Lie group admits a unique structure of an algebraic group.*

**Problem 44.** Reduce the proof of the theorem to the case of a simply connected group.

**Problem 45.** For any semisimple Lie algebra  $\mathfrak{g}$  there exists a linear representation  $\rho$  whose weights generate the weight lattice  $P$  of the root system  $\Delta_{\mathfrak{g}}$ . Such a representation  $\rho$  is always faithful.

Now we will prove Theorem 6 for a simply connected semisimple group  $G$ . Let  $\mathfrak{g}$  be the tangent algebra of  $G$ . By Theorem 1.2.6 there exists a linear representation  $R$  of  $G$  such that  $dR = \rho$  is the representation of  $\mathfrak{g}$  satisfying the condition of Problem 45. Let us prove that  $R$  is faithful. Clearly,  $R(G)$  is a connected algebraic group with tangent algebra  $\rho(\mathfrak{g}) \simeq \mathfrak{g}$ . If we identify the maximal diagonalizable subalgebra  $\mathfrak{t}$  of  $\mathfrak{g}$  with  $\rho(\mathfrak{t})$  with the help of  $\rho$ , the weights of  $\rho$  are identified with the weights of the identity representation of  $R(G)$  which are the differentials of characters of the maximal torus of  $R(G)$ . Therefore  $R(G)$  satisfies the condition (13) and is, as we have already proved, simply connected. Thus the covering  $R: G \rightarrow R(G)$  is bijective. Theorem 6 is proved.  $\square$

If  $G$  is a simply connected semisimple algebraic group then Problem 45 implies the existence of a representation  $R$  of  $G$  whose weights generate  $P$ . Therefore, (13) holds thereby completing the proof of Theorem 5.  $\square$

**5°. The Center and the Fundamental Group.** Let  $T$  be an algebraic torus,  $\mathfrak{t}$  its tangent algebra. We will now establish a one-to-one correspondence between the finite subgroups of  $T$  and the lattices in  $\mathfrak{t}(\mathbb{R})$  containing  $\mathfrak{t}(\mathbb{Z})$ . To this end consider the homomorphism  $\mathcal{E}: \mathfrak{t} \rightarrow T$  defined by the formula

$$\mathcal{E}(x) = \exp(2\pi ix). \tag{14}$$

**Problem 46.**  $\text{Ker } \mathcal{E} = \mathfrak{t}(\mathbb{Z})$ .

**Problem 47.** For any finite subgroup  $S \subset T$  its pre-image  $\mathcal{E}^{-1}(S)$  is a lattice in  $\mathfrak{t}(\mathbb{R})$ . The map  $S \mapsto \mathcal{E}^{-1}(S)$  establishes a bijective correspondence between finite subgroups of  $T$  and lattices in  $\mathfrak{t}(\mathbb{R})$  containing  $\mathfrak{t}(\mathbb{Z})$ . We also have

$$S \simeq \mathcal{E}^{-1}(S)/\mathfrak{t}(\mathbb{Z}).$$

Now apply these considerations to calculate the center and the fundamental group of a semisimple Lie group in terms of the lattice of characters of its maximal torus. Recall (see Theorem 2.6) that the center  $Z(G)$  of a connected semisimple Lie group  $G$  is contained in any its maximal torus  $T$ . Consider, as in 2.8°, the root and the weight lattices  $Q \subset P \subset \mathfrak{t}(\mathbb{R})^*$  and their dual lattices  $Q^\vee \subset P^\vee \subset \mathfrak{t}(\mathbb{R})$ .

**Theorem 7.** Let  $G$  be a connected semisimple Lie group,  $T$  its maximal torus. Then  $\mathcal{E}^{-1}(Z(G)) = P^\vee$  and

$$Z(G) \simeq P^\vee/\mathfrak{t}(\mathbb{Z}) \cong \mathcal{X}(T)/Q.$$

**Problem 48.** Prove this theorem.

**Corollary.** If  $G$  is a simply connected semisimple Lie group then  $Z(G) \simeq P/Q = \pi(\Delta_G)$ .

**Problem 49.** Let  $\tilde{G}, G$  be connected semisimple Lie groups and let a homomorphism  $p: \tilde{G} \rightarrow G$  be a covering. If  $\tilde{T} \subset \tilde{G}$  and  $T \subset G$  are maximal tori then  $p(\tilde{T})$  and  $p^{-1}(T)$  are maximal tori of  $G$  and  $\tilde{G}$  respectively. If  $T = p(\tilde{T})$ , we have the commutative diagram

$$\begin{array}{ccc} \tilde{T} & \xrightarrow{p} & T \\ \tilde{\mathcal{E}} \uparrow & & \uparrow \mathcal{E} \\ \mathfrak{t} & \xrightarrow{dp} & \mathfrak{t} \end{array} \quad (15)$$

where  $dp$  is an isomorphism and where  $\mathcal{E}$  and  $\tilde{\mathcal{E}}$  are defined by (14).

**Theorem 8.** Let  $p: \tilde{G} \rightarrow G$  be a simply connected covering of a semisimple Lie group  $G$ . Then  $\tilde{\mathcal{E}}^{-1}(\text{Ker } p) = \mathfrak{t}(\mathbb{Z})$  and

$$\pi_1(G) \simeq \mathfrak{t}(\mathbb{Z})/Q^\vee \simeq P(\mathcal{X}(T)).$$

**Problem 50.** Prove this theorem.

**6°. Classification of Connected Semisimple Lie Groups.** In this section we will prove the following two theorems.

**Theorem 9** (The global uniqueness theorem.) *A connected semisimple Lie group  $G$  is determined uniquely up to an isomorphism by its Dynkin diagram and the character lattice  $\mathcal{X}(T)$  of a maximal torus  $T \subset G$ . More precisely, if  $G_1, G_2$  are two connected semisimple Lie groups,  $T_i \subset G_i$  their maximal tori,  $\Pi_i$  the corresponding systems of simple roots then for any isomorphism  $\psi: \Pi_1 \rightarrow \Pi_2$  which maps  $\mathcal{X}(T_1)$  onto  $\mathcal{X}(T_2)$  there exists an isomorphism  $\Phi: G_1 \rightarrow G_2$  mapping  $T_1$  onto  $T_2$  and inducing  $\psi$ .*

**Theorem 10** (The global existence theorem). *Let  $\Delta \subset \mathbf{E}$  be a reduced root system,  $Q \subset P \subset \mathbf{E}$  its root and weight lattices. For any lattice  $L \subset \mathbf{E}$  such that  $Q \subset L \subset P$  there exist a connected semisimple Lie group  $G$ , its maximal torus  $T$  and a root system isomorphism  $\Delta_G \rightarrow \Delta$  mapping  $\mathcal{X}(T)$  into  $L$ .*

Proof of Theorem 9 is based on the following problem.

**Problem 51.** Let  $G_1, G_2$  be two connected semisimple Lie groups,  $T_i \subset G_i$  their maximal tori. For any isomorphism  $\varphi: \mathfrak{g}_1 \rightarrow \mathfrak{g}_2$  such that  $\varphi(\mathfrak{t}_1(\mathbb{Z})) = \mathfrak{t}_2(\mathbb{Z})$  there exists an isomorphism  $\Phi: G_1 \rightarrow G_2$  such that  $d\Phi = \varphi$ .

**Problem 52.** Prove Theorem 9.

To prove Theorem 10 consider a semisimple Lie algebra  $\mathfrak{g}$  whose Cartan matrix coincides with the Cartan matrix of  $\Delta$  (see Theorem 3). By Theorem 2.9 we may identify  $\Delta$  with the root system  $\Delta_{\mathfrak{g}}$  with respect to a maximal diagonalizable subalgebra  $\mathfrak{t}$ . Let  $\tilde{G}$  be a simply connected Lie group with the tangent algebra  $\mathfrak{g}$ ,  $\tilde{T} = \exp \mathfrak{t}$  a maximal torus and  $\tilde{\mathcal{E}}: \mathfrak{t} \rightarrow \tilde{T}$  the homomorphism defined by formula (14). Set  $N = \tilde{\mathcal{E}}(L^*)$ , where  $L^* \subset P^\vee$  is the dual lattice of  $L$ . By Theorem 7  $N \subset Z(\tilde{G})$ . The group  $G = \tilde{G}/N$  is the desired one. In fact,  $L^* = \tilde{\mathcal{E}}^{-1}(N)$  since  $Q^\vee = \text{Ker } \tilde{\mathcal{E}}$  by Theorem 5 and  $L^* \supset Q^\vee$ . Considering diagram (15), where  $T = \tilde{T}/N$  and  $p: \tilde{G} \rightarrow G$  is the natural homomorphism, we see that  $\mathfrak{t}(Z) = L^*$  and therefore  $\mathcal{X}(T) = L$ .

Notice that a lattice  $L$  such that  $Q \subset L \subset P$  is completely determined by the subgroup  $L/Q$  of the finite group  $P/Q = \pi(\Delta)$ . Therefore the classification of connected semisimple Lie groups can be given in terms of subgroups of  $\pi(\Delta)$ . (Notice that by Theorem 7 the group  $L/Q$  is isomorphic to the center of the semisimple Lie group  $G$  corresponding to  $L$ .) Let us give the corresponding formulation in terms of Cartan matrices.

Let  $A$  be an  $l \times l$  Cartan matrix. Then its rows generate a lattice  $Q_A$  in  $\mathbb{R}^l$  such that  $Q_A \subset \mathbb{Z}^l$ . Set  $\pi(A) = \mathbb{Z}^l/Q_A$ . By an *isomorphism* of Cartan matrices  $A_1$  and  $A_2$  we will mean a pair of identical permutations of rows and columns of  $A_1$  that transforms  $A_1$  to  $A_2$ . Any such isomorphism determines an isomorphism  $\pi(A_1) \rightarrow \pi(A_2)$ .

**Problem 53.** There is a bijection between the connected semisimple Lie groups  $G$  (considered up to an isomorphism) and the pairs  $(A, Z)$ , where  $A$  is a Cartan matrix and  $Z$  is a subgroup of  $\pi(A)$ , considered up to an isomorphism of Cartan matrices  $A$  that transform subgroups  $Z$  into each other. If a pair  $(A, Z)$  corresponds to  $G$  then  $A$  is the matrix of  $\mathfrak{g}$  and  $Z \cong Z(G)$ .

*Example 1.* Let  $\mathfrak{g}$  be a simple Lie algebra. Let us see what the classification of connected Lie groups  $G$  with the tangent algebra  $\mathfrak{g}$  looks like. If  $\mathfrak{g} \neq D_{2s}$ ,  $s \geq 2$ , then  $\pi(\Delta_{\mathfrak{g}})$  is a cyclic group. Therefore any of its subgroups is invariant under all the automorphisms of the group  $\pi(\Delta_{\mathfrak{g}})$ . Therefore in this case  $G$  is determined up to an isomorphism by  $\mathfrak{g}$  and the center  $Z(G)$  which may be isomorphic to an arbitrary subgroup of  $\pi(\Delta_{\mathfrak{g}})$ .

*Example 2.* Let  $\mathfrak{g} = D_{2s} = \mathfrak{so}_{4s}(\mathbb{C})$ ,  $s \geq 2$ . Then  $\pi(\Delta_{\mathfrak{g}}) \simeq \mathbb{Z}_2 \oplus \mathbb{Z}_2$ . Clearly, for  $n \geq 3$  the only nontrivial automorphism of the Dynkin diagram (or the Cartan matrix) permutes the summands of this direct sum. Therefore there exist exactly two nonisomorphic connected Lie groups  $G$  with the tangent algebra  $\mathfrak{so}_{4s}(\mathbb{C})$  ( $s \geq 3$ ) and the center  $Z(G) \simeq \mathbb{Z}_2$ . Furthermore, for  $\mathfrak{g} = D_4$  the automorphism group of the Dynkin diagram, isomorphic to  $S_3$ , acts as the automorphism group of the group  $\mathbb{Z}_2 \oplus \mathbb{Z}_2$ . Therefore, in this case there exists a unique connected Lie group with the given center.

**7°. Classification of Irreducible Representations.** Let  $G$  be a connected semisimple Lie group. To any finite-dimensional linear representation  $R: G \rightarrow GL(V)$  one can associate a representation  $\rho = dR: \mathfrak{g} \rightarrow \mathfrak{gl}(V)$  of the tangent Lie algebra

g. The weight system  $\Phi_R$  of  $R$  with respect to a maximal torus  $T \subset G$  coincides with the weight system  $\Phi_\rho$  with respect to the corresponding subalgebra  $\mathfrak{t}$  of  $\mathfrak{g}$ . The *highest vectors* and the *highest weights* of  $R$  are the highest vectors and the highest weights of  $\rho$ . If  $R$  is irreducible then so is  $\rho$  and Problem 12 implies that  $R$  possesses a unique highest weight  $\lambda \in \mathcal{X}(T)$ . By Problem 11  $\lambda$  is dominant. The *diagram of an irreducible linear representation  $R$*  is the diagram of  $\rho$ .

**Theorem 11.** *An irreducible finite-dimensional linear representation of a connected semisimple Lie group  $G$  is determined uniquely up to an equivalence by its highest weight. For any dominant character  $\lambda \in \mathcal{X}(T)$  there exists an irreducible finite-dimensional linear representation of  $G$  with highest weight  $\lambda$ .*

**Problem 54.** Prove this theorem.

*Example.* Since  $SL_2(\mathbb{C})$  is simply connected, it has a representation  $R_k$  with diagram (12) such that  $dR_k = \rho_k$  ( $k$  is any nonnegative integer). Clearly,  $R_k(-E) = E$  if and only if  $k$  is even. Therefore the irreducible representations of  $SO_3(\mathbb{C}) \simeq SL_2(\mathbb{C})/\{\pm E\}$  are determined by diagrams (12) with arbitrary even  $k \geq 0$ .

Now, introduce lowest weights which are sometimes more convenient than highest weights. Let  $R$  be a finite-dimensional linear representation of a connected semisimple Lie group in a space  $V$  and  $\rho = dR$  the corresponding tangent representation. A *lowest vector* of  $R$  (or  $\rho$ ) is a (nonzero) weight vector  $v \in V$  such that  $\rho(f_i)v = 0$  ( $i = 1, \dots, l$ ). The corresponding weight is called a *lowest weight*. For instance, the *lowest root* of a simple Lie algebra (see 2.5°) is the lowest weight of its adjoint representation. Let us establish the connection between the highest and the lowest weights of a representation.

Let  $C_0$  be the Weyl chamber corresponding to a base  $\Pi$ . Denote by  $w_0$  the (unique) element of  $W$  sending  $C_0$  to the opposite Weyl chamber  $-C_0$ . Clearly,  $w_0^2 = e$ .

**Problem 55.** The transformation  ${}^t w_0$  sends the highest weights of the representation  $R$  (or  $\rho$ ) into the lowest weights and vice versa. If  $n_0 \in N(T)$  is an element such that  $(\text{Ad } n_0)|_{\mathfrak{t}(\mathbb{R})} = w_0$  then  $R(n_0)$  transforms the highest vectors in the lowest ones and vice versa.

Problem 55 implies that the properties of the lowest weights are completely similar to the known properties of the highest weights. Thus, any weight  $\lambda$  of a representation  $R$  is expressed in the form  $\lambda = M + \alpha_{i_1} + \dots + \alpha_{i_k}$ , where  $M$  is a lowest weight and  $\alpha_{i_j} \in \Pi$ . If  $R$  is irreducible then there exists a unique lowest weight  $M \in \Phi_R$ ,  $\dim V_M = 1$  and the representation is determined by  $M$  uniquely up to an equivalence.

**Exercises**

- 1) The Lie algebra  $\hat{\mathfrak{n}}^+$  of Problem 5 is freely generated by the elements  $\hat{e}_1, \dots, \hat{e}_l$  (i.e. there exists an isomorphism  $I(x_1, \dots, x_l) \rightarrow \hat{\mathfrak{n}}^+$  sending  $x_i$  to  $\hat{e}_i$ ). Similarly,  $\hat{\mathfrak{n}}^-$  is freely generated by  $\hat{f}_1, \dots, \hat{f}_l$ .
- 2) The relations of Problem 26 together with relations (2) form the complete

set of defining relations of a semisimple Lie algebra  $\mathfrak{g}$ . (Hint: See [17], Appendix to Ch. VI).

- 3) Under the notation of 2°  $v \in \hat{V}_\lambda$  belongs to  $M^{(\lambda)}$  if and only if  $\hat{\rho}_\lambda(\hat{e}_i)v \in M^{(\lambda)}$  for all  $i$ . (This gives a recursive method for constructing  $M^{(\lambda)}$ .)
- 4) Under the notation of 2° let  $\lambda$  be a highest weight of  $\rho$  and  $\lambda$  a dominant weight of the form  $\lambda - \alpha_{i_1} - \dots - \alpha_{i_k}$ , where  $\alpha_{i_j} \in \Pi$ . Then  $\lambda \in \Phi_\rho$ . (Hint: present  $\lambda - \lambda$  as the sum of a minimal number of positive roots:  $\lambda - \lambda = \beta_1 + \dots + \beta_m$  and then by induction in  $k$  prove that  $\lambda - \beta_1 - \dots - \beta_k \in \Phi_\rho$ .)

Since any weight of  $\rho$  can be transformed into a dominant weight by a transformation from the Weyl group, we have a method for recovering all the weights of a representation from its highest weights.

In Exercises 5)–14)  $R$  stands for a finite-dimensional linear representation of a connected semisimple Lie group  $G$  in a space  $V$ ,  $\rho = dR: \mathfrak{g} \rightarrow \mathfrak{gl}(V)$  the corresponding tangent representation,  $\Pi$  a system of simple roots of  $G$ .

- 5) We have  $\Phi_{R^*} = -\Phi_R$ , where  $R^*$  is the representation dual to  $R$ . If  $R$  is the irreducible representation with the highest weight  $\lambda$  and the lowest weight  $M$  then  $R^*$  is the irreducible representation with the highest weight  $-\lambda = -{}^t w_0 \lambda$  and the lowest weight  $-M = -{}^t w_0 M$ , where  $w_0 \in W$  is the element defined in 7°.
- 6) The transformation  $\nu = -{}^t w_0$  is an automorphism of  $\Pi$ . If  $\mathfrak{g}$  is simple and different from  $\mathfrak{sl}_n(\mathbb{C})$  ( $n \geq 3$ ),  $\mathfrak{so}_{4n+2}(\mathbb{C})$  and  $E_6$  then  $\nu = e$ . For the remaining simple Lie algebras  $\nu$  is determined by the only nontrivial symmetry of the Dynkin diagram of  $\Pi$ . If  $\mathfrak{g}$  is not simple then  $\nu$  acts on  $\Pi$  componentwise. (Hint: apply Exercise 2.19).

A representation  $R$  is called *self-dual* if  $R^* \sim R$ .

- 7) If  $\mathfrak{g}$  is a simple Lie algebra different from  $\mathfrak{sl}_n(\mathbb{C})$ , ( $n \geq 3$ ),  $\mathfrak{so}_{4n+2}(\mathbb{C})$  or  $E_6$  then any irreducible representation of  $\mathfrak{g}$  is self-dual. For the remaining three types an irreducible representation is self-dual if and only if its numerical labels are symmetrically located on its Dynkin diagram.
- 8) Let  $H$  be the three-dimensional connected simple subgroup of  $G$  corresponding to the principal three-dimensional subalgebra  $\mathfrak{h} \subset \mathfrak{g}$  (see Exercise 2.28). If  $R$  is an irreducible representation with the highest weight  $\lambda$  and the lowest weight  $M$  then there exists in  $V$  a subspace invariant and irreducible with respect to  $R(H)$  and containing  $V_\lambda, V_M$ . In this subspace,  $R$  induces an irreducible representation  $R_m$  of  $H$ , where  $m = \sum_{\alpha \in \Pi} r_\alpha \lambda_\alpha$ .
- 9) A linear representation  $R$  is self-dual if and only if there exists a non-degenerate bilinear form on  $V$  invariant with respect to  $R(G)$ .
- 10) If for an irreducible representation  $R$  there exists a nonzero bilinear form on  $V$  invariant with respect to  $R(G)$  then this form is non-degenerate and either symmetric or skew-symmetric; any two invariant bilinear forms are proportional to each other.

A linear representation  $R$  is called *orthogonal* if it preserves a non-degenerate symmetric invariant bilinear form and *symplectic* if it preserves a non-degenerate skew-symmetric invariant bilinear form. Any self-dual irreducible representation is, clearly, either orthogonal or symplectic.

- 11) The representation  $R_k$  of  $SL_2(\mathbb{C})$  is orthogonal if  $k$  is even and symplectic if  $k$  is odd. Any irreducible representation of  $SO_3(\mathbb{C})$  is orthogonal. 1
- 12) Let  $R$  be an irreducible self-dual representation with highest weight  $\lambda$  and  $\lambda_\alpha = \lambda(h_\alpha)$  ( $\alpha \in \Pi$ ) the numerical labels of the highest weight.  $R$  is orthogonal if  $\sum_{\alpha \in \Pi} r_\alpha \lambda_\alpha$  is even and symplectic if this number is odd. Here  $r_\alpha$  are the coordinates of the vector  $2\rho^\vee = \sum_{\alpha \in \Delta^+} \alpha^\vee$  in the basis  $\Pi^\vee = \{h_\alpha: \alpha \in \Pi\}$ . Thanks to Exercise 2.5  $\rho^\vee = \sum_{\alpha \in \Pi} \pi_{\alpha^\vee}$ , where  $\pi_{\alpha^\vee} \in \mathfrak{t}(\mathbb{R})$  are the fundamental weights of the root system  $\Delta_g^\vee$ . 1
- 13) Deduce from Exercise 12 the following rule for determining whether a self-dual irreducible representation of  $G$  is orthogonal or symplectic. Find the sum of numerical labels of the highest weight corresponding to the black vertices in the connected components of the Dynkin diagram of  $G$  of the types indicated below (other types give zero contribution). The representation is orthogonal if and only if this sum is even and symplectic if it is odd. d

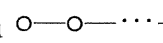
$A_{4q+1}$   (the black vertex is the middle one). 2

$B_{4q+1}, B_{4q+2}$   e

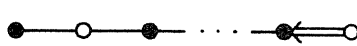
$C_{2q}$   p

$C_{2q+1}$   /

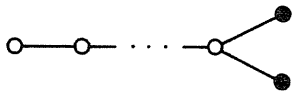
$D_{4q+2}$   2

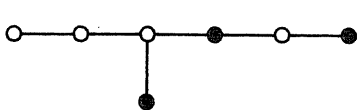
$E_7$   2

- 14) Express the criterion of Exercise 12 in the following form: let  $z_0 \in Z(G)$  be the element defined by the formula 2

$$z_0 = \mathcal{E}(\rho^\vee) = \exp(2\pi i \rho^\vee);$$

an irreducible self-dual representation  $R$  is orthogonal if  $R(z_0) = E$  and symplectic if  $R(z_0) = -E$ .

A connected semisimple Lie group  $G$  is called a *group of adjoint type* if it satisfies either of the following equivalent conditions:  $\mathcal{X}(T) = Q$  or  $Z(G) = \{e\}$  or  $\pi_1(G) \cong \pi_1(\Delta_G)$ .

- 15) For any semisimple Lie algebra  $\mathfrak{g}$  there exists a unique up to an isomorphism group of adjoint type with the tangent algebra  $\mathfrak{g}$ . Such a group is the adjoint group  $\text{Ad } G$  for any connected Lie group  $G$  with the tangent algebra  $\mathfrak{g}$ .
- 16) Any self-dual irreducible linear representation of a group of adjoint type is orthogonal.

Let  $G$  be a connected semisimple Lie group,  $R_1, \dots, R_m$  its linear representations,  $R = R_1 \dots R_m$ .

- 17) The weights of  $R$  are of the form  $\lambda_1 + \dots + \lambda_m$ , where  $\lambda_i \in \Phi_{R_i}$ . Then  $(V_1)_{\lambda_1} \otimes \dots \otimes (V_m)_{\lambda_m} \subset (V_1 \otimes \dots \otimes V_m)_{\lambda_1 + \dots + \lambda_m}$ .
- 18) If  $v_{A_i}$  is a highest vector of  $R_i$  then  $v_A = v_{A_1} \otimes \dots \otimes v_{A_m}$  is a highest vector of  $R$ .

Suppose  $G = G_1 \times \dots \times G_m$ , where  $G_i$ 's are simple groups.

For any irreducible representation  $\tilde{R}_i: G_i \rightarrow GL(V_i)$  we can define an irreducible representation  $R_i: G \rightarrow GL(V_i)$  setting  $R_i(g_1, \dots, g_n) = \tilde{R}_i(g_i)$ .

- 19) Let  $R_i: G_i \rightarrow GL(V_i)$  be an irreducible representation for each  $i = 1, \dots, m$ . Then  $R_1 \dots R_m$  is an irreducible representation of  $G$  in the space  $V_1 \otimes \dots \otimes V_m$ . Recover its highest weight from the highest weights of  $\tilde{R}_i$ 's.
- 20) Conversely, any irreducible representation of  $G$  factors into the product of  $R_i$ 's obtained by the above method from some irreducible representations  $\tilde{R}_i$  of  $G_i$ . The representations  $\tilde{R}_i$  are determined uniquely.

Let  $T^p V$  be the  $p$ -th tensor power of a vector space  $V$ . Let  $A^p V$  and  $S^p V$  be its exterior and symmetric powers. Any representation  $R: G \rightarrow GL(V)$  induces the  $p$ -th tensor power  $T^p R = R^p$  in the space  $T^p V$ , the  $p$ -th exterior power  $A^p R$  in  $A^p V$  and the  $p$ -th symmetric power  $S^p R$  in  $S^p V$ .

- 21)  $T^2 R \simeq A^2 R \oplus S^2 R$ . (For  $p > 2$  the similar statement is false!)
- 22) Find the representations of the tangent algebra  $\mathfrak{g}$  corresponding to  $A^p R$  and  $S^p R$ .
- 23)  $V_{\lambda_1} \wedge \dots \wedge V_{\lambda_p} \subset (A^p V)_{\lambda_1 + \dots + \lambda_p}$ ;  $V_{\lambda_1} \dots V_{\lambda_p} \subset (S^p V)_{\lambda_1 + \dots + \lambda_p}$ .
- 24) If  $v_A$  is a highest vector of  $R$ , then  $v_A^p$  is a highest vector of  $S^p R$  and its weight is  $pA$ .
- 25) Let  $R$  be an irreducible representation with the highest weight  $A$  and  $\{v_1, \dots, v_p\}$ , where  $v_i \in V_{\lambda_i}$ , a linearly independent system of its weight vectors with the minimal possible sum  $\sum_{1 \leq i \leq p} ht(\lambda - \lambda_i)$ , where  $ht(\gamma)$  (the height of a weight  $\gamma \in P$ ) is the sum of coordinates of  $\gamma$  in the basis consisting of simple roots. Then  $v_1 \wedge \dots \wedge v_p$  is a highest vector of  $A^p R$ .
- 26) The diagrams of the identity representations Id of the classical simple Lie groups are the following:

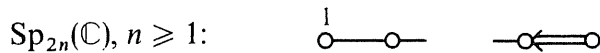
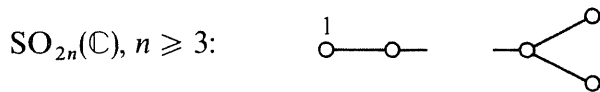
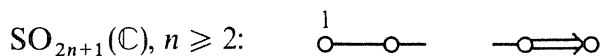
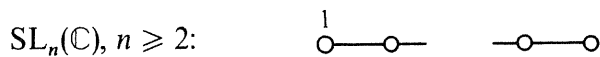

- 27) For the indicated values of  $p$  the representations  $\Lambda^p \text{Id}$  are irreducible and their diagrams are the following:

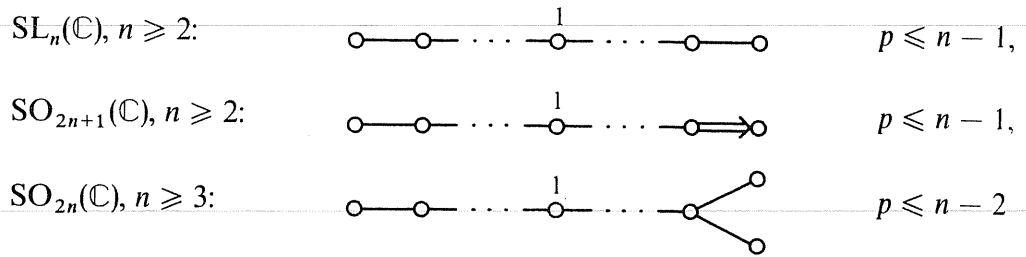

(the unit occupies the  $p$ -th place.)

- 28) The representation  $S^p \text{Id}$  of  $\text{SL}_n(\mathbb{C})$  is irreducible for all  $p$ , its diagram is  $\overset{p}{\circ} - \circ - \dots - \circ - \circ$  and  $S^p \text{Id} \sim R_p$  for  $n = 2$ .
- 29) Using Theorem 5 prove that  $\text{SL}_n(\mathbb{C})$  and  $\text{Sp}_{2n}(\mathbb{C})$  are simply connected and  $\pi_1(\text{SO}_n(\mathbb{C})) \cong \mathbb{Z}_2$  for  $n \geq 3$ .

In Exercises 30–33  $R$  is a locally faithful linear representation of a connected semisimple Lie group  $G$ ,  $\rho = dR$ ,  $T$  a maximal torus of  $G$ .

- 30) If we identify  $\mathfrak{t}(\mathbb{R})^*$  with its image with respect to  $\rho^{-1}$  then the character lattice  $\mathcal{X}(R(T))$  is identified with the sublattice  $L_R \subset \mathcal{X}(T)$  generated by the weights of  $R$ . The lattice  $L_R$  is generated by the lattice  $Q$  and all highest (or all lowest) weights of  $R$ , and the dual lattice is of the form

$$L_R^* = \{x \in p^\vee : A(x) \in \mathbb{Z} \text{ for all the highest (lowest weights of } R)\}$$

- 31)  $Z(R(G)) \cong p^\vee / L_R^* \cong L_R / Q; \quad \text{Ker } R \cong L_R^* / \mathfrak{t}(\mathbb{Z}) \cong \mathcal{X}(T) / L_R$ .
- 32) A representation  $R$  is faithful if and only if its weights generate  $\mathcal{X}(T)$  or if  $L_R^* = \mathfrak{t}(\mathbb{Z})$ .
- 33)  $R(G)$  is a group of adjoint type if and only if  $L_R = Q$ . If  $R$  is irreducible then this is equivalent to the fact that the weight system  $\Phi_R$  contains a zero weight.

Denote by  $\text{Spin}_n(\mathbb{C})$  the simply connected covering group for  $\text{SO}_n(\mathbb{C})$ ,  $n \geq 3$ .

- 34) We have the following isomorphisms:

$$\text{Spin}_3(\mathbb{C}) \cong \text{SL}_2(\mathbb{C}),$$

$$\text{Spin}_4(\mathbb{C}) \cong \text{SL}_2(\mathbb{C}) \times \text{SL}_2(\mathbb{C}),$$

$$\text{Spin}_5(\mathbb{C}) \cong \text{Sp}_4(\mathbb{C}),$$

$$\text{Spin}_6(\mathbb{C}) \cong \text{SL}_4(\mathbb{C}).$$

- 35) A connected semisimple Lie group admits a faithful irreducible representation if and only if its center is cyclic.
- 36) The following representations of  $\text{Spin}_n(\mathbb{C})$  are faithful:

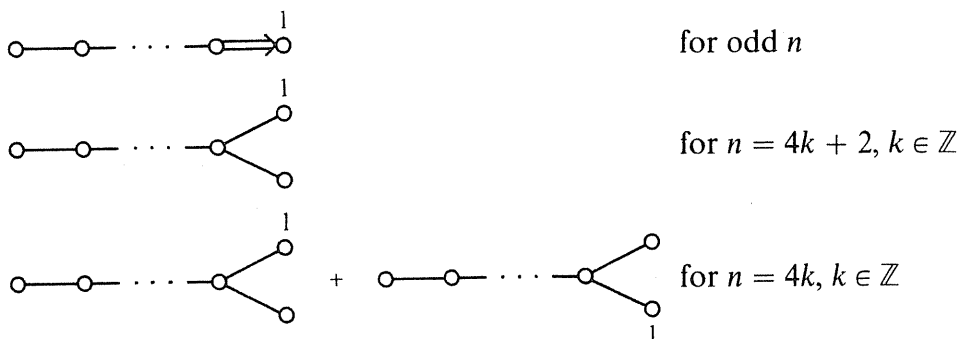

**Hints to Problems**

1. By induction in the length  $m$  of a word verify that the words of the form (1) constitute a subalgebra of  $\mathfrak{a}$ .
4. Make use of Problems 1.44 and 2.21.
5. Making use of Problem 1 and relation (2) show that  $\hat{\mathfrak{t}} + \hat{\mathfrak{n}}^+ + \hat{\mathfrak{n}}^-$  is a subalgebra of  $\hat{\mathfrak{g}}$ .
6. The identity  $\hat{\mathfrak{g}}_0 = \hat{\mathfrak{t}}$  follows from the invertibility of  $A$  and the linear independence of the elements  $\hat{h}_i$ .
8. First prove that the ideal  $\mathfrak{m} \subset \hat{\mathfrak{g}}$  does not contain any  $\hat{h}_i$  if and only if  $\mathfrak{m} \cap \hat{\mathfrak{t}} = 0$ . Then show that any ideal  $\mathfrak{m}$  is of the form  $\mathfrak{m} = \bigoplus_{\alpha} \mathfrak{m} \cap \hat{\mathfrak{g}}_{\alpha}$ . To prove that  $\mathfrak{m}^{\pm}$  are ideals notice that

$$[\hat{f}_i, \hat{\mathfrak{n}}^+] \subset \hat{\mathfrak{t}} + \hat{\mathfrak{n}}^+, \quad [\hat{e}_i, \hat{\mathfrak{n}}^-] \subset \hat{\mathfrak{t}} + \hat{\mathfrak{n}}^-.$$

9. Follows from the fact that any non-zero ideal of  $\mathfrak{g}$  contains at least one of the elements  $h_i$ .
10. Apply Problem 1.25 (more precisely, its generalization to any linear representations of  $\mathfrak{g}$ ).
11. Let  $r_i = r_{\alpha_i}$  be the reflection corresponding to the root  $\alpha_i$ . By Problem 1.40  $r_i(A) = A - A_i \alpha_i$  is a weight of the representation  $\rho$  in the subspace spanned by the vectors  $v_{i_1 \dots i_k}, v_{\emptyset}$ . By Problem 1.25  $v_{i_1 \dots i_k} \in V_{A - \alpha_{i_1} - \dots - \alpha_{i_k}}$ . This implies that  $A_i \geq 0$ .
13. Make use of Problem 3.
17. Follows from the commutative diagram of Problem 15.
18. Make use of the existence of the representation  $\hat{\rho}_{A_i}$  for any  $A_1, \dots, A_l$ .
21. Problem 8 implies that the subspace  $\rho'(m^-)(V)$  is  $\mathfrak{g}$ -invariant. If  $\rho'(m^-) \neq 0$  then  $\rho'(m^-)(V) = V, v_{\emptyset} \in \rho'(m^-)(V)$  which contradicts Problem 19. To prove that  $\rho'(m^+) = 0$  consider the subspace  $\bigcap_{x \in m^+} \text{Ker } \rho'(x)$  invariant with respect to  $\mathfrak{g}$  and containing  $v_{\emptyset}$ .
23. Prove that the elements of the form  $(\text{ad } f_{i_1}) \dots (\text{ad } f_{i_p})(\text{ad } h_{j_1}) \dots (\text{ad } h_{j_q})(x)$  ( $p, q \geq 0$ ) form an ideal of  $\mathfrak{g}$  belonging to  $\mathfrak{n}^-$ .

27. Expanding  $(\text{ad } p)^l q = 0$  we see that the product  $p^l q$  is presented in the desired form.
28. The vector  $v = p(\hat{f}_i)^{A_i+1} v_\emptyset$  is obviously a weight vector of weight  $\lambda - (A_i + 1)\alpha_i$ . By a straightforward verification  $\rho(e_k)v = 0$  for all  $k$ . Problem 19 shows that  $v = 0$ .
29. For  $\rho(e_i)$  this is clear from Problem 19. To prove the local nilpotency of  $\rho(f_i)$  consider the subspace  $U_i = \bigcup_m \text{Ker}(\rho(f_i))^m$ . Problem 28 shows that  $U_i \neq 0$ . By a straightforward verification  $U_i$  is invariant with respect to  $\rho(h_k)$  and  $\rho(e_k)$  for all  $k$ . Finally, with the help of formula (11) and Problem 27 applied to  $p = \rho(f_i)$  and  $q = \rho(f_k)$ , it is not difficult to show that  $U_i$  is invariant with respect to  $\rho(f_k)$  for any  $k$ . This implies that  $U_i = V$ .
30. It suffices to prove that any weight vector belongs to a finite-dimensional subspace invariant with respect to  $\rho(\mathfrak{g}^{(i)})$ . Let  $\lambda \in \Omega$ . Consider the subspace

$$U = V_\lambda \oplus \left( \bigoplus_m \rho(e_i)^m V_\lambda \right) \oplus \left( \bigoplus_m \rho(f_i)^m V_\lambda \right).$$

It is easy to verify that  $U$  is invariant with respect to  $\rho(\mathfrak{g}^{(i)})$  and Problems 20 and 29 imply that  $U$  is finite-dimensional.

31. It suffices to consider two cases:  $h = h_i$  and  $\alpha_i(h) = 0$ . In the first case the statement of the problem reduces to the statement concerning  $\text{SL}_2(\mathbb{C})$  which can be verified directly. In the second case it is necessary to prove that  $\rho(h)$  commutes with  $w_i$  but this follows from the fact that  $\rho(h)$  commutes with  $\rho(h_i)$ ,  $\rho(e_i)$ ,  $\rho(f_i)$ .
33. In the orbit of  $\gamma$  under  $W$ , choose an element  $\gamma_1$  with the minimal sum of the coefficients in its linear expression in terms of  $\alpha_1, \dots, \alpha_l$  and consider the elements  $r_i(\gamma_1)$ .
34. Thanks to Problems 32 and 33 we may assume that  $(\lambda, \alpha_i) \geq 0$  for all  $i$ . Making use of Problem 19 we get  $(\lambda - \lambda, \lambda) \geq 0$ .
35. Under the conditions of the problem,  $h_i \notin \text{Ker } \rho$  for any  $i$ . Then apply Problem 22.
36. Let  $\mathfrak{a}$  be a commutative ideal of  $\mathfrak{a}$  and  $\mathfrak{a} \neq 0$ . By Problem 22  $h_i \in \mathfrak{a}$  for some  $i$  but then  $e_i = \frac{1}{2}[h_i, e_i] \in \mathfrak{a}$  contradicting the commutativity of  $\mathfrak{a}$ .
38. Make use of Problem 5 and linear independence of the forms  $\alpha_1, \dots, \alpha_l$ .
41. The group  $G^{(k)}$  is the image of the simply connected group  $\text{SL}_2(\mathbb{C})$  with respect to the homomorphism  $\Phi_k = \Phi_{\alpha_k}$  (see 1.6°); it is simply connected if and only if  $\Phi_k$  is injective, i.e.  $t_k = \Phi_k(-E) \neq e$ . It is easy to see that  $t_k = \exp(\pi i h_k)$ . The condition (13) implies the existence of a character  $\chi \in \mathcal{X}(T)$  such that  $(d\chi)(h_k) = 1$ . Then  $\chi(t_k) = \exp(\pi i (d\chi)(h_k)) = -1$  so that  $t_k \neq e$ .
42. Clearly,  $T = T^{(1)} \dots T^{(l)}$ . Let  $t_k \in T^{(k)}$  be elements such that  $t_1 \dots t_l = e$ . Condition (13) implies the existence of characters  $\chi_i \in \mathcal{X}(T)$  ( $i = 1, \dots, l$ ), such that  $d\chi_i = \pi_i$  (fundamental weights). We have  $\chi_k(t_1 \dots t_l) = \chi_k(t_k) = 1$ . Let  $t_k = \exp(2\pi i c_k h_k)$ , where  $c_k \in \mathbb{C}$ . Then  $\chi_k(t_k) = \exp(2\pi i c_k)$  so that  $c_k \in \mathbb{Z}$  and  $t_k = e$ .
43. Make use of Theorems 1.2.4, 2.4 and Problem 2.27.
44. Make use of Theorem 3.1.10.

- 45. Such is e.g. the sum of the irreducible representations with highest weights  $\pi_1, \dots, \pi_l$  existing thanks to Theorem 4. The representation is faithful thanks to Problem 1.39.
- 48. Make use of the fact that  $Z(G) = \{\exp x: x \in \mathfrak{t}, e^{\alpha(x)} = 1 \text{ for all } \alpha \in \Delta_{\mathfrak{g}}\}$ .
- 49. Make use of the relation  $\text{Ker } p \subset Z(\tilde{G})$ .
- 50. Make use of Diagram (15).
- 51. Let  $p_i: \tilde{G}_i \rightarrow G_i$  be a simply connected covering of  $G_i$  ( $i = 1, 2$ ) and  $T_i \subset G_i$ ,  $\tilde{T}_i \subset \tilde{G}_i$  the maximal tori corresponding to  $\mathfrak{t}_i$ . The isomorphism  $\varphi$  determines an isomorphism  $\tilde{\Phi}: \tilde{G}_1 \rightarrow \tilde{G}_2$  such that the diagram

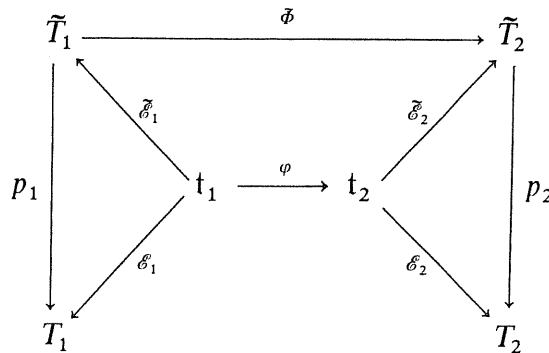

where  $\mathcal{E}_i, \tilde{\mathcal{E}}_i$  are defined as in (14), commutes (see Problem 49). Theorem 8 implies that  $\tilde{\Phi}(\text{Ker } p_1) = \text{Ker } p_2$  so that  $\tilde{\Phi}$  determines the desired isomorphism  $\Phi: G_1 \rightarrow G_2$ .

- 52. Make use of Theorem 1 and Problem 51.
- 53. Let  $A$  be the Cartan matrix of  $\mathfrak{g}$ . It follows from (2.6) that the isomorphism  $\mathbb{Z}^l \rightarrow P$  sending the set  $(k_1, \dots, k_l)$  to  $\sum_{1 \leq i \leq l} k_i \pi_i$  maps  $Q_A$  onto  $Q$  and therefore induces an isomorphism  $\pi(A) \rightarrow \pi(\Delta_{\mathfrak{g}})$ . With the subgroup  $\mathcal{X}(T)/Q \subset \pi(\Delta_{\mathfrak{g}})$  associated is an isomorphic subgroup  $Z \subset \pi(A)$ . Theorems 9 and 10 imply that the correspondence  $G \mapsto (A, Z)$  determines the desired bijection.
- 54. The uniqueness of the representation with given highest weight follows from Theorems 2 and 1.2.4. Let  $\lambda \in \mathcal{X}(T)$  be a dominant character. By Theorem 4 there exists an irreducible finite-dimensional linear representation  $\rho: \mathfrak{g} \rightarrow \text{gl}(V)$  of  $\mathfrak{g}$  with the highest weight  $\lambda$ . By Theorem 1.2.6  $p = d\tilde{R}$  for an irreducible representation  $\tilde{R}: \tilde{G} \rightarrow \text{GL}(V)$ , where  $\tilde{G}$  is a simply connected covering group of  $G$ . By Theorem 8 the kernel of the covering  $\varphi: \tilde{G} \rightarrow G$  is of the form  $\text{Ker } \varphi = \tilde{\mathcal{E}}(\mathfrak{t}(\mathbb{Z}))$ . On the other hand, it follows from Problem 10 that  $\Phi_{\tilde{R}} \in \mathcal{X}(T)$  whence we derive that  $\tilde{R}(\text{Ker } \varphi) = e$  so that  $\tilde{R}$  determines the desired linear representation  $R: G \rightarrow \text{GL}(V)$ .
- 55. Let  $B^+$  and  $B^-$  be the Borel subgroups of  $G$  corresponding to the Weyl chambers  $C_0$  and  $-C_0$  (see 2.3°). It follows from Problem 1.24 that  $n_0 B^+ n_0^{-1} = B^-$  and  $n_0 B^- n_0^{-1} = B^+$ .

## §4. Automorphisms

In this section we study automorphisms of the complex semisimple Lie algebras. First we prove that the group of outer automorphisms (see 1.3.10°) of a semisimple Lie algebra is isomorphic to the group of automorphisms of its Dynkin diagram. We then study semisimple automorphisms of a semisimple Lie algebra  $\mathfrak{g}$  up to conjugacy in  $\text{Aut } \mathfrak{g}$ . The main result is an explicit description of classes of semisimple automorphisms whose eigenvalues are of absolute value 1. This description, involving the affine Dynkin diagrams, is due (in case of periodic automorphisms) to V.G. Kac, but its proof presented in this book essentially differs from the original one (for an exposition of the latter see [6]) and goes back to the well-known paper by F.R. Gantmacher [38]. Especially important for us is the description of classes of involutive automorphisms since it will be used in Ch. 5 in the classification of real simple Lie algebras. At the end of the section we consider semisimple automorphisms of simply connected semisimple Lie groups and we prove that the set of fixed points of such an automorphism is connected. All Lie groups and Lie algebras are defined over  $\mathbb{C}$ ;  $(\cdot, \cdot)$  denotes the Cartan scalar product on a semisimple Lie algebra.

**1°. The Group of Outer Automorphisms.** Let  $\mathfrak{g}$  be a semisimple Lie algebra. In this section we calculate the group  $\text{Aut } \mathfrak{g}/\text{Int } \mathfrak{g}$  of its outer automorphisms (see 1.3.10°). As it is known,  $\text{Aut } \mathfrak{g}$  is a linear algebraic group whose tangent algebra is the algebra of derivations  $\text{der } \mathfrak{g}$ . The ideal  $\text{ad } \mathfrak{g} \subset \text{der } \mathfrak{g}$  is isomorphic to  $\mathfrak{g}$  and therefore is algebraic. Clearly, the corresponding connected algebraic normal subgroup of  $\text{Aut } \mathfrak{g}$  coincides with  $\text{Int } \mathfrak{g}$ .

Let  $\mathfrak{h}$  be a maximal diagonalizable subalgebra in  $\mathfrak{g}$ . Let  $\Delta_{\mathfrak{g}}$  be the root system with respect to  $\mathfrak{h}$  and  $\Pi \subset \Delta_{\mathfrak{g}}$  a base. Each automorphism  $\theta \in \text{Aut } \mathfrak{g}$  is the differential  $d\Theta$  of an automorphism  $\Theta$  of the connected algebraic group  $G$  with the tangent algebra  $\mathfrak{g}$  (e.g. of the automorphism  $\Theta(a) = \theta a \theta^{-1}$  of  $G = \text{Int } \mathfrak{g}$ ). Applying Problem 1.24 we see that if  $\theta(\mathfrak{h}) = \mathfrak{h}$  then  $\theta(\mathfrak{h}(\mathbb{R})) = \mathfrak{h}(\mathbb{R})$  and  $\theta(\Delta_{\mathfrak{g}}) = \Delta_{\mathfrak{g}}$ . Since  $\theta$  preserves the Cartan scalar product,  $\theta \in \text{Aut } \Delta_{\mathfrak{g}}$ . Now consider the subgroup

$$\text{Aut}(\mathfrak{g}, \mathfrak{h}, \Pi) = \{\theta \in \text{Aut } \mathfrak{g} : \theta(\mathfrak{h}) = \mathfrak{h}, \theta(\Pi) = \Pi\}.$$

Assigning to an automorphism  $\theta \in \text{Aut}(\mathfrak{g}, \mathfrak{h}, \Pi)$  the automorphism  $(\theta|_{\Pi})^{-1} \in \text{Aut } \Pi$  we get a homomorphism

$$\eta: \text{Aut}(\mathfrak{g}, \mathfrak{h}, \Pi) \rightarrow \text{Aut } \Pi.$$

Let us prove that  $\eta$  is surjective. For this fix a canonical system of generators  $\{h_{\alpha}, e_{\alpha}, e_{-\alpha} (\alpha \in \Pi)\}$  of  $\mathfrak{g}$  associated with  $\mathfrak{h}$  and  $\Pi$  (see 3.2°). By Theorem 3.1 for any  $\tau \in \text{Aut } \Pi$  there exists a unique automorphism  $\hat{\tau} \in \text{Aut}(\mathfrak{g}, \mathfrak{h}, \Pi)$  such that

$$\hat{\tau}(h_{\alpha}) = h_{\tau^{-1}(\alpha)}, \quad \hat{\tau}(e_{\alpha}) = e_{\tau^{-1}(\alpha)}, \quad \hat{\tau}(e_{-\alpha}) = e_{-\tau^{-1}(\alpha)} \quad (\alpha \in \Pi). \quad (1)$$

Clearly, the map  $\zeta: \tau \mapsto \hat{\tau}$  is a homomorphism of  $\text{Aut } \Pi$  into  $\text{Aut}(\mathfrak{g}, \mathfrak{h}, \Pi)$  such that  $\eta\zeta = \text{id}$ . We see that  $\eta$  isomorphically maps the subgroup  $\widehat{\text{Aut}} \Pi = \text{Im } \zeta \subset \text{Aut}(\mathfrak{g}, \mathfrak{h}, \Pi)$  onto  $\text{Aut } \Pi$ . It is also clear that

$$\text{Aut}(\mathfrak{g}, \mathfrak{h}, \Pi) = \text{Ker } \eta \rtimes \widehat{\text{Aut}} \Pi.$$

Denote by  $H = \exp \text{ad } \mathfrak{h}$  the maximal torus of  $\text{Int } \mathfrak{g}$  corresponding to  $\text{ad } \mathfrak{h} \simeq \mathfrak{h}$ . Clearly,  $H \subset \text{Ker } \eta$ .

**Problem 1.**  $\text{Ker } \eta = \text{Aut}(\mathfrak{g}, \mathfrak{h}, \Pi) \cap \text{Int } \mathfrak{g} = H$ , therefore  $\text{Aut}(\mathfrak{g}, \mathfrak{h}, \Pi) = H \rtimes \widehat{\text{Aut}} \Pi$ .

Now we extend  $\eta$  to a homomorphism of the whole group  $\text{Aut } \mathfrak{g}$  onto  $\text{Aut } \Pi$  (the extended homomorphism will be denoted by the same letter  $\eta$ ).

**Problem 2.**  $\text{Aut } \mathfrak{g} = \text{Aut}(\mathfrak{g}, \mathfrak{h}, \Pi) \cdot \text{Int } \mathfrak{g}$ .

Problems 1 and 2 imply

**Theorem 1.**  $\text{Aut } \mathfrak{g} = \text{Int } \mathfrak{g} \rtimes \widehat{\text{Aut}} \Pi$ . In particular,  $\text{Aut } \mathfrak{g} / \text{Int } \mathfrak{g} \simeq \text{Aut } \Pi$ . The corresponding homomorphism  $\eta: \text{Aut } \mathfrak{g} \rightarrow \text{Aut } \Pi$  coincides with  $\eta: \theta \mapsto (\theta|_{\Pi})^{-1}$  on  $\text{Aut}(\mathfrak{g}, \mathfrak{h}, \Pi)$ .

**Problem 3 (Corollary).** The group  $\text{Int } \mathfrak{g}$  coincides with the identity component of  $\text{Aut } \mathfrak{g}$  and the different connected components of  $\text{Aut } \mathfrak{g}$  are the sets  $\eta^{-1}(\tau) = (\text{Int } \mathfrak{g})\hat{\tau}$  for different  $\tau \in \text{Aut } \Pi$ . The Lie algebra  $\mathfrak{der } \mathfrak{g}$  coincides with  $\text{ad } \mathfrak{g}$ .

**2°. Semisimple Automorphisms.** Let  $\theta$  be an automorphism of a semisimple Lie algebra  $\mathfrak{g}$  which is a semisimple linear transformation,  $\mathfrak{g}(\lambda) \subset \mathfrak{g}$  the eigenspace of  $\theta$  corresponding to  $\lambda \in \mathbb{C}^*$ . Then

$$\mathfrak{g} = \bigoplus_{\lambda \in \mathbb{C}^*} \mathfrak{g}(\lambda).$$

**Problem 4.**  $[\mathfrak{g}(\lambda), \mathfrak{g}(\mu)] \subset \mathfrak{g}(\lambda\mu)$  for any  $\lambda, \mu \in \mathbb{C}^*$ . In particular,  $\mathfrak{g}(1) = \{x \in \mathfrak{g}: \theta(x) = x\}$  is a subalgebra of  $\mathfrak{g}$ .

Denote  $\mathfrak{g}(1)$  by  $\mathfrak{g}^\theta$ .

**Problem 5.**  $(\mathfrak{g}(\lambda), \mathfrak{g}(\mu)) = 0$  for any  $\lambda, \mu$  such that  $\lambda\mu \neq 1$ . The scalar product is non-degenerate on  $\mathfrak{g}(\lambda) + \mathfrak{g}(1/\lambda)$  for any  $\lambda \in \mathbb{C}^*$ .

**Theorem 2.** If  $\mathfrak{g} \neq 0$  is a semisimple Lie algebra and  $\theta \in \text{Aut } \mathfrak{g}$  is a semisimple automorphism then  $\mathfrak{g}^\theta \neq 0$ .

Proof of this theorem is an immediate corollary of the following Problems 6–9.

**Problem 6.** Any nilpotent element  $x \in \mathfrak{g}$  presents in the form  $x = [x, y]$ , where  $y \in \mathfrak{g}$ .

**Problem 7.** If  $\mathfrak{g}^\theta = 0$  then  $\mathfrak{g}(\lambda)$  does not contain non-zero nilpotent elements for any  $\lambda \in \mathbb{C}^*$ .

**Problem 8.** If  $\lambda \in \mathbb{C}^*$  is not a root of 1 then  $\mathfrak{g}(\lambda)$  consists of nilpotent elements.

If all eigenvalues of  $\theta$  are roots of 1 then, clearly,  $\theta^m = e$  for certain positive integer  $m$  so that all eigenvalues are of the form  $\varepsilon^l$ , where  $\varepsilon = e^{2\pi i/m}$ .

**Problem 9.** If  $\theta^m = e$  and  $\mathfrak{g}(\varepsilon^l) = 0$  for  $0 \leq l < k < m$  then  $\mathfrak{g}(\varepsilon^k)$  consists of nilpotent elements.

**Problem 10.** The subalgebra  $\mathfrak{g}^\theta$  is a reductive algebraic subalgebra of  $\mathfrak{g}$ .

Our aim is the classification of semisimple automorphisms up to conjugacy in  $\text{Aut } \mathfrak{g}$ . The first step in this direction is the proof of the fact that any semisimple automorphism  $\theta$  is conjugate to an element of  $\text{Aut}(\mathfrak{g}, \mathfrak{h}, \Pi)$  where  $\mathfrak{h}$  and  $\Pi$  are defined in 1°. For this we make use of  $\mathfrak{g}^\theta$ . Let  $\mathfrak{t}$  be a maximal diagonalizable subalgebra of  $\mathfrak{g}^\theta$  and  $\mathfrak{z}(\mathfrak{t})$  its centralizer in  $\mathfrak{g}$ .

**Problem 11.** The subalgebra  $\mathfrak{z}(\mathfrak{t})$  is invariant with respect to  $\theta$  and is a maximal diagonalizable subalgebra of  $\mathfrak{g}$ .

**Problem 12.** In  $\mathfrak{t}$ , there exists an element regular with respect to  $\mathfrak{h}_1 = \mathfrak{z}(\mathfrak{t})$ . There exists a system of simple roots  $\Pi_1$  of  $\mathfrak{g}$  with respect to  $\mathfrak{h}_1$  such that  $\theta(\Pi_1) = \Pi_1$ .

**Problem 13.** There exists  $a \in \text{Int } \mathfrak{g}$  such that  $a\theta a^{-1} \in H\hat{\tau} \subset \text{Aut}(\mathfrak{g}, \mathfrak{h}, \Pi)$ , where  $\tau = \eta(\theta)$ .

Therefore it suffices to consider automorphisms taken from cosets  $H\hat{\tau} = \hat{\tau}H$ , where  $\tau$  are different elements of  $\text{Aut } \Pi$ . Denote by  $T_\tau$  the subtorus of  $H$  which is the identity component of the subgroup  $Z(\hat{\tau}) = \{h \in H: \tau h \tau^{-1} = h\}$ . Clearly,  $T_\tau = \exp(\text{ad } \mathfrak{t}_\tau)$ , where  $\mathfrak{t}_\tau = \mathfrak{h}^\tau = \mathfrak{h} \cap \mathfrak{g}^\tau$ . Now we wish to show that any element of  $\hat{\tau}H$  is conjugate to an element of the subset  $\hat{\tau}T_\tau$ .

**Problem 14.** The subspace  $\text{Im}(\tau - e) \subset \mathfrak{h}$  coincides with  $\mathfrak{t}_\tau^\perp$ . The torus  $H$  locally splits into the direct product of tori:  $H = T_\tau H_1$ , where  $H_1 = \{\hat{\tau}^{-1} h \hat{\tau} h^{-1}: h \in H\}$ .

**Problem 15.** For any  $\theta \in \hat{\tau}H$  there exists  $h \in H$  such that  $h\theta h^{-1} \in \hat{\tau}T_\tau$ . In particular,  $\hat{\tau}H$  consists of semisimple automorphisms.

Problems 13 and 15 imply

**Theorem 3.** Any semisimple automorphism  $\theta \in \text{Aut } \mathfrak{g}$  is conjugate to an automorphism from the set  $\hat{\tau}T_\tau$ , where  $\tau = \eta(\theta)$ ,  $T_\tau = \exp(\text{ad } \mathfrak{h}^\tau)$ .

**Problem 16.** If automorphisms  $a_1, a_2 \in \text{Aut } \mathfrak{g}$  are conjugate in  $\text{Aut } \mathfrak{g}$  then  $\eta(a_1), \eta(a_2)$  are conjugate in  $\text{Aut } \Pi$ . Conversely, if  $\tau_2 = \sigma \tau_1 \sigma^{-1}$ , where  $\tau_1, \tau_2, \sigma \in \text{Aut } \Pi$ , then  $\hat{\tau}_2 T_{\tau_2} = \hat{\sigma}(\hat{\tau}_1 T_{\tau_1})\hat{\sigma}^{-1}$ .

Theorem 3 and Problem 16 imply that the problem of classification of semisimple automorphisms of  $\mathfrak{g}$  up to conjugacy reduces to the following two problems:

- find the conjugacy classes of  $\text{Aut } \Pi$ ;
- for some representatives  $\tau$  of various conjugacy classes of  $\text{Aut } \Pi$  classify the elements of  $\hat{\tau}T_\tau$  up to conjugacy in  $\text{Aut } \mathfrak{g}$ .

Problem a) belongs to the theory of finite groups. We will only consider this problem for simple Lie algebras  $\mathfrak{g}$ , when it is trivial. Most of this section is devoted to the solving of Problem b).

Let again  $\tau \in \text{Aut } \Pi$ . Consider the automorphism  $\hat{\tau}$  and the subspace  $\mathfrak{t}_\tau = \mathfrak{h}^{\hat{\tau}}$ . Let  $r: \mathfrak{h}^* \rightarrow \mathfrak{t}_\tau^*$  be the restriction map. Clearly,  $r(\Delta_{\mathfrak{g}}(\mathfrak{h}) \cup \{0\}) = \Delta(\mathfrak{t}_\tau) \cup \{0\}$ .

**Problem 17.**  $\dim \mathfrak{t}_\tau$  equals the number of orbits of the cyclic group  $\langle \tau \rangle$  in  $\Pi$ . For  $\alpha, \beta \in \Pi$  we have  $r(\alpha) = r(\beta)$  if and only if  $\alpha$  and  $\beta$  belong to the same orbit. If  $\alpha \in \Delta_{\mathfrak{g}}(\mathfrak{h})$  and  $r(\alpha) \in r(\Pi)$  then  $\alpha \in \Pi$ . The different elements of  $\Pi_0 = r(\Pi)$  form a basis of  $\mathfrak{t}_\tau^*$  and each element of  $r(\Delta_{\mathfrak{g}})$ , the set coinciding with  $\Delta(\mathfrak{t}_\tau)$ , is expressed in terms of elements of  $\Pi_0$  with integer coefficients of the same sign. The centralizer  $\mathfrak{z}(\mathfrak{t}_\tau)$  coincides with  $\mathfrak{h}$ . For any  $\theta \in \hat{\tau}H$  the subalgebra  $\mathfrak{t}_\tau$  is a maximal diagonalizable subalgebra of  $\mathfrak{g}^\theta$ .

**Problem 18.** Let automorphisms  $\theta_1, \theta_2 \in \hat{\tau}T_\tau$  be conjugate in  $\text{Aut } \mathfrak{g}$ , i.e.  $\theta_2 = g\theta_1g^{-1}$  for some  $g \in \text{Aut } \mathfrak{g}$ . The automorphism  $g$  can be chosen so that  $g(\mathfrak{t}_\tau) = \mathfrak{t}_\tau$ ,  $g\hat{\tau}g^{-1} \in \hat{\tau}T_\tau$ .

In  $\text{Aut } \mathfrak{g}$ , consider the subgroup  $S_\tau = \langle \hat{\tau} \rangle T_\tau$ . Clearly,  $S_\tau = \langle \hat{\tau} \rangle \times T_\tau$ . Therefore  $S_\tau$  is a quasitorus in  $\text{Aut } \mathfrak{g}$  and  $S_\tau^0 = T_\tau$  (see 3.2.3°). Let  $N_\tau$  be the subgroup of the normalizer  $N(S_\tau)$  of  $S_\tau$  in  $\text{Aut } \mathfrak{g}$  consisting of  $g \in N(S_\tau)$  such that  $a(g)$  transforms  $\hat{\tau}T_\tau$  into itself, i.e. induces the identity automorphism of  $S_\tau/T_\tau$ . Let  $\Omega_\tau$  be the group of automorphisms  $\omega(g)$  of  $S_\tau$  induced by the automorphisms  $a(g)$  for  $g \in N_\tau$ . Problem 18 implies

**Theorem 4.** Two automorphisms  $\theta_1, \theta_2 \in \hat{\tau}T_\tau$  are conjugate in  $\text{Aut } \mathfrak{g}$  if and only if  $\theta_2 = \omega(\theta_1)$  for some  $\omega \in \Omega_\tau$ .

To describe the orbits of the group  $\Omega_\tau$  on the set  $\hat{\tau}T$  it is convenient to go over to the simply connected covering space  $\mathfrak{a}$  of the manifold  $\hat{\tau}T_\tau$ , which is an affine space with the associated vector space  $\mathfrak{t}_\tau$ . Here, instead of  $\Omega_\tau$ , the group of transformations of  $\mathfrak{a}$  covering the transformations from  $\Omega_\tau$  is to be considered. This group turns out to be very close to the group of affine transformations generated by reflections with respect to some affine hyperplanes. These hyperplanes correspond to some affine functions on  $\mathfrak{a}$ , which will be called affine roots of the pair  $(\mathfrak{g}, \tau)$ . The following two subsections are concerned with the construction of affine roots and the corresponding root decomposition.

**3°. Characters and Automorphisms of Quasi-Tori.** Consider an algebraic quasitorus of the form

$$S = \langle a \rangle \times T,$$

where  $T = S^0$  is a torus and  $a$  an element of order  $k$ . Let  $\mathfrak{t}$  be the tangent algebra of the groups  $T$  and  $S$ . As we have seen in 3.3.2°, any character  $\chi$  of  $T$  is uniquely determined by its differential  $d_e \chi \in \mathfrak{t}^*$ . We want to show that any character of the quasi-torus  $S$  is determined by a family of affine functions on an affine space with the associated vector space  $\mathfrak{t}$ .

Denote  $A = aT$  and let  $\pi: \mathfrak{a} \rightarrow A$  be a covering with the simply connected covering space  $\mathfrak{a}$ . Observe that  $\mathfrak{t}$  may be considered as the simply connected covering space of  $T$ , the covering  $\mathcal{E}: \mathfrak{t} \rightarrow T$  being defined as  $\mathcal{E}(x) = \exp(2\pi ix)$ . Let  $\mu: T \times A \rightarrow A$  be the natural simply transitive action of the group  $T$  on  $A$ , i.e.  $\mu(t, b) = bt$ . Fix a point  $\tilde{a} \in \mathfrak{a}$ , such that  $\pi(\tilde{a}) = a$ . By the property (F) of simply connected coverings (see 1.3.3°) there exists a unique differentiable map  $\tilde{\mu}: \mathfrak{t} \times \mathfrak{a} \rightarrow \mathfrak{a}$  covering  $\mu$  and such that  $\tilde{\mu}(0, \tilde{a}) = \tilde{a}$ .

**Problem 19.** The map  $\tilde{\mu}$  is a simply transitive action of the group  $\mathfrak{t}$  on  $\mathfrak{a}$  and thus defines on  $\mathfrak{a}$  a structure of an affine space with the associated vector space  $\mathfrak{t}$ . The action  $\tilde{\mu}$  does not depend on the choice of a point  $\tilde{a}$  such that  $\pi(\tilde{a}) = a$ .

Denote by  $t_x: \mathfrak{a} \rightarrow \mathfrak{a}$  the translation by  $x \in \mathfrak{t}$ , i.e. set

$$t_x(y) = \tilde{\mu}(x, y) \quad (x \in \mathfrak{t}, y \in \mathfrak{a}).$$

A character  $\lambda \in \mathcal{X}(S)$  is uniquely determined by its values on  $A$ . In fact, if  $\lambda|_A$  is known, then so is  $\lambda(a) \in \mathbb{C}^*$  and for any  $t \in T$  we know  $\lambda(t) = \lambda(at)\lambda(a)^{-1}$ . Consider the covering  $\mathcal{E}: \mathbb{C} \rightarrow \mathbb{C}^*$  defined by the formula  $\mathcal{E}(z) = 2\pi iz$ . By the property (F) of simply connected covering spaces there exists a differentiable function  $\tilde{\lambda}: \mathfrak{a} \rightarrow \mathbb{C}$  covering  $\lambda$ . This function is uniquely determined by its value  $\tilde{\lambda}(\tilde{a})$  which is chosen up to an arbitrary integer summand.

**Problem 20.** Any function  $\tilde{\lambda}$  covering  $\lambda \in \mathcal{X}(S)$  is an affine function with the linear part  $d\lambda \in \mathfrak{t}^*$  and  $\tilde{\lambda}(\tilde{a}) \in \frac{1}{k}\mathbb{Z}$ . Conversely, an affine function  $\xi: \mathfrak{a} \rightarrow \mathbb{C}$  such that  $\xi(\tilde{a}) \in \frac{1}{k}\mathbb{Z}$  whose linear part is the differential of a character of  $T$  covers some character of the quasi-torus  $S$ .

Set

$$\mathfrak{a}(\mathbb{R}) = \{y \in \mathfrak{a}: \tilde{\lambda}(y) \in \mathbb{R} \text{ for any } \lambda \in \mathcal{X}(S)\}.$$

**Problem 21.** We have  $\mathfrak{a}(\mathbb{R}) = \{t_x(\tilde{a}): x \in \mathfrak{t}(\mathbb{R})\}$ . Thus  $\mathfrak{a}(\mathbb{R})$  is a real affine space with the associated vector space  $\mathfrak{t}(\mathbb{R})$ . Each function  $\tilde{\lambda}$  covering  $\lambda \in \mathcal{X}(S)$  is completely determined by its restriction to  $\mathfrak{a}(\mathbb{R})$ .

Therefore, to each character  $\lambda \in \mathcal{X}(S)$  we have assigned a family of real affine functions on  $\mathfrak{a}(\mathbb{R})$ , any two of them differing by an integer summand. Any of these functions  $\tilde{\lambda}$  completely determines  $\lambda$ .

Similar considerations may be applied to the automorphisms of the quasi-torus  $S$  transforming  $A$  into itself, i.e. identical on  $S/T$ . An automorphism  $\varphi$  of this sort is uniquely determined by its restriction to  $A$ . Moreover, the transformation  $\varphi|_A$  admits a covering  $\tilde{\varphi}: \mathfrak{a} \rightarrow \mathfrak{a}$ , which is uniquely determined by its value  $\tilde{\varphi}(\tilde{a}) = z$ . The element  $z \in \mathfrak{a}$  may be an arbitrary element satisfying  $\pi(z) = \varphi(a)$ .

**Problem 22.** Any covering transformation  $\tilde{\varphi}: \mathfrak{a} \rightarrow \mathfrak{a}$  is affine and has  $d_e\varphi$  as its linear part. The transformation  $\tilde{\varphi}$  maps  $\mathfrak{a}(\mathbb{R})$  onto itself and is uniquely determined by its restriction to  $\mathfrak{a}(\mathbb{R})$ .

**4°. Affine Root Decomposition.** Now we consider the quasi-torus  $S_\tau = \langle \hat{t} \rangle \times T_\tau$ , where  $\tau$  is a fixed automorphism of a system of simple roots  $\Pi$  (see 2°). The tangent algebra of  $S_\tau$  is  $\text{ad } t_\tau$ . It is convenient to identify it with  $t_\tau$  with the help of the isomorphism  $\text{ad}$ . Thus in our case  $t = t_\tau$ . We also have  $A = \hat{t}T_\tau$ ,  $a = \hat{t}$ .

For any affine space  $B$  over a field  $k$  denote by  $B^\wedge$  the vector space of all affine functions  $B \rightarrow k$ . Clearly,  $\dim B^\wedge = \dim B + 1$ . If  $\varphi: B_1 \rightarrow B_2$  is an affine map of affine spaces then the formula

$$({}'\varphi(\alpha))(x) = \alpha(\varphi(x))$$

determines a linear map  $'\varphi: B_2^\wedge \rightarrow B_1^\wedge$ .

Let  $\Psi \subset \mathcal{X}(S)$  be the set of all weights of the identity representation of  $S$  in  $\mathfrak{g}$ . Then

$$\mathfrak{g} = \bigoplus_{\lambda \in \Psi} \mathfrak{g}^\lambda,$$

where  $\mathfrak{g}^\lambda \neq 0$  is the weight subspace corresponding to  $\lambda$ . The affine functions  $\tilde{\lambda} \in \mathfrak{a}(\mathbb{R})$  corresponding to the weights  $\lambda \in \Psi$  will be called *affine roots* of the pair  $(\mathfrak{g}, \tau)$ ; the set of all affine roots will be denoted by  $\Delta^\tau \subset \mathfrak{a}(\mathbb{R})^\wedge$ . Since the affine root  $\tilde{\lambda}$  covering a weight  $\lambda$  is completely determined by its linear part  $\alpha = d\lambda$  and the number  $s = \tilde{\lambda}(\tilde{a})$ , we write  $\tilde{\lambda} = (\alpha, s)$ . Clearly, here  $\alpha \in \Delta(t_\tau) \cup \{0\}$  is a weight of the identity representation of  $\text{Int}(\mathfrak{g})$  with respect to  $T_\tau$  and  $s \in \frac{1}{k}\mathbb{Z}$ , where  $k$  is the order of  $\tau$ . We will write  $\mathfrak{g}^{\tilde{\lambda}} = \mathfrak{g}^\lambda$ . If  $(\alpha, s) \in \Delta^\tau$  then  $(\alpha, s + m) \in \Delta^\tau$  for any  $m \in \mathbb{Z}$  and  $\mathfrak{g}^{(\alpha, s)} = \mathfrak{g}^{(\alpha, s+m)}$ . We have  $\mathfrak{g} = \sum_{\xi \in \Delta^\tau} \mathfrak{g}^\xi$ .

**Problem 23.**  $\Delta^\tau$  generates  $\mathfrak{a}(\mathbb{R})^\wedge$ .

**Problem 24.** If  $\xi = (\alpha, s) \in \Delta^\tau$  then  $\mathfrak{g}^\xi = \mathfrak{g}_\alpha \cap \mathfrak{g}(\varepsilon^s)$ , where  $\mathfrak{g}_\alpha$  is the root subspace corresponding to  $\alpha \in \Phi_{\text{ad}}$  and  $\mathfrak{g}(\varepsilon^s)$  is the eigenspace of  $\hat{t}$  with  $\varepsilon = e^{2\pi i/k}$ . Furthermore,

$$\mathfrak{g}(\varepsilon^s) = \sum_{\xi=(\alpha, s)} \mathfrak{g}^\xi, \quad \mathfrak{g}_\alpha = \sum_{\xi=(\alpha, s)} \mathfrak{g}^\xi$$

**Problem 25.** For any  $\xi, \eta \in \Delta^\tau$  we have

$$[\mathfrak{g}^\xi, \mathfrak{g}^\eta] \begin{cases} \subset \mathfrak{g}^{\xi+\eta} & \text{if } \xi + \eta \in \Delta^\tau. \\ = 0 & \text{otherwise.} \end{cases}$$

The roots with zero linear parts are called *imaginary* and the other roots are called *real* ones. Denote the sets of imaginary and real roots by  $\Delta_{\text{im}}^\tau$  and  $\Delta_{\text{re}}^\tau$  respectively. Problem 24 implies that

$$\mathfrak{h} = \sum_{\xi \in \Delta_{\text{im}}^\tau} \mathfrak{g}^\xi$$

It turns out that the real roots have a number of properties similar to the usual properties of roots and weights. To prove this we will make use of some three-dimensional subalgebras of  $\mathfrak{g}$  as in 1.6°. For any  $\xi = (\alpha, s)$ ,  $\eta = (\beta, t) \in \mathcal{A}^r$  write  $\langle \xi, \eta \rangle = \langle \alpha, \beta \rangle$ ,  $\langle \xi | \eta \rangle = \langle \alpha | \beta \rangle$ . If  $\xi \in \mathcal{A}_{re}^r$  then the element  $h_\alpha \in \mathfrak{t}_r(\mathbb{R})$  determined by (1.5) will also be denoted by  $h_\xi$ .

**Problem 26.** For any  $\xi \in \mathcal{A}^r$  we have  $-\xi \in \mathcal{A}^r$ . If  $\xi \in \mathcal{A}_{re}^r$  then  $[\mathfrak{g}^\xi, \mathfrak{g}^{-\xi}] = \langle h_\xi \rangle$ .

Let  $e_\xi \in \mathfrak{g}^\xi$ ,  $e_{-\xi} \in \mathfrak{g}^{-\xi}$  be elements such that  $[e_\xi, e_{-\xi}] = h_\xi$ . Then the map  $\psi_\xi: \mathfrak{sl}_2(\mathbb{C}) \rightarrow \mathfrak{g}$  defined by the formulas

$$\psi_\xi(\mathbf{e}) = e_\xi, \quad \psi_\xi(\mathbf{f}) = e_{-\xi}, \quad \psi_\xi(\mathbf{h}) = h_\xi$$

is an isomorphism of  $\mathfrak{sl}_2(\mathbb{C})$  onto the subalgebra  $\langle e_\xi, e_{-\xi}, h_\xi \rangle \subset \mathfrak{g}$ .

Let  $\xi \in \mathcal{A}_{re}^r$ ,  $\eta \in \mathcal{A}^r$ . The set  $\{\zeta \in \mathcal{A}^r: \zeta = \eta + l\xi (l \in \mathbb{Z})\}$  is called the  $\xi$ -string of roots through  $\eta$ .

**Problem 27.** Let  $\xi \in \mathcal{A}_{re}^r$ . Then the  $\xi$ -string of roots through  $\eta \in \mathcal{A}^r$  is of the form  $\{\eta + l\xi (-p \leq l \leq q)\}$ , where  $p, q \geq 0$  and  $p - q = \langle \eta | \xi \rangle$ . If  $\langle \eta, \xi \rangle < 0$  then  $\eta + \xi \in \mathcal{A}^r$ , and if  $\langle \eta, \xi \rangle > 0$  then  $\eta - \xi \in \mathcal{A}^r$ .

**Problem 28.** For any  $\xi \in \mathcal{A}_{re}^r$  we have  $\dim \mathfrak{g}^\xi = 1$ . If  $\xi \in \mathcal{A}_{re}^r$ ,  $c \in \mathbb{R}$  then  $c\xi \in \mathcal{A}^r$  if and only if  $c = -1, 0, 1$ .

**Problem 29.** Under the notation of Problem 28 we have  $(\text{ad } e_\xi)^{p+q} \mathfrak{g}^{\eta-p\xi} \neq 0$ . If  $\xi \in \mathcal{A}_{re}^r$  and  $\eta, \eta + \xi \in \mathcal{A}^r$  then  $[\mathfrak{g}^\xi, \mathfrak{g}^\eta] \neq 0$  and if  $\zeta + \eta \in \mathcal{A}_{re}^r$  then  $[\mathfrak{g}^\xi, \mathfrak{g}^\eta] = \mathfrak{g}^{\zeta+\eta}$ .

In  $\mathfrak{g}$ , consider the reductive algebraic subalgebra  $\mathfrak{g}^{\hat{\tau}} = \mathfrak{g}(1)$ . By Problem 17  $\mathfrak{t}_\tau = \mathfrak{g}^{(0,0)}$  is a maximal diagonalizable subalgebra of  $\mathfrak{g}^{\hat{\tau}}$ . Problem 24 implies that

$$\mathfrak{g}^{\hat{\tau}} = \bigoplus_{\xi=(\alpha,0)} \mathfrak{g}^\xi \quad (2)$$

**Problem 30.** The subalgebra  $\mathfrak{g}^{\hat{\tau}}$  has the zero centralizer in  $\mathfrak{g}$  and, in particular, is semisimple. The system  $\Pi_0 = r(\Pi)$  is its system of simple roots with respect to  $\mathfrak{t}_\tau$ . The root system  $\Delta_{\mathfrak{g}^{\hat{\tau}}}$  coincides with the set of  $\alpha \in \mathfrak{t}(\mathbb{R})^*$  such that  $(\alpha, 0) \in \mathcal{A}_{re}^r$ .

A root  $\xi = (\alpha, s) \in \mathcal{A}^r$  is called *positive* if either  $s = 0$  and  $\alpha$  belongs to the set  $\Delta_{\mathfrak{g}^{\hat{\tau}}}$  of positive (with respect to  $\Pi_0$ ) roots of  $\mathfrak{g}^{\hat{\tau}}$  or  $s > 0$ . If  $\mathcal{A}^{r+}$  is the set of all positive roots then  $\mathcal{A}^r = \mathcal{A}^{r+} \cup \{0\} \cup (-\mathcal{A}^{r+})$ . A positive root is called *simple* if it does not split into the sum of two positive roots. Let  $\Pi^r \subset \mathcal{A}^{r+}$  be the system of simple roots. Clearly,  $(\alpha, 0) \in \Pi^r$  if  $\alpha \in \Pi_0$ . If  $\xi, \eta \in \Pi^r$  and  $\xi \neq \eta$  then  $\xi - \eta \in \mathcal{A}^r$ .

Problem 4 applied to  $\theta = \hat{\tau}$  implies that for any  $s = m/k$ , where  $m \in \mathbb{Z}$ , the adjoint representation of  $\mathfrak{g}^{\hat{\tau}}$  in  $\mathfrak{g}$  transforms the eigenspace  $\mathfrak{g}(\varepsilon^s)$  of  $\hat{\tau}$  into itself. The corresponding representation of  $\mathfrak{g}^{\hat{\tau}}$  in  $\mathfrak{g}(\varepsilon^s)$  will be denoted by  $\text{ad}_s$ . Clearly,  $(\alpha, 1) \in \mathcal{A}^r \Leftrightarrow \alpha \in \Phi_{\text{ad}_s}$ . Now we will establish the relationship between simple roots and lowest weights of the representations  $\text{ad}_s$ . (See 3.7°.)

**Problem 31.** The lowest weights of all representations  $\text{ad}_s$  are non-zero.

**Problem 32.** If  $(\alpha, s) \in \Pi^\tau$  and  $s > 0$  then  $\alpha$  is a lowest weight of the representation  $\text{ad}_s$ . In particular,  $\Pi^\tau \subset \Delta_{\text{re}}^\tau$ . If  $\alpha$  is a lowest weight of  $\text{ad}_s$ , then  $(\alpha - \alpha', s) \notin \Delta^\tau$  for all  $\alpha' \in \Delta_{\mathfrak{g}}^\tau$ . If, moreover,  $(\beta, t) \notin \Delta^\tau$  for all  $\beta \neq 0$  and  $0 < t < s$  then  $\gamma = (\alpha, s) \in \Pi^\tau$  and  $e_\gamma$  is the corresponding lowest vector.

**Problem 33.** Any  $\xi \in \Delta^{\tau+}$  presents in the form  $\xi = \sum_{\gamma \in \Pi^\tau} k_\gamma \gamma$ , where  $k_\gamma$  are non-negative integers.

**5°. Affine Weyl Group.** Let again  $\mathfrak{a}$  be the complex affine space covering the manifold  $A = \hat{\tau}T_\tau$ ,  $\mathfrak{a}(\mathbb{R})$  its real form defined in 3°. Notice that the associated vector space  $\mathfrak{t}_\tau(\mathbb{R})$  is a Euclidean space with respect to the Cartan scalar product on  $\mathfrak{g}$ . So  $\mathfrak{a}(\mathbb{R})$  is an affine Euclidean space. Denote by  $I(\mathfrak{a}(\mathbb{R}))$  its group of motions.

Let  $\tilde{\Omega}_\tau$  be the set of all affine transformations  $\tilde{\omega}$  of  $\mathfrak{a}$  covering the transformations  $\omega|_A$ , where  $\omega \in \Omega_\tau$ . By Problem 22 we may identify  $\tilde{\Omega}_\tau$  with the corresponding set of transformations of  $\mathfrak{a}(\mathbb{R})$ .

**Problem 34.** The set  $\tilde{\Omega}_\tau$  is a subgroup of  $I(\mathfrak{a}(\mathbb{R}))$ . The natural homomorphism  $\tilde{\Omega}_\tau \rightarrow \Omega_\tau$  is surjective and its kernel is  $\{t_x: x \in \mathfrak{t}_\tau(\mathbb{Z})\}$ .

**Problem 35.** For any  $w \in \tilde{\Omega}_\tau$  we have  $w(\Delta^\tau) = \Delta^\tau$ . If  $w = \tilde{\omega}(g)$ , where  $g \in N_\tau$ , then  $g(g^\xi) = g^{t_w^{-1}(\xi)}$  ( $\xi \in \Delta^\tau$ ).

The definition of  $\tilde{\Omega}_\tau$  easily implies that Theorem 4 can be reformulated as follows:

**Theorem 4'.** The automorphisms  $\theta_1 = \pi(y_1)$ ,  $\theta_2 = \pi(y_2)$ , where  $y_1, y_2 \in \mathfrak{a}$ , are conjugate in  $\text{Aut } \mathfrak{g}$  if and only if  $y_2 = w(y_1)$  for some  $w \in \tilde{\Omega}_\tau$ .

Each real root  $\xi \in \Delta_{\text{re}}^\tau$  determines the hyperplane  $P_\xi = \{y \in \mathfrak{a}(\mathbb{R}): \xi(y) = 0\}$  in  $\mathfrak{a}(\mathbb{R})$ . The connected components of the set  $\mathfrak{a}(\mathbb{R}) \setminus \bigcup_{\xi \in \Delta_{\text{re}}^\tau} P_\xi$  will be called *chambers*. Clearly, the chambers are open convex sets in  $\mathfrak{a}(\mathbb{R})$ . Problem 35 implies that  $\tilde{\Omega}_\tau$  permutes the hyperplanes  $P_\xi$  and chambers. Let us show that it acts transitively on the set of all chambers. To this end denote by  $r_\xi$  the orthogonal reflection with respect to the hyperplane  $P_\xi$ , where  $\xi \in \Delta_{\text{re}}^\tau$ , and prove that  $r_\xi \in \tilde{\Omega}_\tau$ .

Consider the homomorphism  $\varphi_\xi = (\text{ad} \cdot \psi_\xi: \mathfrak{sl}_2(\mathbb{C}) \rightarrow \text{ad } \mathfrak{g}$  (see Problem 26) and denote by  $\Phi_\xi: \text{SL}_2(\mathbb{C}) \rightarrow \text{Int } \mathfrak{g}$  the Lie group homomorphism such that  $d\Phi_\xi = \varphi_\xi$ . Let  $n_\xi = \Phi_\xi \left( \begin{pmatrix} 0 & 1 \\ -1 & 0 \end{pmatrix} \right) \in \text{Int } \mathfrak{g}$ .

**Problem 36.** We have  $n_\xi(\mathfrak{t}_\tau) = \mathfrak{t}_\tau$ . If  $\xi = (\alpha, s)$  then  $n_\xi|_{\mathfrak{t}(\mathbb{R})}$  coincides with the reflection  $r_\alpha$  with respect to the hyperplane  $\text{Ker } \alpha$ .

**Problem 37.** If  $\xi = (\alpha, s)$  then

$$n_\xi \hat{\tau} n_\xi^{-1} = \hat{\tau} \mathcal{E}(-sh_\xi). \tag{3}$$

Therefore  $n_\xi \in N_\tau$ . The reflection  $r_\xi$  covers the transformation  $\omega(n_\xi)$  and therefore belongs to  $\tilde{\Omega}_\tau$ .

Let  $W_\tau$  be the subgroup of  $\tilde{\Omega}_\tau$  generated by the reflections  $r_\xi$  for all  $\xi \in \Delta_{\text{re}}^\tau$ . The group  $W_\tau$  is called the *affine Weyl group* associated with  $\tau \in \text{Aut } \Pi$ .

Now we will establish certain properties of the affine Weyl groups similar to those of the Weyl groups (see 2.4°). In precisely the same way as for the Weyl chambers we define the notion of a *wall of a chamber*.

**Problem 38.** The walls of any chamber are of the form  $P_\xi$ , where  $\xi \in \Delta_{rc}^\tau$ . Conversely, any hyperplane  $P_\xi$ ,  $\xi \in \Delta_{rc}^\tau$ , is a wall of a chamber.

**Theorem 5.**  $W_\tau$  acts simply transitively on the set of all chambers. If  $D_0$  is a fixed chamber and  $P_{\xi_1}, \dots, P_{\xi_s}$ , where  $\xi_1, \dots, \xi_s \in \Delta_{rc}^\tau$ , are its walls then the reflections  $r_{\xi_1}, \dots, r_{\xi_s}$  generate the group  $W_\tau$ .

**Theorem 6.** The closure  $\bar{D}$  of any chamber  $D$  is a fundamental set for the group  $W_\tau$ , i.e. intersects each orbit of this group at a single point.

**Problem 39.** Let  $y_1, y_2 \in \bar{D}$ , where  $D$  is a chamber, and let  $w \in \tilde{\Omega}_\tau$  be such that  $y_2 = w(y_1)$ . Then  $w$  can be chosen so that  $w(D) = D$ .

Now, show that the system of simple roots  $\Pi^\tau$  defined in 4° determines a chamber  $D_0$  in the same way as any system of simple roots of a usual root system determines a certain Weyl chamber (see 2.2°). Set

$$D_0 = \{y \in \mathfrak{a}(\mathbb{R}) : \gamma(y) > 0 \text{ for all } \gamma \in \Pi^\tau\}. \quad (4)$$

Let us prove that  $D_0 \neq \emptyset$ . From formula (2) we see that the correspondence  $\alpha \mapsto (\alpha, 0)$  is a bijection of the root system  $\Delta_{g^\tau}$  of  $\mathfrak{g}^\tau$  with respect to  $\mathfrak{t}_\tau$  onto the subset of affine roots of the form  $(\alpha, 0)$ ,  $\alpha \neq 0$ . The bijection  $x \mapsto t_x(\tilde{a})$  of the space  $\mathfrak{t}_\tau(\mathbb{R})$  onto  $\mathfrak{a}(\mathbb{R})$  maps the hyperplane  $P_\alpha = \text{Ker } \alpha$  onto  $P_{(\alpha, 0)}$  and the Weyl chamber  $\{x \in \mathfrak{t}_\tau(\mathbb{R}) : \alpha(x) > 0 \text{ for all } \alpha \in \Pi_0\}$  onto an open cone  $C_0 \subset \mathfrak{a}(\mathbb{R})$  with vertex  $\tilde{a}$ . Clearly,  $D_0 \supset U \cap C_0 \neq \emptyset$ .

Our arguments also imply that the Weyl group  $W(\mathfrak{g}^\tau)$  of  $\mathfrak{g}^\tau$  is identified with the subgroup of  $W_\tau$  generated by the reflections of the form  $r_{(\alpha, 0)}$ ,  $(\alpha, 0) \in \Delta_{rc}^\tau$ .

**Problem 40.** The set  $D_0$  defined by (4) is a chamber. We have

$$\bar{D}_0 = \{y \in \mathfrak{a}(\mathbb{R}) : \gamma(y) \geq 0 \text{ for all } \gamma \in \Pi^\tau\}.$$

The chamber  $D_0$  defined by formula (4) will be called the *fundamental chamber*.

Clearly, any element  $x \in \mathfrak{t}_\tau$  is uniquely expressed in the form  $x = u + iv$ , where  $u, v \in \mathfrak{t}_\tau(\mathbb{R})$ . We will write  $u = \text{Re } x$ ,  $v = \text{Im } x$ . Any  $y \in \mathfrak{a}$  is uniquely expressed in the form  $y = t_{iv}(z)$ , where  $v \in \mathfrak{t}_\tau(\mathbb{R})$ ,  $z \in \mathfrak{a}(\mathbb{R})$ . We write  $z = \text{Re } y$ .

An automorphism  $\theta \in \hat{\tau}T_\tau$  will be called *canonical* if  $\theta = \pi(y)$  where  $y \in \mathfrak{a}$  and  $\text{Re } y \in \bar{D}_0$ . Theorems 4', 6 and Problem 39 imply.

**Theorem 7.** Any automorphism from  $\hat{\tau}T_\tau$  is conjugate to a canonical automorphism. If canonical automorphisms  $\theta_1 = \pi(y_1)$  and  $\theta_2 = \pi(y_2)$ , where  $y_i \in \tilde{\mathfrak{t}}$ ,  $\text{Re } y_i \in \bar{D}_0$  ( $i = 1, 2$ ), are conjugate then there exists a motion  $w \in \tilde{\Omega}_\tau$  mapping  $D_0$  onto itself such that  $w(\text{Re } y_1) = \text{Re } y_2$ .

Let us consider the case  $\tau = \text{id}$ . In this case  $\tilde{\mathfrak{t}}(\mathbb{R})$  coincides with the Euclidean vector space  $\mathfrak{h}(\mathbb{R})$  considered as an affine Euclidean space. The system of real

roots is of the form

$$\Delta_{re}^{id} = \{(\alpha, s): \alpha \in \Delta_{\mathfrak{g}}, s \in \mathbb{Z}\}.$$

We will denote the group  $W_{id}$  by  $\tilde{W}$ . It contains the Weyl group  $W$  of the root system  $\Delta_{\mathfrak{g}}$  as a subgroup.

**Problem 41.**  $r_{(\alpha,s)}r_{\alpha} = t_{-sh_{\alpha}}$  for any  $\alpha \in \Delta_{\mathfrak{g}}$  and  $s \in \mathbb{Z}$ .

**Problem 42.** The group  $\tilde{W}$  splits into the semidirect product  $\tilde{W} = Q^{\vee} \rtimes W$  (here  $Q$  is identified with the corresponding group of parallel translations in the space  $\mathfrak{h}(\mathbb{R})$ ).

**Problem 43.** Let  $\tau = id$  and let  $D$  be an arbitrary chamber. Then the set  $\bar{D} \cap Q^{\vee}$  consists of a single point.

**6°. Affine Roots of a Simple Lie Algebra.** In this subsection we assume that  $\mathfrak{g}$  is simple and we find an explicit form of the system of simple roots  $\Pi^{\tau}$  and the fundamental chamber for all  $\tau \in \text{Aut } \Pi$ .

**Problem 44.** For any  $\tau \in \text{Aut } \Pi$  the algebra  $\mathfrak{g}^{\hat{\tau}}$  is simple.

The groups  $\text{Aut } \Pi$  of all simple Lie algebras are listed in Table 3. This list shows that a non-trivial automorphism  $\tau \in \text{Aut } \Pi$  exists only when  $\mathfrak{g}$  is a Lie algebra of type  $A_n$  ( $n \geq 2$ ),  $D_n$  or  $E_6$ . For all these algebras except  $D_4$  there exists a unique automorphism  $\tau \neq id$  of order 2. If  $\mathfrak{g} = D_4$  then in  $\text{Aut } \Pi \simeq S_3$  there exist, beside  $\{id\}$ , two classes of conjugate elements containing all elements of order 2 and 3 respectively. Thus  $k$  can only equal 1, 2, 3.

**Problem 45.** The set  $\Delta_{im}^{\tau}$  is the cyclic subgroup of  $\mathfrak{a}(\mathbb{R})^{\wedge}$  generated by the root  $(0, 1/k)$ .

Let  $\Pi^{\tau} \subset \Delta^{\tau}$  be the system of simple roots defined in 4°. Problem 27 implies that  $(\xi, \eta) \leq 0$  for any  $\xi, \eta \in \Pi^{\tau}$ ,  $\xi \neq \eta$ . Therefore the linear parts of the roots of  $\Pi^{\tau}$  (non-zero by Problem 32) are different and constitute non-acute angles. Let  $\Psi \subset \Delta(\mathfrak{t}_{\tau})$  be the system of linear parts of affine simple roots.

**Problem 46.** Let  $\Pi_0 = \{\alpha_1, \dots, \alpha_l\}$ . The system of simple roots  $\Pi^{\tau}$  is of the form  $\Pi^{\tau} = \{\gamma_0, \gamma_1, \dots, \gamma_l\}$ , where  $\gamma_j = (\alpha_j, 0)$  ( $j = 1, \dots, n$ ),  $\gamma_0 = (\alpha_0, 1/k)$ ,  $\alpha_0$  is the (unique) lowest weight of the representation  $\text{ad}_{1/k}$ . The system  $\Psi = \{\alpha_0, \alpha_1, \dots, \alpha_l\}$  is indecomposable. The system  $\Pi^{\tau}$  is linearly independent and forms a basis of  $\mathfrak{a}(\mathbb{R})^{\wedge}$ . If  $\tau = id$  then  $\alpha_0$  is the lowest root and  $\Psi = \tilde{\Pi}$  is the extended system of simple roots of  $\mathfrak{g}$ .

**Problem 47.**

$$\alpha_0 = - \sum_{1 \leq j \leq l} n_j \alpha_j, \tag{5}$$

where  $n_j$  are positive integers. If we set  $n_0 = 1$  then

$$\sum_{0 \leq j \leq l} n_j \gamma_j = (0, 1/k). \tag{6}$$

**Problem 48.** The matrix  $A$  of  $\Psi$  with the elements  $a_{ij} = \langle \alpha_i | \alpha_j \rangle$  is an indecomposable affine Cartan matrix.

Recall that all indecomposable affine Cartan matrices were listed in 2.7°. Now we will find the affine Dynkin diagrams corresponding to the automorphisms  $\tau \in \text{Aut } \Pi$ . It suffices to choose a representative of each conjugacy class of elements of  $\text{Aut } \Pi$ .

**Problem 49.** To the above mentioned automorphisms  $\tau \in \text{Aut } \Pi$  the affine Dynkin diagrams denoted in Table 6 by  $L_n^{(k)}$ , where  $L_n$  is the type of a simple Lie algebra  $\mathfrak{g}$  and  $k$  is the order of  $\tau$  correspond. Thereby, to the identity automorphism of the system of simple roots of  $L_n$  the extended Dynkin diagrams  $L_n^{(1)}$  corresponds.

In Table 6 listed are also the numbers  $m_j$  defined in Problem 47. By Problem 2.43 these numbers are uniquely determined by  $\Psi$  as non-zero and non-negative relatively prime coefficients of a  $\mathbb{Z}$ -linear relation between the elements of this system.

Problem 49 implies that any connected affine Dynkin diagram corresponds to an automorphism  $\tau$  associated with a simple Lie algebra. Therefore there is a bijection between the automorphisms of the systems of simple roots of simple Lie algebras considered up to conjugacy and the connected affine Dynkin diagrams.

**Problem 50.** The fundamental chamber  $D_0$  is a simplex and under the notation of Problem 46 it is determined by the inequalities

$$\gamma_j(y) > 0 \quad (j = 0, 1, \dots, l).$$

The walls of  $D_0$  are the hyperplanes  $P_{\gamma_j}$  ( $j = 0, 1, \dots, l$ ).

**7°. Classification of Unitary Automorphisms of Simple Lie Algebras.** An automorphism  $\theta \in \text{Aut } \mathfrak{g}$  is called *unitary* if  $\theta$  is semisimple and all its eigenvalues  $\mu$  satisfy  $|\mu| = 1$ . For instance, any automorphism of finite order is unitary. In this section we will describe the classes of conjugate unitary automorphisms of simple Lie algebras  $\mathfrak{g}$ . By theorem 3 and Problem 16 it suffices to consider the unitary automorphisms taken from the sets  $\hat{\tau}T_\tau$ , where  $\tau$  runs over the set of representatives of classes of conjugate elements of  $\text{Aut } \Pi$ ,  $\Pi$  being a system of simple roots of  $\mathfrak{g}$ , and by Theorem 7 we may confine ourselves to canonical automorphisms.

**Problem 51.** An automorphism  $\theta = \pi(y)$ , where  $y \in \mathfrak{a}$ , is unitary if and only if  $y \in \mathfrak{a}(\mathbb{R})$ . In particular, the canonical unitary automorphisms are the automorphisms of the form  $\pi(y)$ , where  $y \in \bar{D}_0$ .

Let  $\mathfrak{g}$  be simple. Then by Problem 46 the system of simple roots  $\Pi^\tau \subset \mathcal{A}^\tau$  is of the form  $\Pi^\tau = \{\gamma_0, \gamma_1, \dots, \gamma_l\}$ , where

$$\gamma_0 = (\alpha_0, 1/k), \quad \gamma_j = (\alpha_j, 0) \quad (j = 1, \dots, l)$$

$\{\alpha_1, \dots$   
pletely  
(6) we

Thank

Clearl  
 $u \in \hat{\tau}(\Pi$

A c  
nume  
to this  
on the  
a sim  
are ca  
diagra

**Pro**  
where  
by iso

No

**The**  
and  $\pi$   
isomo  
tween  
type I  
k. Un  
are K  
diagr

Pro

**Pro**  
 $\hat{\tau}(\mathbb{R})^*$   
that  $\tau$

For  
numb  
hand,  
Probl  
 $\beta \in \Pi$   
any  $\alpha$

**Pro**

there

$\{\alpha_1, \dots, \alpha_l\} = \Pi_0$  is a system of simple roots of  $\mathfrak{g}^{\hat{t}}$ . An element  $u \in \mathfrak{a}(\mathbb{R})$  is completely determined by the real numbers  $u_j = \gamma_j(u)$  ( $j = 1, \dots, l$ ). Set  $u_0 = \gamma_0(y)$ . By (6) we have

$$\sum_{0 \leq j \leq l} n_j u_j = 1/k. \tag{7}$$

Thanks to Problem 40 the condition  $y \in \bar{D}_0$  is expressed in the form

$$u_j \geq 0 \quad (j = 0, 1, \dots, l). \tag{8}$$

Clearly, for any  $u_j \in \mathbb{R}$  ( $j = 0, 1, \dots, l$ ) satisfying (7) and (8) there exists a unique  $u \in \hat{\mathfrak{t}}(\mathbb{R})$  for which  $\gamma_j(u) = u_j$  ( $j = 0, 1, \dots, l$ ).

A connected affine Dynkin diagram whose vertices are endowed with real numerical labels  $u_j$  satisfying (7) and (8), where  $k$  is the number corresponding to this diagram, will be called a *Kac diagram*. Clearly, the Kac diagrams based on the affine Dynkin diagram corresponding to an automorphism  $\tau \in \text{Aut } \Pi$  for a simple Lie algebra  $\mathfrak{g}$  depict different elements of  $\bar{D}_0 \subset \mathfrak{a}(\mathbb{R})$ . Two Kac diagrams are called *isomorphic* if there is an isomorphism of the underlying affine Dynkin diagrams such that the corresponding vertices are endowed with the same labels.

**Problem 52.** If  $\mathfrak{g}$  is simple and canonical automorphisms  $\theta_1 = \pi(y_1)$ ,  $\theta_2 = \pi(y_2)$ , where  $\text{Re } y_1, \text{Re } y_2 \in \bar{D}_0$ , are conjugate in  $\text{Aut } \mathfrak{g}$ , then  $\text{Re } y_1, \text{Re } y_2$  are depicted by isomorphic Kac diagrams.

Now we formulate the main result of this section.

**Theorem 8.** *Let  $\mathfrak{g}$  be simple. Then two unitary canonical automorphisms  $\pi(y_1)$  and  $\pi(y_2)$  are conjugate in  $\text{Aut } \mathfrak{g}$  if and only if  $y_1, y_2 \in \bar{D}_0$  are depicted by isomorphic Kac diagrams. Therefore there exists a bijective correspondence between the classes of conjugate unitary automorphisms of a simple Lie algebra of type  $L_n$  and the classes of isomorphic Kac diagrams of types  $L_n^{(k)}$  for all possible  $k$ . Under this correspondence with the classes of inner automorphisms associated are Kac diagrams of type  $L_n^{(1)}$  and to the classes of outer automorphisms Kac diagrams of types  $L_n^{(2)}$  and  $L_n^{(3)}$  correspond.*

Proof is based on Problems 53–56.

**Problem 53.** Let  $\mathfrak{g}$  be simple and let  $\zeta \in \text{Aut } \mathcal{P}$  be a linear transformation of  $\mathfrak{t}_\tau(\mathbb{R})^*$ . Then there exists an automorphism  $n \in N_\tau$  of  $\mathfrak{g}$  commuting with  $\hat{t}$  such that  ${}^t n = \zeta$  in  $\mathfrak{t}_\tau(\mathbb{R})^*$ .

For any  $\alpha \in \Delta(\mathfrak{t}_\tau)$  set  $k_\alpha = \dim \mathfrak{g}_\alpha$ . Problems 24 and 28 imply that  $k_\alpha$  equals the number of residue classes  $s + k\mathbb{Z} \in \mathbb{Z}/k\mathbb{Z}$  such that  $(\alpha, s/k) \in \Delta^+$ . On the other hand,  $k_\alpha$  coincides with the number of  $\beta \in \Delta_\mathfrak{g}$  such that  $r(\beta) = \alpha$ . If  $\alpha \in \Pi_0$ , then Problem 17 implies that  $k_\alpha$  is the length of the orbit with respect to  $\langle \tau \rangle$  of any  $\beta \in \Pi$  such that  $r(\beta) = \alpha$ . In particular,  $k_\alpha | k$ . If  $\mathfrak{g}$  is simple then  $k_\alpha = 1$  or  $k$  for any  $\alpha \in \Pi_0$ .

**Problem 54.** Let  $v \in \mathfrak{t}_\tau(\mathbb{R})$  be a vector such that  $\alpha(v) \in \frac{1}{k_\alpha} \mathbb{Z}$  for all  $\alpha \in \Pi_0$ . Then there exists  $x \in \mathfrak{h}$  orthogonal to  $\mathfrak{t}_\tau$  such that  $v - x \in \mathfrak{h}(\mathbb{Z})$ .

**Problem 55.** Let  $v \in \mathfrak{t}_\tau(\mathbb{R})$  satisfy the conditions of Problem 54. Then  $t_v = \widetilde{\omega}(h)$  for some  $h \in H \cap N_\tau$ .

**Problem 56.** Let a motion  $w \in I(\mathfrak{a}(\mathbb{R}))$  be such that  ${}^t w(\Pi^\tau) = \Pi^\tau$ . Then  $w \in \widetilde{\mathcal{Q}}_\tau$ .

*Proof of Theorem 8.* By Problem 52 it remains to prove that if  $y_1$  and  $y_2$  are depicted by isomorphic Kac diagrams then  $\pi(y_1)$  and  $\pi(y_2)$  are conjugate. The isomorphism of the Kac diagrams determines an affine transformation  $w$  of  $\mathfrak{a}(\mathbb{R})$  such that  $y_2 = w(y_1)$  and  ${}^t w(\Pi^\tau) = \Pi^\tau$ , and that the corresponding linear transformation  $\zeta$  belongs to  $\text{Aut } \mathcal{P}$ . By Problem 53  $\zeta$  is an orthogonal transformation, hence  $w$  is a motion. By Problem 56  $w \in \widetilde{\mathcal{Q}}_\tau$ , and the theorem follows from Theorem 4'.  $\square$

A special class of unitary automorphisms is formed by the finite order automorphisms.

**Problem 57.** Let  $\mathfrak{g}$  be a simple Lie algebra,  $m$  a positive integer. The order of a unitary canonical automorphism  $\theta \in \text{Aut } \mathfrak{g}$  equals  $m$  if and only if the numerical labels on the corresponding Kac diagram are of the form  $u_j = s_j/m$ , where  $s_j$  ( $j = 0, 1, \dots, l$ ) are non-negative relatively prime integers, such that

$$m = k \sum_{0 \leq j \leq l} n_j s_j. \quad (9)$$

Problem 57 implies that the Kac diagram corresponding to a periodic automorphism is completely determined by the underlying affine Dynkin diagram and a set of relatively prime non-negative integers  $s_0, s_1, \dots, s_l$ . If we want to classify automorphisms of order  $m$  they should satisfy condition (9).

### 8°. Fixed Points of Semisimple Automorphisms of a Simply Connected Group.

Let  $G$  be a simply connected semisimple complex Lie group. Recall (see 1.2.10°) that the group  $\text{Aut } G$  of automorphisms of  $G$  is naturally isomorphic to the group  $\text{Aut } \mathfrak{g}$  of automorphisms of its tangent algebra. By Corollary of Theorem 3.6,  $G$  is an algebraic group and by Theorem 3.3.4 any automorphism of  $G$  is polynomial. An automorphism  $\Theta$  of  $G$  is called *semisimple* if so is the corresponding automorphism  $\theta = d\Theta \in \text{Aut } \mathfrak{g}$ .

The aim of this subsection is to prove that the algebraic subgroup  $G^\theta \subset G$  consisting of the fixed points of a semisimple automorphism  $\theta \in \text{Aut } \mathfrak{g}$  is connected. By Problem 1.2.31 the tangent algebra of this subgroup coincides with  $\mathfrak{g}^\theta$ . Applying Theorem 2 and Problem 10 we see that  $G^\theta$  is reductive and of positive dimension if  $G \neq \{e\}$ .

**Theorem 9.** *If  $\theta$  is a semisimple automorphism of a simply connected semisimple Lie group  $G$  then  $G^\theta$  is connected.*

Let  $g$  be a semisimple element of  $G$ . Then the inner automorphism  $a(g)$  is semisimple so that the subgroup  $Z(g) = G^{a(g)}$  is reductive. By Corollary 1 of Theorem 3.3.9 there exists a maximal torus  $H$  of  $G$  such that  $g \in H \subset Z(g)^0$ . An

element  $g$  is called *regular* if  $H = Z(g)^0$  and *singular* otherwise. Clearly, the regularity (or singularity) of an element is preserved under the action of any automorphism of  $G$ . In particular, two conjugate semisimple elements of  $G$  are either simultaneously regular or simultaneously singular. Therefore in order to describe the set of singular elements it suffices to describe singular elements belonging to a fixed maximal torus.

As above, consider the covering  $\mathcal{E}: \mathfrak{h} \rightarrow H$  defined by the formula  $\mathcal{E}(x) = \exp(2\pi i x)$ . Problem 3.46 and Theorem 3.5 imply that  $\text{Ker } \mathcal{E}$  coincides with the lattice  $Q^\vee$  generated by the dual root system  $\Delta_{\mathfrak{g}}^\vee(\mathfrak{h})$ . For any  $\alpha \in \Delta_{\mathfrak{g}}$  and  $s \in \mathbb{Z}$  denote by  $P_{(\alpha, s)}$  the hyperplane in  $\mathfrak{h}$  (not in  $\mathfrak{h}(\mathbb{R})$  as in 5°), defined by the equation  $\alpha(x) + s = 0$ . Clearly,  $x \in P_{(\alpha, s)} \Leftrightarrow \text{Re } x \in P_{(\alpha, s)}$  and  $\text{Im } x \in P_{(\alpha, 0)} = P_\alpha$ .

**Problem 58.** An element  $\mathcal{E}(x)$ , where  $x \in \mathfrak{h}$ , is singular if and only if  $x \in P_{(\alpha, s)}$  for some  $\alpha \in \Delta_{\mathfrak{g}}$  and  $s \in \mathbb{Z}$ .

*Proof of Theorem 9.* By Theorem 3.2.1 every unipotent element of an algebraic group belongs to its identity component. Thanks to the Jordan decomposition (Theorem 3.2.6), it suffices to prove that every semisimple element  $g \in G^\theta$  belongs to  $(G^\theta)^0$ .

First let  $g$  be a regular element of  $G$  and  $H = Z(g)^0$  the unique maximal torus that contains it. Then  $\Theta(H) = H$ . Consider  $x \in \mathfrak{h}$  such that  $g = \mathcal{E}(x)$ . Problem 58 implies that  $\text{Re } x$  belongs to one of the chambers  $D$  into which the space  $\mathfrak{h}(\mathbb{R})$  is divided by the hyperplanes  $P_{(\alpha, s)}$ . Since the boundary of every chamber contains an element of  $Q^\vee$ , we may assume that  $0 \in \bar{D}$ . The identities  $\mathcal{E}(\theta(x)) = \Theta(\mathcal{E}(x)) = \mathcal{E}(x)$  imply that  $y = \theta(x) - x \in Q^\vee$ . Clearly,  $\theta$  transforms  $\mathfrak{h}(\mathbb{R})$  into itself, permutes the hyperplanes  $P_{(\alpha, s)}$  and the chambers. Since  $y = \theta(\text{Re } x) - \text{Re } x$ , the chamber  $\theta(D) = D + y$  contains on its boundary the points 0 and  $y$  of the lattice  $Q^\vee$ . Problem 43 implies that  $y = 0$ . Therefore  $x \in \mathfrak{h}^\theta$  and  $g \in \mathcal{E}(\mathfrak{h}^\theta) = (H^\theta)^0 \subset (G^\theta)^0$ .

Now consider the general case. Set  $U = Z(g)^0$ . Then  $\Theta(U) = U$ . A maximal torus of  $U^\theta$  will be denoted by  $S$ .

**Problem 59.** The group  $H = (Z(g) \cap Z(S))^0$  is a maximal torus of  $G$  containing  $g$  and  $S$ .

Let us prove that the coset  $gS \subset H$  contains a regular element. Let all elements of this coset be singular. Choose  $x \in \mathfrak{h}$  such that  $g = \mathcal{E}(x)$ . Then by Problem 58 the plane  $x + \mathfrak{s}$  is contained in one of the hyperplanes  $P_{(\alpha, s)}$ .

**Problem 60.** If  $x + \mathfrak{s} \subset P_{(\alpha, s)}$  then  $G^{(\alpha)} \subset H$ .

Since  $G^{(\alpha)}$  is a simple three-dimensional subgroup, this contradicts Problem 59. Therefore there exists  $s_0 \in S$  such that  $gs_0$  is a regular element. Since  $gs_0 \in G^\theta$  the above implies that  $gs_0 \in (G^\theta)^0$ . Therefore  $g \in (G^\theta)^0$ , too. Theorem 9 is proved.  $\square$

This proof is due essentially to A. Borel. For another proof of this theorem (in a somewhat more general setting) see [48].

Concluding, let us show how to calculate the subalgebra  $\mathfrak{g}^\theta$  for a unitary canonical automorphism  $\theta$  of a simple Lie algebra  $\mathfrak{g}$  with the help of the Kac

diagram. Let  $u_0, u_1, \dots, u_n$  be the numerical labels of the Kac diagram of  $\theta$  such that  $u_{i_1} = \dots = u_{i_t} = 0$  and the other  $u_j \neq 0$ .

**Problem 61.**  $\dim Z(\mathfrak{g}^\theta) = n - t$  and the derived algebra  $(\mathfrak{g}^\theta)'$  is a semisimple subalgebra of  $\mathfrak{g}$  whose system of simple roots is  $\{\alpha_{i_1}, \dots, \alpha_{i_t}\}$ . The Dynkin diagram of  $(\mathfrak{g}^\theta)'$  is the part of the Dynkin diagram of the system  $\Psi = \{\alpha_0, \alpha_1, \dots, \alpha_n\}$  formed by the vertices with the numbers  $i_1, \dots, i_t$  and the edges that connect these vertices.

**Exercises**

In exercises 1–4 the notation of subsections 2°–5° is used.

- 1) If  $y \in \mathfrak{a}(\mathbb{R})$  is stable with respect to some  $w \in W_\tau$  then  $w$  is the product of reflections with respect to the hyperplanes  $P_\xi$  passing through  $y$ .
- 2) The group  $W_\tau$  does not contain reflections with respect to the hyperplanes different from  $\mathfrak{p}_\xi$  ( $\xi \in \Delta_{\tau c}^r$ ).

In Exercises 3–16 we assume that  $\mathfrak{g}$  is simple and we use the notation of 6° and 7°. In particular,  $\Psi = \{\alpha_0, \alpha_1, \dots, \alpha_l\}$  and  $A = (a_{ij})$  is the matrix of  $\Psi$ . As it is known, the angle between  $\alpha_i$  and  $\alpha_j$  equals  $\theta_{ij} = \pi(1 - 1/n_{ij})$ , where  $n_{ii} = 1$ ,  $n_{ij} = 2, 3, 4, 6, \infty$  ( $i \neq j$ ), if  $m_{ij} = a_{ij}a_{ji} = 0, 1, 2, 3, 4$  respectively. Set  $r_i = r_{\gamma_i}$  ( $i = 0, 1, \dots, l$ ). By Theorem 5 and Problem 46 the  $r_i$ 's generate  $W_\tau$ .

- 3) The generators  $r_i$  ( $i = 0, 1, \dots, l$ ) of  $W_\tau$  satisfy the relations

$$(r_i r_j)^{n_{ij}} = e \tag{11}$$

for any  $i, j = 0, 1, \dots, n$  such that  $n_{ij} < \infty$ .

Consider the group  $\hat{W}$  with generators  $\hat{r}_i$  ( $i = 0, 1, \dots, l$ ) and defining relations (11) with  $r_i$  replaced by  $\hat{r}_i$ . Denote by  $\varphi$  the homomorphism of  $\hat{W}$  onto  $W_\tau$  sending  $\hat{r}_i$  in  $r_i$ . Consider an auxiliary topological space  $X = (\hat{W} \times \bar{D}_0)/S$ , where  $\hat{W}$  is assumed to be endowed with the discrete topology and  $S$  is the equivalence relation defined by the formula

$$(w, x) \stackrel{S}{\sim} (w\hat{r}_i, x) \quad \text{if} \quad r_i(x) = x$$

extended via transitivity. Determine the  $\hat{W}$ -action on  $X$  by setting

$$w_1(w, x) = (w_1 w, x)$$

and the map  $\pi: X \rightarrow \mathfrak{a}(\mathbb{R})$  by setting

$$\pi((w, x)) = \varphi(w)x.$$

Finally, let  $Y$  be the set of points of  $\mathfrak{a}(\mathbb{R})$  that belong to the intersections of no more than two hyperplanes  $P_\xi$  and set  $X_0 = \pi^{-1}(Y)$ .

- 4) The space  $X_0$  is pathwise connected and the map  $\pi: X_0 \rightarrow Y$  is a covering.
- 5) The map  $\pi$  is a homeomorphism and  $\varphi$  is a group isomorphism. The relations (11) are defining relations for  $W_\tau$ .

- 6) The vertices of  $\bar{D}_0$  are the points  $\hat{t}\left(\frac{1}{kn_\alpha}x_\alpha\right)$  ( $\alpha \in \Pi_0$ ), where  $\{x_\alpha\}_{\alpha \in \Pi_0}$  is the basis of the lattice  $t_\tau(\mathbb{Z})$  dual to  $\Pi_0$  and  $n_\alpha$  is the same as  $n_i$  (see (5)).
- 7) The group  $\tilde{\Omega}_\tau$  coincides with the subgroup of motions  $w \in I(\tilde{t}(\mathbb{R}))$  such that  ${}^w(\Delta^\tau) = \Delta^\tau$ .
- 8) Let  $A \subset t_\tau(\mathbb{R})$  be the lattice consisting of  $v \in t_\tau(\mathbb{R})$  such that  $\alpha(v) \in \frac{1}{k_\alpha}\mathbb{Z}$  for all  $\alpha \in \Pi_0$  (see Problem 54). Let us identify  $A$  with the group of translations  $t_v$  ( $v \in A$ ) of  $\tilde{t}(\mathbb{R})$ . Then  $A$  is a normal subgroup of  $\tilde{\Omega}_\tau$  and  $\tilde{\Omega}_\tau = A \rtimes \Omega_0$ , where  $\Omega_0$  is the stabilizer of 0 in  $\tilde{\Omega}_\tau$ , isomorphic to the group of orthogonal transformations of  $t_\tau(\mathbb{R})$  induced by the automorphisms of  $\mathfrak{g}$  commuting with  $\hat{t}$ .
- 9) We have  $W_\tau = A_0 \rtimes W(\mathfrak{g}^{\hat{t}})$ , where  $A_0 \subset A$  is the sublattice with the basis  $\left\{\frac{1}{k_\alpha}h_{(\alpha,0)}: \alpha \in \Pi_0\right\}$ .
- 10) The elements  $e_{\gamma_i}$  ( $i = 0, 1, \dots, l$ ) generate the algebra  $\mathfrak{g}$ .
- 11) Let  $\theta$  be a unitary canonical automorphism of  $\mathfrak{g}$ , and  $u_0, u_1, \dots, u_l$  the corresponding numerical labels of the Kac diagram. Denote by  $\text{ad}_s$  the adjoint representation of  $\mathfrak{g}^\theta$  in the eigenspace  $\mathfrak{g}(e^{2\pi is})$  of  $\theta$ . Any  $\alpha_j \in \Psi$  is a lowest weight of  $\text{ad}_{u_j}$ . If  $s_0$  is the minimal of  $s > 0$  such that  $\mathfrak{g}(e^{2\pi is}) \neq 0$  then  $s_0$  coincides with one of the  $u_j$ , the lowest weights of  $\text{ad}_{s_0}$  are the  $\alpha_j$  such that  $u_j = s_0$  and the lowest vectors are the  $e_{\gamma_j}$ .

In Exercises 12–16 we assume that  $\tau = \text{id}$ . In this case  $t_\tau(\mathbb{R})$  coincides with the Euclidean vector space  $\mathfrak{h}(\mathbb{R})$  considered as an affine space. The normalizer of  $\tilde{W} = W_{\text{id}}$  in  $I(\mathfrak{h}(\mathbb{R}))$  is denoted by  $N(\tilde{W})$ . The lattices in  $\mathfrak{h}(\mathbb{R})$  are identified with the corresponding groups of translations.

- 12)  $\tilde{W} = W \times Q^\vee$ ,  $N(\tilde{W}) = \text{Aut } \Delta_{\mathfrak{g}} \rtimes \mathfrak{p}^\vee = \tilde{\Omega}_{\text{id}}$ .
- 13)  $N(\tilde{W}) = \text{Aut } \tilde{\Pi} \rtimes \tilde{W}$ .
- 14) The group  $\text{Aut } \tilde{\Pi}$  coincides with the group of motions of  $\mathfrak{h}(\mathbb{R})$  transforming  $\bar{D}_0$  into itself.
- 15)  $\text{Aut } \tilde{\Pi} = \text{Aut } \Pi \rtimes L$ , where  $L$  is a commutative normal subgroup isomorphic to  $\pi(\Delta_{\mathfrak{g}}) \simeq \pi_1(\text{Int } \mathfrak{g})$ .
- 16) The group  $\pi(\Delta_{\mathfrak{g}})$  acts simply transitively on the set  $\{\alpha_i \in \tilde{\Pi}: n_i = 1\}$ . In particular, the number of elements of this set equals  $|\pi(\Delta_{\mathfrak{g}})|$ .

### Hints to Problems

1. It suffices to prove that  $\text{Ker } \eta \subset H$ . If  $\theta \in \text{Ker } \eta$ , then  $\theta|_{\mathfrak{h}} = e$ ,  $\theta e_\alpha = c_\alpha e_\alpha$ ,  $\theta e_{-\alpha} = c_\alpha^{-1} e_{-\alpha}$  ( $\alpha \in \Pi$ ), where  $c_\alpha \in \mathbb{C}^*$ . With the help of Theorem 3.1 verify that  $\theta = \exp(\text{ad } x)$ , where  $x \in \mathfrak{h}$  is an element such that  $\alpha(x) = \log c_\alpha$  ( $\alpha \in \Pi$ ).
2. Make use of the fact that  $\text{Int } \mathfrak{g}$  acts transitively on the set of pairs  $\mathfrak{h} \subset \mathfrak{b}$ , where  $\mathfrak{h}$  is a maximal diagonalizable subalgebra and  $\mathfrak{b}$  a Borel subalgebra of  $\mathfrak{g}$ .
3. If  $(\text{Aut } \mathfrak{g})^0 \neq \text{Int } \mathfrak{g}$  then the algebraic group  $(\text{Aut } \mathfrak{g})^0$  is reducible since by Theorem 1 it is the union of a finite number of disjoint algebraic varieties: cosets modulo  $\text{Int } \mathfrak{g}$ . Concerning the last statement see 1.2.10°.

5. Make use of Problem 1.6.
6. If  $x \in \mathfrak{g}$  is nilpotent and  $z \in \mathfrak{z}(x)$  then  $(\text{ad } x)(\text{ad } z)$  is nilpotent implying  $(x, z) = 0$ . The invariance and non-degeneracy of the scalar product imply that  $\mathfrak{z}(x)^\perp = \text{Im}(\text{ad } x)$  so that  $x \in \text{Im}(\text{ad } x)$ .
7. If  $x \in \mathfrak{g}(\lambda)$  is nilpotent then by Problem 6  $x = [x, y]$ , where  $y \in \mathfrak{g}$ . Taking Problem 4 into account we may assume that  $y \in \mathfrak{g}(1)$ . If  $x \neq 0$  then  $y \neq 0$ .
9. For a given integer  $i$ ,  $0 \leq i < m$ , select a positive integer  $r$  such that  $k(r-1) < m-i \leq kr$ . Then  $kr+i = m+t$ , where  $0 \leq t < k$ , implying  $(\text{ad } x)^r | \mathfrak{g}(\varepsilon^i) = 0$ .
10. Make use of Theorem 1.1 and Problem 5. To prove the algebraicity note that  $\text{ad}(\mathfrak{g}^\theta)$  is the tangent algebra of the algebraic subgroup  $\{g \in \text{Int } \mathfrak{g} : g\theta = \theta g\}$ .
11. Since  $\mathfrak{z}(t)$  is reductive (see Problem 1.28), it suffices to prove that  $\mathfrak{z}(t)' = 0$ . Notice that  $\theta(\mathfrak{z}(t)') = \mathfrak{z}(t)'$  and apply Theorem 2 and the equality  $\mathfrak{z}(t)^\theta = t$ .
12. If  $t$  consists of singular elements then  $t \subset \text{Ker } \alpha$  for some root  $\alpha \in \Delta(\mathfrak{h}_1)$  contradicting Problem 11. Take for  $\Pi_1$  the system of simple roots corresponding to a Weyl chamber in  $\mathfrak{h}_1$  intersecting with  $t$ .
13. Take for  $a$  an automorphism sending  $\mathfrak{h}$  into  $\mathfrak{h}_1$  and transforming the Weyl chambers corresponding to  $\Pi$  and  $\Pi_1$  one onto another (see Theorem 2.7).
14. Make use of the fact that  $q: h \mapsto \hat{\tau}^{-1}h\hat{\tau}h^{-1}$  is an endomorphism of the torus  $H$  and  $d_e q = {}^t\tau - e$ .
15. Let  $\theta = \hat{\tau}h$ , where  $h \in H$ . Applying Problem 14 and expressing  $h$  in the form  $h = t\hat{\tau}^{-1}h_1\hat{\tau}h_1^{-1} = \hat{\tau}^{-1}h_1\hat{\tau}th_1^{-1}$ , where  $t \in T_\tau$ ,  $h_1 \in H$ , we see that  $h_1^{-1}\theta h_1 \in \hat{\tau}T_\tau$ .
17. Under the isomorphisms  $\mathfrak{h}(\mathbb{R})^* \rightarrow \mathfrak{h}(\mathbb{R})$  and  $\mathfrak{t}_\tau(\mathbb{R})^* \rightarrow \mathfrak{t}_\tau(\mathbb{R})$  associated with the Cartan scalar product (see 1.4°) the automorphism  $\tau: \mathfrak{h}(\mathbb{R})^* \rightarrow \mathfrak{h}(\mathbb{R})^*$  is identified with  $\hat{\tau} = {}^t\tau^{-1}$  and  $r$  with the averaging operator  $\pi = \frac{1}{k} \sum_{0 \leq j \leq k-1} \hat{\tau}^j$ , where  $k$  is the order of  $\tau$ . Clearly, the different elements  $\pi(u_\beta)$  ( $\beta \in \Pi$ ) form a basis of  $\mathfrak{t}_\tau(\mathbb{R})$ . This implies the statements on  $\dim \mathfrak{t}_\tau$  and  $r(\Pi)$ . Since each  $\gamma \in \Delta_\mathfrak{g}$  is expressed in terms of  $\Pi$  with the coefficients of the same sign,  $r(\gamma)$  is expressed in terms of  $\Pi_0$  with the coefficients of the same sign. In particular,  $r(\gamma) \neq 0$  for all  $\gamma \in \Delta_\mathfrak{g}$ . Therefore  $\mathfrak{z}(\mathfrak{t}_\tau) = \mathfrak{h}$  and  $\mathfrak{z}(\mathfrak{t}_\tau) \cap \mathfrak{g}^\theta = \mathfrak{t}_\tau$  for any  $\theta \in \hat{\tau}H$ .
18. Make use of the conjugacy of the maximal diagonalizable subalgebras of  $\mathfrak{g}^{\theta^2}$ .
23. Follows from the fact that  $\Delta(\mathfrak{t}_\tau)$  generates  $\mathfrak{t}_\tau(\mathbb{R})^*$  (see 1.4°) and that  $(0, 1) \in \Delta^\tau$ .
26. Similar to Problems 1.27 and 1.30.
27. Similar to Problem 1.42.
28. Similar to the proof of Theorem 1.6.
29. Similar to Problems 1.43 and 1.44.
30. The description of the root system  $\Delta_{\mathfrak{g}^{\hat{\tau}}}$  given in the problem follows from (2). To prove that  $\Pi_0$  is a system of simple roots for  $\mathfrak{g}^{\hat{\tau}}$ , it suffices (thanks to Problem 17) to verify that  $\Pi_0 \subset \Delta_{\mathfrak{g}^{\hat{\tau}}}$ . But if  $\beta \in \Pi$  then  $x = \sum_{0 \leq j \leq k-1} e_{\tau^j\beta} \neq 0$  and  $x \in \mathfrak{g}^{(r(\beta), 0)}$  implying  $r(\beta) \in \Delta_{\mathfrak{g}^{\hat{\tau}}}$ . If  $z \in \mathfrak{z}(\mathfrak{g}^{\hat{\tau}})$  then by Problem 17  $z \in \mathfrak{h}$ , and  $[z, x] = 0$  implies  $\beta(z) = 0$  for all  $\beta \in \Pi$ , i.e.  $z = 0$ .
31. Let  $x_0$  be a lowest vector of the representation  $\text{ad}_\mathfrak{g}$  corresponding to the weight 0. Then  $[e_\alpha, x_0] = 0$  for all  $\alpha \in \Delta_{\mathfrak{g}^{\hat{\tau}}}^+$ . Indeed, if this is not so then the system of weights of the representation of the three-dimensional subalgebra  $\langle h_\alpha, e_\alpha, e_{-\alpha} \rangle$  in the invariant subspace spanned by the vectors  $(\text{ad } e_\alpha)^m x_0$  (see

- 3.2°) is not symmetric. Therefore  $x_0$  belongs to the centralizer of  $\mathfrak{g}^{\hat{\tau}}$  contradicting Problem 30.
34. Use the invariance of the Cartan scalar product with respect to all automorphisms.
  36. Similar to Problem 1.37.
  37. Verify that  $\hat{\tau}\varphi_{\xi}(x)\tau^{-1} = \varphi_{\xi}(cxc^{-1})$  for all  $x \in \mathfrak{sl}_2(\mathbb{C})$ , where  $c = \text{diag}(e^{\pi is}, e^{-\pi is})$ . This implies that  $\hat{\tau}\Phi_{\xi}(g)\hat{\tau}^{-1} = \Phi_{\xi}(cgc^{-1})$  for all  $g \in \text{SL}_2(\mathbb{C})$ . Setting  $g = \begin{pmatrix} 0 & 1 \\ -1 & 0 \end{pmatrix}$  we get (3). Since  $r_{\alpha}$  is the linear part of the affine transformation  $r_{\xi}$ , (3) implies, by Problems 22 and 36, that  $\pi(r_{\xi}(y)) = n_{\xi}\pi(y)n_{\xi}^{-1}$  for  $y \in \mathfrak{a}(\mathbb{R})$ .
  38. Similar to Problems 2.18 and 2.19.
  39. Use Theorems 5 and 6.
  40. To prove that  $D_0$  is a chamber make use of Problem 33. The formula (4) is proved similarly to the corresponding statement of Problem 2.18.
  43. Make use of the inclusion  $Q^{\vee} \subset \tilde{W}$  and Theorem 6.
  44. Identifying  $r$  with the projection  $\pi: \mathfrak{h}(\mathbb{R}) \rightarrow \mathfrak{t}_{\tau}(\mathbb{R})$  (see Hint to Problem 17) it is easy to show that  $(r(\alpha), r(\beta)) = 0$  for  $\alpha, \beta \in \Pi$  if and only if the orbits of  $\alpha$  and  $\beta$  are orthogonal to each other. By Theorem 2.2 this implies the statement of the problem.
  46. By Problem 45,  $\mathfrak{g}(\varepsilon) \neq 0$ . If  $\alpha_0$  is a lowest weight of the representation  $\text{ad}_{1/k}$  then  $\gamma_0 = (\alpha_0, 1/k) \in \Pi^{\tau}$  (Problem 32). Since  $\Pi_0$  is indecomposable and  $\alpha_0 \neq 0$ , we see that  $\Psi' = \{\alpha_0, \alpha_1, \dots, \alpha_l\}$  is indecomposable. By Problem 2.45 the indecomposable component of  $\Psi$  containing  $\Psi'$  coincides with  $\Psi'$  implying  $\Psi = \Psi'$ . The linear independence of  $\Pi^{\tau}$  follows from Problem 33 and from the equality  $\dim \mathfrak{a}(\mathbb{R})^{\wedge} = l + 1$ .
  47. Problem 17 implies validity of the expression (12), where  $n_j \in \mathbb{Z}$ . Since  $\Psi$  is indecomposable, Problem 2.45 implies that  $n_j > 0$  for all  $j$ .
  48. The admissibility of  $\Psi$  follows from Problem 27.
  50. Problem 2.18 implies that the  $P_{\gamma_j}$  ( $j = 1, \dots, l$ ) are the walls of the chamber  $D_0$ . Formula (5) implies that  $C_0 \cap P_{\gamma_0} \neq \emptyset$ . Therefore  $\mathfrak{p}_{\gamma_0}$  is also a wall of this chamber.
  52. By Problem 5 there exists  $w \in \tilde{\Omega}_{\tau}$  such that  $w(\text{Re } y_1) = \text{Re } y_2$  and  $w(D_0) = D_0$ . Applying Problems 46 and 28 we see that  $w$  determines an automorphism of the Dynkin diagram of  $\Psi$  which is an isomorphism of our Kac diagrams.
  53. Notice that  $\zeta(\Pi_0) \subset \Delta_{\mathfrak{g}^{\hat{\tau}}}$ . In case  $\tau = \text{id}$  this is obvious since  $\Psi = \tilde{\Pi}$  (Problem 46). If  $\tau \neq \text{id}$  then  $\zeta = \text{id}$  except for the cases when  $\Psi$  is of the type  $A_{2l-1}^{(2)}$  or  $D_{l+1}^{(2)}$  (see Table 6). In the latter two cases the only nontrivial automorphism  $\zeta$  is the transposition of  $\alpha_0$  with one of the roots  $\alpha_i \in \Pi_0$ . As is clear from Example 4 in 2.5°, we have  $\alpha_0 \in \Delta_{\mathfrak{g}^{\hat{\tau}}}$ . Theorem 2.9 implies that  $\zeta \in \text{Aut } \Delta_{\mathfrak{g}^{\hat{\tau}}}$  and  $\zeta(\Pi_0)$  is a base of  $\Delta_{\mathfrak{g}^{\hat{\tau}}}$ . Applying Theorem 3.1 we get an automorphism  $\mu \in \text{Aut}(\mathfrak{g}^{\hat{\tau}})$  transforming  $\mathfrak{t}_{\tau}$  into itself and such that  ${}^t\mu = \zeta$  on  $\mathfrak{t}_{\tau}^*$ . In case  $\tau = \text{id}$  the desired automorphism is  $\mu$ . If  $\tau \neq \text{id}$  and  $\zeta \neq \text{id}$  then  $\mathfrak{g}^{\hat{\tau}}$  is of the type  $B_l$  or  $C_l$  (see Table 7). By Theorem 1 all automorphisms of  $\mathfrak{g}^{\hat{\tau}}$  are inner ones so that  $\mu$  extends to an automorphism of  $\mathfrak{g}$  commuting with  $\hat{\tau}$ .
  54. We have  $\mathfrak{h}(\mathbb{Z}) = Q^*$ , where  $Q$  is the root lattice in  $\mathfrak{h}(\mathbb{R})^*$ . If  $\{z_{\beta}: \beta \in \Pi\}$  is a

- basis of  $\mathfrak{h}(\mathbb{Z})$  dual to  $\Pi$  then the elements  $x_\alpha = \sum_{r(\beta)=\alpha} z_\beta$  ( $\alpha \in \Pi_0$ ) form a basis of the lattice  $t_\tau(\mathbb{Z})$  dual to  $\Pi_0$ . It is directly verified that  $x_\alpha/k_\alpha - z_\beta \in t_\tau^\perp$  if  $\alpha = r(\beta)$ . For each  $\alpha \in \Pi_0$  choose  $\beta \in \Pi$  such that  $r(\beta) = \alpha$ . If  $v \in t_\tau(\mathbb{R})$  satisfies the conditions of the problem it presents in the form  $v = \sum_{\alpha \in \Pi_0} l_\alpha(k_\alpha)^{-1} x_\alpha$ , where  $l_\alpha \in \mathbb{Z}$ , implying  $v - \sum_{\alpha \in \Pi_0} l_\alpha z_\beta \in t_\tau^\perp$ .
55. Problems 54 and 14 imply that  $v = {}^t_\tau x - x + z$ , where  $x \in \mathfrak{h}$ ,  $z \in \mathfrak{h}(\mathbb{Z})$ . If  $\tilde{h} = \mathcal{E}(x) \in H$  then  $h\hat{t}h^{-1} = \hat{t}\mathcal{E}(v)$ , so that  $h \in N_\tau$ . It is easy to verify that  $\omega(h) = y t_v$ .
56. Let  $s \in O(t_\tau(\mathbb{R}))$  be the linear part of  $w$ . Then  $t_s \in \text{Aut } \mathcal{P}$ . By Problem 53  $s$  extends to an automorphism (denoted by the same letter) belonging to  $N_\tau$  and commuting with  $\hat{t}$ . Express  $w$  in the form  $w = t_v \sigma$ , where  $\sigma(\tilde{a}) = \tilde{a}$  and  $t_v(\tilde{a}) = w(\tilde{a})$ . Clearly,  $\sigma$  covers the transformation  $w(s)$  so that  $\sigma \in \tilde{\Omega}_\tau$ . To show that  $t_v \in \tilde{\Omega}_\tau$  it suffices to verify that  $v$  satisfies the conditions of Problem 55. We may assume that  $v \neq 0$ . Then  ${}^t_w(\gamma_j) = \gamma_0$  for some  $j > 0$ . We deduce from this that  $\alpha_j(v) = 1/k$ ,  $\alpha_i(v) = 0$  for  $i \neq j$ . If  $k = 1$  then the needed conditions are clearly satisfied. If  $k > 1$  then  $k = 2$  (see Hint to Problem 53). Since  $s'\alpha_j = \alpha_0$  and since  $s$  commutes with  $\hat{t}$ , we have  $\mathfrak{g}_{\alpha_j} \cap \mathfrak{g}(-1) = s(\mathfrak{g}^{\gamma_0}) \neq 0$ . Therefore  $(\alpha_j, 1/2) \in \Delta^\tau$  implying  $k_{\alpha_j} = 2$ , and  $v$  satisfies the desired conditions.
57. Apply the following statement, which is a consequence of Problem 2: if  $\xi \in \Delta^\tau$  and  $\xi = \sum_{0 \leq j \leq l} k_j \gamma_j$ , where  $k_j \in \mathbb{Z}$  then  $\theta|_{\mathfrak{g}^\xi} = c \cdot \text{id}$ , where  $c = e^{2\pi i \sum_{0 \leq j \leq l} k_j \gamma_j}$ . Formula (9) follows from (7).
58. Show that the tangent algebra of the subgroup  $Z(\mathcal{E}(x))$  coincides with  $\mathfrak{h} \oplus \bigoplus_{\alpha(x) \in \mathbb{Z}} \mathfrak{g}_\alpha$ .
59. Deduce from Problem 1.28 and the fact that  $\text{Ad } g$  is a semisimple automorphism of the Lie algebra  $\mathfrak{g}$  that  $H$  is reductive. Let  $H = VZ_H$ , where  $V$  is a connected semisimple normal subgroup and  $Z_H$  the identity component of the center of  $H$ . Then  $S \subset Z_H$ . Clearly,  $\Theta(V) = V$ . If  $\dim V > 0$  then  $\dim V^\theta > 0$  (Theorem 2) contradicting the maximality of the torus  $S$  in  $U^\theta$ . Therefore  $H = Z_H$  is a torus. Making use of Problem 3.3.26 we see that  $g \in H$  and  $H$  is a maximal torus.
60. See hint to Problem 58.
61. By Problem 10  $\mathfrak{g}^\theta$  is a reductive algebraic subalgebra and by Problem 17  $t_\tau$  is its maximal diagonalizable subalgebra. If  $\theta = \pi(u)$ , where  $u \in \bar{D}_0$ , then  $\mathfrak{g}^\theta = t_\tau \oplus \sum_{\xi(u) \in \mathbb{Z}} \mathfrak{g}^\xi = t_\tau \oplus \sum_{\xi \in \Delta_1} \mathfrak{g}^\xi$ , where  $\Delta_1 = \{\xi \in \Delta^\tau: \xi(u) = 0\}$ . It is clear from (9) that  $\Delta_1$  consists of the roots expressed in terms of  $\gamma_{i_1}, \dots, \gamma_{i_t}$  only. By (8)  $t \leq l$ , hence  $\{\alpha_{i_1}, \dots, \alpha_{i_t}\}$  is a linearly independent system. This implies that the linear parts of roots from  $\Delta_1$  constitute the root system for  $\mathfrak{g}^\theta$  and  $\{\alpha_{i_1}, \dots, \alpha_{i_t}\}$  is its base.